

O‘ZBEKISTON RESPUBLIKASI QURILISH VAZIRLIGI

TOSHKENT ARXITEKTURA QURILISH INSTITUTI

**CHIZMA GEOMETRIYA VA MUHANDISLIK
GRAFIKASI**

fanidan sirtqi ta’lim uchun metodik qo‘llanma

Toshkent 2018 y.

“Chizma geometriya va muhandislik grafikasi” fanidan sirtqi ta’lim uchun metodik qollanma S.S.Saydaliyev -Toshkent, TAQI, 2018, 103 b.

“Chizma geometriya va muhandislik grafikasi” fanidan sirtqi ta’lim uchun yozilgan metodik qo’llanma hozir amal qilinayotgan namunaviy dastur asosida yozilgan. Qo’llanmada mualliflarning TAQIda “Chizma geometriya va muhandislik grafikasi” fanidan bugungi kunda yangi adabiyot yaratishga qo’yilgan talablar hamda xorij adabiyotlaridagi ma’lumotlar asos ishlab chiqilgan.

Ushbu qo’llanma Toshkent arxitektura qurilish institutidagi 5340200 Bino va inshootlar qurilishi, 5340300 Shaxar qurilishi va xo’jaligi, 5340400 Muhandislik kommunikatsiyalarini qurilishi va montaji, 5340500 Qurilish materiallari, buyumlari va konstruksiyalarni ishlab chiqarish, 5340700 Gidrotexnika qurilishi, 5340900 Ko‘chmas mulk ekspertizasi va uni boshqarish, 5341101 Qiymat injiniringi bakalavriyat yo‘nalishidagi sirtqi talabalar uchun mo‘ljallangan.

Toshkent temir yol muhandislar instituti “Chizma geometriya va muhandislik grafikasi” fanidan kasbiy qayta tayyorlanuvchi tinglovchilari, oliy texnika o‘quv yurtlarining magister va bakalavr talabalari, injiner, texnik xodimlar foydalanishi mumkun.

Taqrizchilar: Toshkent arxetektura va qurilish institutining “Chizma geometriya va kompyuterda loyihalash” kafedrasida katta o‘qituvchi B.Nig‘monov,

Toshkent temir yol muhandislar institute “Informatika va kompyuter grafikasi” kafedrasida katta o‘qituvchi A.E.Jabborov.

Mazkur o‘quv qollanma Toshkent arxetektura va qurilish institutining 2018 yil _____gi kengashida №___ bayonnoma bilan tasdiqlandi.

KIRISH

Chizma geometriya va muhandislik grafikasi fanidan chizmalarni tuzish va o'qishga imkon beradigan bilim va malakalar orttirish, shuningdek, fazoviy tasavvurni rivojlantirish uchun zarurdir. Chizmalarni tuzish va o'qish, tasvirlar yasash metodini, turli pozitsion va metrik masalalar yechishni va chizma geometriya hamda qurilish chizmachilikda qabul qilingan bir qator shartliliklarni bilishga asoslanadi. Fazoviy tasavvur deganda insonning ayrim qismlar shakli, o'lchamlari, proporiyasini, rangni, sirt fakturasini va turli buyumlarning, jumladan, bino, inshoot va konstruksiyaniing ayrim sifatlarini fikran ko'z oldiga keltirish xususiyati tushuniladi.

Proeksiyalash metodi deb ataladigan tasvirlar yasash metodi chizma geometriya va muhandislik grafikasi uchun umumiydir. Chizma geometriyada bu metodning nazariy asoslari o'rganilsa, muhandislik grafikasida amalda qo'llanilishi o'rganiladi. «Chizma geometriya va muhandislik grafikasi» kursida chizmalar yasash va ularni bajarish yo'llarining chizma geometriyada foydalaniladigan qoidalari o'rganiladi. Qurilish chizmachilikdan olingan malakalar muhandislik grafikasida va chizma geometriyada qo'llaniladi. Shuning uchun chizma geometriya va muhandislik grafikasi bir vaqtning o'zida o'rganiladi.

Sirtidan o'quvchi talabaning asosiy ish uslubi materialni darslikdan, o'quv qo'llanmalaridan, shuningdek, KXYaTning tegishli GOSTlaridan foydalanib mustaqil o'rganishdir (KXYaT — Konstruktorlik hujjatlarining yagona sistemasi Davlat standartlari 1971 yilning 1 yanvardan joriy qilingan va 2006 yil yangilanib O'zDTS deb yuritiladi).

Grafik ishlar. Talabalar grafik ishlarning grafikaviy qismini tegishli A3 yoki A1 formatli chizmachilik qog'oziga bajaradilar. Grafik topshiriqlarning hamma chizmalarida o'ng tomondagi pastki burchakka asosiy yozuv (1-chizma) joylashtiriladi. Unda chizmaning nomi, institut, studeitning familiyasi va ismi, uning shifri (talabalik bileti nomerining oxirgi ikki raqami) ko'rsatilishi kerak.

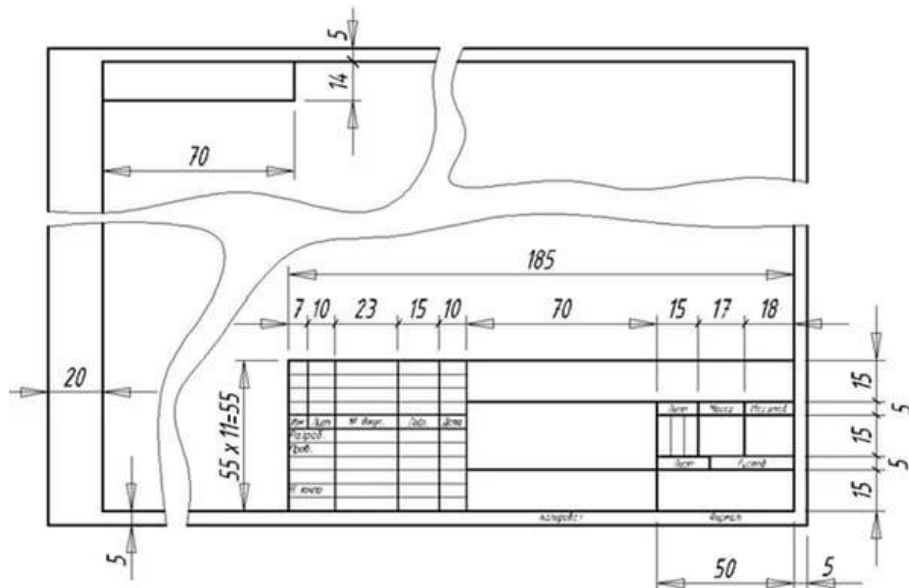

1-shakl

Mashinasozlik detallarining eskizlarida va ish chizmalarida asosiy yozuv, KXYoTning standartlariga muvofiq bajariladi.

Topshiriq varianti sinf jurnalida ro'yhatga olingan talaba raqamiga to'g'ri kelishi kerak. Masalan, talabaning raqami (1-Abdullaev A.) bo'lsa, u 1-variantni bajaradi.

Bajarilgan grafik ishlarning varaqlari 12(297X210) yoki 24(841X594) formatgacha taxlanadi va institutga taqriz uchun yuboriladi yoki kafedraning o'quv-konsultatsion bo'limga topshiriladi.

Chizma geometriyadan grafik ishga tushuntirish xati ilova qilinadi. Tushuntirish xatida chizmada bajarilgan barcha yasashlar qisqacha asoslangan bo'lishi zarur. Shundagina o'qituvchi talabaning ayni temaga oid nazariy masalalarni qanchalik birlashtirishi, o'z fikrini qanchalik aniq ifodalash va atamalarni qanchalik to'g'ri ishlatganligi haqida biror xulosaga keladi.

Kafedraga yuboriladigan grafik ishda shu ishga oid hamma masalalar yechilgan bo'lishi kerak. Aks holda grafik ish ko'rib chiqilmay talabaga qaytariladi.

Har bir grafik ishga o'qituvchi baxolaydi, bunda ishning afzallik va kamchiliklari qisqacha ko'rsatiladi. Grafik ish baxosi bilan birga sirtidan o'quvchi talabaga qaytariladi. Chizmaga yoki mustaqil ta'limga o'qituvchi qo'ygan belgilarni o'chirish yaramaydi. Agar ishga zaryot qo'yilmagan bo'lsa, o'qituvchi o'z grafik ishning qaysi qismini qayta ishlash yoki grafik ishning hammasini yangidan bajarish kerakligini ko'rsatadi. Takroriy grafik ishning hammasini, shu jumladan, maruzachi qabul qilgan masalalarni ham yuborish kerak. Navbatdagi grafik ishni bundan oldingisining javobini kutmayoq bajarishga kirishish lozim.

Mustaqil ta'lim. Mustaqil ta'limda talabalarga mustaqil ish daftari beriladi. Bu ishchi daftarda chizma geometriya va muhandislik grafikasi fanidan o'quv reja asosida ishlab chiqilgan namunaviy dastur va ishchi dasturdagi mustaqil ta'lim uchun ajratilgan saotlardan kelib chiqqan holda uning mavzulariga oid metrik va pozitsion masalalar berilgan, shu masalalarni chizma geometriya fani darsliklaridan foydalanib ishlab chiqiladi. Bundan tashqari mustaqil ish daftari ichida grafik ishlarning namunalari, varyatlari keltirilgan.

Konsultatsiyalar. Institut yoki kafedraga shaharda yashovchi studentlar uchun o'quv mashg'ulotlarining barcha turlari: mazruzalar, konsultatsiyalar, amaliy mashg'ulotlar tashkil qilinishi mumkin. Qolgan studentlar uchun o'qituvchilar laboratoriya-imtihon sessiyasi davrida maruzalar o'qiydi va konsultatsiyalar beradi. Kursni o'rganishda savollar tug'ilishi mumkin. Bunday holda tushunib olish uchun institutning chizma geometriya va kompyuterda loyihalash kafedrasiga o'g'zaki yoki yozma ravishda murojaat qilish lozim.

Imtihonlar. Chizma geometriyadan imtihon o'tkaziladi. Imtihondan oldin talaba baxo qo'yilgan barcha grafik ishlarni va mustaqil ish daftarini topshiradi va o'qituvchining grafik ishlarni bajarishga oid savollariga javob qaytaradi. Chizma geometriya va muhandislik grafikasi fanidan xuddi shu tartibda zaryot topshiriladi. Zaryotga ishchi dasturda ko'zda tutilgan barcha grafik

ishlarni bajargan talabalargina qo'yiladi. Imtihonda talaba ikki-uch masalani yechgani va shtixon biletida ko'rsatilgan nazariy savollarga javob qaytarishi zarur. Bundan tashqari, imtnhon olvchiga qo'shimcha savollar berish huquqi beriladi. Imtihonni, odatda, kafedraning professori yoki dotsenti qabul qiladi.

SIRTQI TA'LIM DASTURI

1. O'quv fani o'qitilishi bo'yicha uslubiy ko'rsatmalar.

“Chizma geometriya va injenerlik grafikasi” fani oliy professional bilim darajasini belgilovchi Davlat talim standartida umum talim va umumprofessional o'quv fanlari qatoridan o'rin olgan.

«Chizma geometriya va injenerlik grafikasi» ni talabalarga o'qitishdan asosiy maqsad turli ob'ektlar va ulardagi bog'liqliklarni, chizmalar ko'rinishidagi fazoviy shakllari va munosabatlarini fazoviy va xayoliy tasavvur qilish, fazoviy konstruktiv-geometrik fikrlash, shuningdek, ularni fazoviy taxlil qilish va umumlashtirish, chizmalarni o'qish va yaratish, ishlab chiqarishning konstruktorlik va texnikaviy hujjatlarni tayyorlashga oid bilim, ko'nikma va malaka shakllantirishdir.

«Chizma geometriya va injenerlik grafikasi» ni o'rganishdagi asosiy vazifa fazoning markaziy va ortogonal proektsiyalashga asoslangan muayyan grafik modellarini xosil qilish usullarining ilmini mukammal egallash va bu grafik modellarda fazoviy shakllar, xamda ularning munosabatlariga oid masalalarni mustakil yecha oladigan darajaga erishish, chizmalar yaratishda standartlar va konstruktorlik hujjatlarga rioya qilishdan iborat.

«Chizma geometriya va injenerlik grafikasi» o'quv fanini o'zlashtirish jarayonida amalda oshiriladigan masalalar doirasida bakalavr:

- ortogonal va markaziy proektsiyalashlarga asoslangan chizma geometriya usullari; standartlash davlat tizimi, konstruktorlik xujjatlar majmuasi, standartlar, standart buyumlar va konstruktorlik xujjatlari turlari; muhandislik grafikasi qoidalari va usullari; ortogonal va aksonometrik proektsiyalarda soyalar, perspektiva yasash va perspektivada soyalar yasash usullari; qurilish chizmalar turlari va konstruksiyalari, texnik sxemalari, shartli belgilari; kompyuter grafik dasturlar imkoniyatlari; kompyuterda grafik tasvirlar yaratish *haqida tasavvurga ega bo'lishi;*

- proektsiyalash usullari va loyihalash asoslarini; geometrik modellashtirish usullarini; aksonometrik va perspektiv tasvirlashni; perspektiva qurish usullarini; ortogonal, aksonometrik proektsiyalar va perspektivada soyalarni qurish usullarini; texnik chizmalar va eskizlar o'qishni; turli qurilish chizmalarini o'qishni; konstruktorlik hujjatlarni; kompyuter yordamida ikki va uch o'lchamli tasvirlar chizmasini bajarishni *bilishi va ulardan foydalana olishi;*

- chizma geometriya va injenerlik grafikasi qoidalari, usul va yo'riqlarini qo'llash; proektsion chizmalar, perspektiva va soyalar yasash qonunlarini, usul va yo'riqlarini qo'llash texnik sxemalar va eskizlarni bajarish;- qurilish chizmalarini bajarish; kompyuterda chizmalar va loyixalar yaratish *ko'nikmalarga ega bo'lishi kerak.*

2. Ma'ruza mashg'uloti

1-jadval

N_o t\b	Mavzular	Soat
1-semestr		
1	Chizma geometriya va muhandislik grafikasi fani tarixi. Proeksiyalar metodi xaqida umumiy ma'lumotlar.	2
2	Qurilish chizmalari. Qurilish chizmalarining mazmuni. Qurilish chizmalarining nomi va markirovkasi. Ularning masshtablari va konstruksiyasi elementlari.	2
3	Qurilish chizmachiligi xaqida umumiy ma'lumotlar. Plan, fasad, qirqim.	2
2-semestr		
1	Perspektiva qurish apparati. To'g'ri chiziq, tekis shakl va geometrik jismlarning perspektivasi.	2
2	Perspektiva yasash usullari. Arxitektorlar usuli.	2
3	Bino perspektivasida soyalar yasash.	2

Jami **12 soat**

Ma'ruza mashg'ulotlari multimedia qurilmalari bilan jixozlangan auditoriyada akadem guruhlar oqimi uchun o'tiladi.

3. Amaliy mashg'ulotlar

2-jadval

N_o	Mavzular	Soat
1-semestr		
1	Chizma geometriya fani. Monj apparati. Nuqtaning koordinatalari bo'yicha oktanti va epyuri.	2
2	Ko'rinish. Qirqim. Aksonometrik proeksiya.	2
3	Bino qirqimi, zinani joylashtirish. Qurilish konstruksiyalarining chizmalari. Ularning turlari va shartli belgilari.	2
2-semestr		
1	Ortogonal proeksiyalarda soyalar yasash bo'yicha nuqta, to'g'ri chiziq va tekis shaklning o'z va tushuvchi soyalarini topish.	2
2	Sonlar bilan belgilangan proeksiyalar.	2
3	Er ishlari chegarasini aniqlash bo'yicha ma'lumotlar.	2

Jami **12 soat**

4. Mustaqil ta'lim

3-jadval

Mashg'ulotlar nomeri	Mashg'ulotning nomi va qisqacha mazmuni	Dars soatlari hajmi
1-semestr		
1	Nuqtalarning koordinatalari bo'yicha 8 oktantda epyurlarini yasash.	4
2	Standart shrifta titul varaq chizish	4

3	To'g'ri chiziqning fazodagi holati oid masalalar to'plamdan yechish.	4
4	Lekalo egri chiziqlar, tutashmalar, qiyalik, konuslik.	4
5	To'g'ri chiziqning izlari va ikki to'g'ri chiziqning o'zaro holatlari oid masalalar yechish	4
6	Tekislikdagi yetgan nuqta va to'g'ri chiziqlar oid masalalar yechish.	4
7	Tekisliklarning kesishuviga oid masalalar yechish. To'g'ri chiziq va tekislikning kesishuviga oid masalalar yechish.	4
8	Berilgan ikki proeksiyaga ko'ra detalning uchinchi proeksiyasini yasash.	4
9	To'g'ri chiziq va tekislikning perpendikulyarligi va ikki tekislikning o'zaro perpendikulyarligiga oid masalalar yechish.	4
10	Berilgan ikki proeksiyaga ko'ra detalning uchinchi proeksiyasi va aksonometrik proeksiyasini yasash. Kerakli qirqimlar berish.	4
11	Masalalar to'plamidan umumiy usullar asosida kompleks masalani yechish	4
12	Proeksiya tekisliklarini almashtirish usuliga oid masalalar yechish	4
13	Proeksiya tekisliklarini aylantirish usuliga va o'z izlaridan biri atrofida aylantirish (joylashtirish) usuliga oid masalalar yechish	4
15	Sirtlar. Ularning turlari. Ko'pyoqlar. Ko'pyoqlar kesishuvi.	4
16	Sirtlarning to'g'ri chiziq va proeksiyalovchi tekislik bilan kesishuvi.	4
17	Sirtlarning tekislik bilan kesishuvi. Kesim yuzasining haqiqiy kattaligi.Sirtning yoyilmasi.	4
18	Sirtlarning o'zaro kesishuvi va ularning yasash usullari. Yordamchi tekislik usuli.	4
19	Yordamchi sharlar usuli.	4
20	Qurilish chizmachiligi xaqida umumiy ma'lumotlar. Plan, fasad, qirqim.	2
2-semestr		
1	Sonlar bilan belgilangan proeksiyalar bo'limini darsliklardan o'rganish	4
2	Er ishlari chegarasini aniqlash bo'yicha ma'lumotlar olish.	4
3	Ortogonal proeksiyalarda soyalar yasash bo'yicha nuqta, to'g'ri chiziq va tekis shaklning o'z va tushuvchi soyalarini topish.	4
4	Geometrik jismlar soyasini yasash.	4
5	Geometrik jismlar guruxini aksonometriyada soyasini yasash.	4
6	Sodda shakllar perspektivasini yasash.	4
7	Arxitektorlar usulidan foydalanib, perspektiva apparati va sodda bino perspektivasini yasash	4

8	Sodda geometrik jismlarning perspektivada soyalarini yasash.	4
9	Qurilish chizmalariga oid ma'lumotlarni adabiyotlardan o'rganish.	4
10	Binoning qirqimi, qirqimdagi zina, fasadlar haqida adabiyotlarni o'rganish.	4
11	Temir beton, metall va yog'och konstruksiyalar chizmalaridagi shartli belgilarni adabiyotlarni o'rganish.	4
12	Birikmalar. Ajraladigan va ajralmaydigan birikmalar Rezbalar. Rezbalarni belgilash. Metrik rezbalar. Dyuum rezbalar.	4
13	Rezbali birikmalar, mahkamlash detallari. Spesifikatsiya.	4
14	Detalning ortogonal proeksiyalardagi soyalarini yasash.	4
15	Geometrik jismlar guruhining aksonometriyada soyasini yasash.	4
16	Aksonometrik proeksiyada soyalar.	4
17	Bino planida o'lcham qo'yish.	4
18	Eshik, deraza o'rinlari, qirqimda balandlik o'lchamlari, zinani ko'rsatish.	4
19	Bino qirqimi, zinani joylashtirish. Fasad, eshik va derazalar, o'lchamlar qo'yish.	4
20	Qurilish konstruksiyalarining chizmalari. Ularning turlari va shartli belgilari. Sanitar texnik uskunalarning chizmalari, shartli belgilari.	4

Jami

158 soat

Мустақил ўзлаштириладиган мавзулар бўйича талабалар томонидан мустақил иш дафтари топширилади.

Фан бўйича график иши. Чизма геометрия ва инженерлик графикаси фанидан график ишларнинг мазмуни ва ҳажми. Берилган шартга кўра график иш А3 ёки А1 форматда бажарилади. Талабалар график ишларини баҳолатиб борадилар. Семестр охирида албом шаклида топширилади. 1- семестрда талабаларнинг график ишлари 10 та, 2-семестрда талабаларнинг график ишлари 6 тани ташкил этади.

Т.р.	График ишларнинг мазмуни	Формат
	1-семестр	
1	Учбурчак ABC текисликнинг горизантал ва фронтал изларини аниқлансин.	A3
2	S нуқтадан ABC текисликгача бўлган масофа аниқлансин.	A3
3	Проекция текисликларини алмаштириш усулидан фойдаланиб ABC текисликни ҳақиқий катталигини аниқлаш.	A3
4	Берилган икки кўриниш бўйича учинчи кўринишини топинг ва керакли қирқимини бажаринг ҳамда аксонометриясини қуринг, зурурий қирқимини бажаринг.	A3
5-8	Бинонинг архитектура-қурилиш чизмаси: план, фасад, қирқим. А-бирикмасининг чизмаси.	A3x4 (A1)
9-10	Металл ва темир-бетон конструкция бирикмасининг иш	A3x2

	чизмаси ва аксонометрик проекцияси	
	2-семестр	
1	Архитекторлар усулида перспектива қуриш	А3
2	Топографик сиртга қурилиш иншооти планини лойиҳалаш. Вертикал қирқимини яшаш.	А3
3	Ортогонал проекцияда соялар яшаш	А3
4	Бино перспективасида соялар яшаш.	А3
5	Қурилиш конструкцияларининг чизмалари. Уларнинг турлари ва шартли белгилари.	А3
6	Санитар-техника ускуналарининг шартли белгилари.	А3

5. Фан бўйича талабалар билимини баҳолаш ва назорат қилиш меъзонлари.

Талабаларнинг рейтинг меъзони семестр давомида аниқланади ва қуйидаги тартибда баҳоланади:

"Чизма геометрия ва инженерлик графикаси" фанидан рейтинг ишланмаси ва баҳолаш меъзонлари

Рейтинг ишланмаси

Т.р.	Назорат турлари	Сони	Балл	Жами балл
1	ЖН 1.1.Таълимдаги мустақил ишларни (уй график ишлар) бажариш	10(n*)	4	40
2	МТ 2.1.Мустақил таълим (Иш дафтари)	1	20	20
3	ЯН 3.1. График иш бажариш (3 масала)	3	10	30
Жами				100

*Илова: n- уй график ишлар сони

Фойдаланиладиган адабиётлар рўйхати

Асосий адабиётлар

1. George Young. Descriptive geometry. The Macmillan Company, New York. 2013.
2. E. G. Pare, R. O. Loving, I. L. Hill, R. C. Pare. Descriptive geometry. Prentice Hall Upper Saddle River, New Jersey, 1997.
3. Engineering Drawing by M. B. Shah, B. C. Rana. D. Kindersley, Delhi, 2009.
4. Ш. Муродов, Л. Хақимов, А. Холмурзаев, М. Жумаев, А. Тўхтаев. Чизма геометрия, Иқтисод-молия, 2006.
5. Э. Финкелштейн, Л. Амбросиус. AutoCAD 15. Ж. Вилей & Сонс Инс. Индианаполис. 2014.

Қўшимча адабиётлар

1. Мирзиёев Ш. М. Танқидий таҳлил, қатъий тартиб-интизом ва шахсий жавобгарлик-ҳар бир раҳбар фаолиятининг кундалик қондиқаси бўлиши керак. Т., "Ўзбекистон". 2016й. 55 бет.

2. Мирзиёев Ш.М. Қонун устуворлиги ва инсон манфаатларини таъминлаш - юрт тараққиёти ва халқ фаровонлигининг гарофи. Т., “Ўзбекистон”. 2016й. 486 бет.
3. Мирзиёев Ш.М. Буюк келажакимизни мард ва олижаноб халқимиз билан бирга қураимиз. Т., “Ўзбекистон”. 2016й. 55 бет.
4. Р.Деракхшани. 3Ds Max 15. Сйбех-Ж.Вилей&Сонс Инс. Индианаполис. 2014
5. Хорунов Р.Х. Чизма геометрия курси. Тошкент. «Ўқитувчи», 1997.
6. С.С. Сайдалиев Чизма геометрия ва муҳандислик графикаси. ТАҚИ. 2017.
7. Л.Ў.Расул-Заде, Ж.Х.Мирхамидов. Чизма геометрия (Перспектива ва соялар). Тошкент. ТАҚИ, 2015.
8. Раҳмонов И, Абдурахмонов А. Чизмачилирдан маълумотнома. Ўзбекистон Миллий кутубхонаси нашриёти. Тошкент, 2005.

Интернет сайтлари

9. www.AutoCAD.ru.
10. www.Autodeks.com.

GRAFIK ISHLARGA OID KO'RSATMALAR VA NUMUNALAR (1-semestrda)

1-grafik ish.

**Uchburchak ABC tekislikning gorizantal va frontal izlarini aniqlansin
(Namuna).**

Tekislikning izlarini yasash uchun, shu tekislikda eng kamida ikkita yoki hamma tomonining (2-shakl, a) izlarini yasab ularni tutashtirishdan hosil qilinadi.

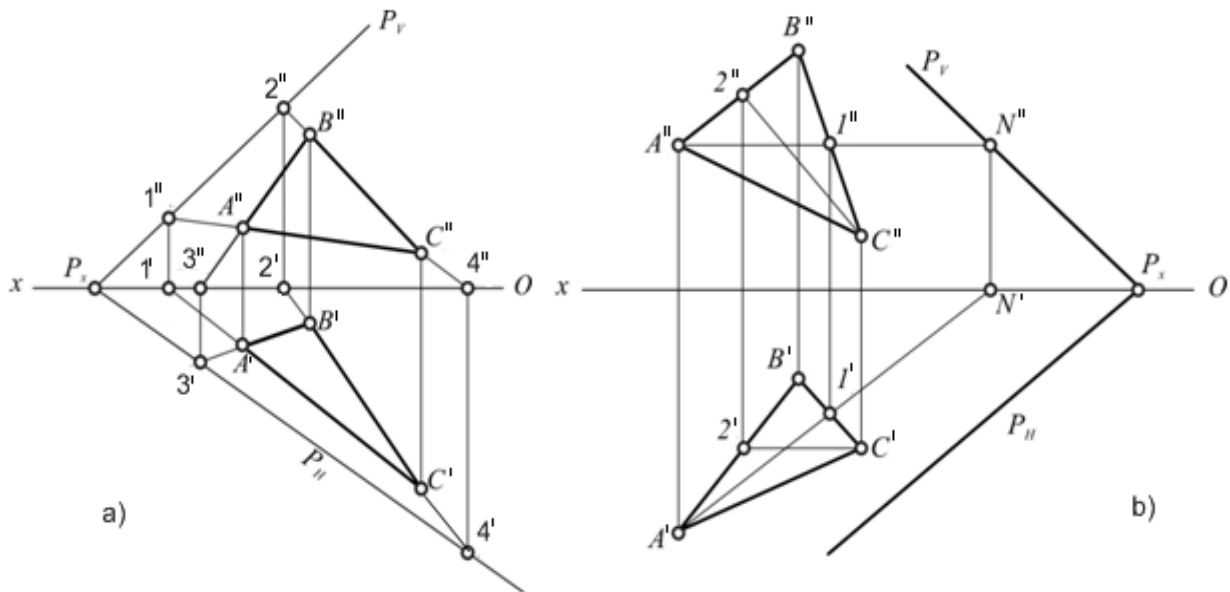

2-shakl

Epyurda (2-shakl, a) BC tomonning gorizantal izini yasash uchun, unda Z koordinatasiga teng nuqtani aniqlash kerak. Buning uchun tomonning gorizantal proeksiyasi B^1C^1 ning Ox o'qi bilan kesishish nuqtasi 2^1 topilib, proeksion bog'lanish chizig'i yordamida 2^{11} aniqlanadi. Frontal proeksiyasi $B^{11}C^{11}$ ning Ox o'qi bilan kesishish nuqtasi 4^{11} topilib, proeksion bog'lanish chizig'i yordamida 4^1 aniqlanadi. Gorizantal proeksiyasi A^1C^1 ning Ox o'qi bilan kesishish nuqtasi 1^1 da bo'ladi uning yordamida 1^{11} aniqlanadi. Frontal proeksiyasi $A^{11}C^{11}$ ning Ox o'qi bilan kesishish nuqtasi 3^{11} da bo'ladi uning yordamida 3^1 aniqlanadi. Hosil bo'lgan $3^1, 4^1$ va $1^{11}, 2^{11}$ larni tutashtirib, P_H va P_v izlarining uchrashuv nuqtasi P_x Ox o'qida frontal va gorizantal izlari hosil bo'ladi.

Tekislikdagi umumiy vaziyatdagi to'g'ri chiziqlarning izlari chizma chegarasidan chiqib ketadigan hollarda tekislikning gorizontali va frontalidan foydalanish qulay.

2-shakl b da $\triangle ABC$ ning A^1 – gorizontali va C^{11} – frontali o'tkazilgan. A^1 gorizontalinig frontal izi – A^{11} nuqtasidan $C^{11}2^{11}$ ga parallel qilib P_v – iz chiziladi. Hosil bo'lgan P_x nuqtadan A^11^1 ga parallel qilib P_H o'tkaziladi.

2-grafik ish.

S nuqtadan ABC tekisligacha bo'lgan masofa aniqlansin (Namuna).

Yechish. Masala quyidagi yasash algoritmi asosida yechiladi:

- ABC tekislikning gorizont va frontal chiziq lari proyeksiyalari o'tkaziladi;
- S nuqtaning S^1 va S^{11} proyeksiyalaridan perpendikulyarning m' va m'' proyeksiyalari m^1O , m^1M^1 va $m^{11}S^{11}$, $m^{11}S^1$ qilib o'tkaziladi;
- perpendikulyarning BBC tekislik bilan kesishgan nuqtasi S ning S^1 , va S^{11} proyeksiyalari aniqlanadi;
- m perpendikulyardan yordamchi gorizont proyeksiyalovchi M ($My M$) tekislik o'tkaziladi;
- ABC va M tekisliklar kesishish chizig'ining 3^14^1 va $3^{11}4^{11}$ proyeksiyalari yasaladi;
- tekisliklarning kesishish chizig'i proyeksiyalari 3^14^1 va $3^{11}4^{11}$ bilan, m'' perpendikulyarning kesishish S , nuqtasining S^1 va S^{11} proyeksiyalari aniqlanadi: $S^{11}=m^{11}m$, $3^{11}4^{11}$ va $S^{11}m^{11}$.

Chizmada hosil bo'lgan S^1S , va O^1S^{11} proyeksiyalar izlangan S, S masofaning proyeksiyalari bo'ladi. Uning haqiqiy o'lchami to'g'ri bo'rchakli S^1S^{11} ning S^{11} gipotenuzasidan iborat bo'ladi.

Agar tekislik xususiy vaziyatda berilsa, u holda berilgan nuqtadan tekislikkacha bo'lgan masofani aniqlash uchun qo'shimcha yasashlar talab etilmaydi.

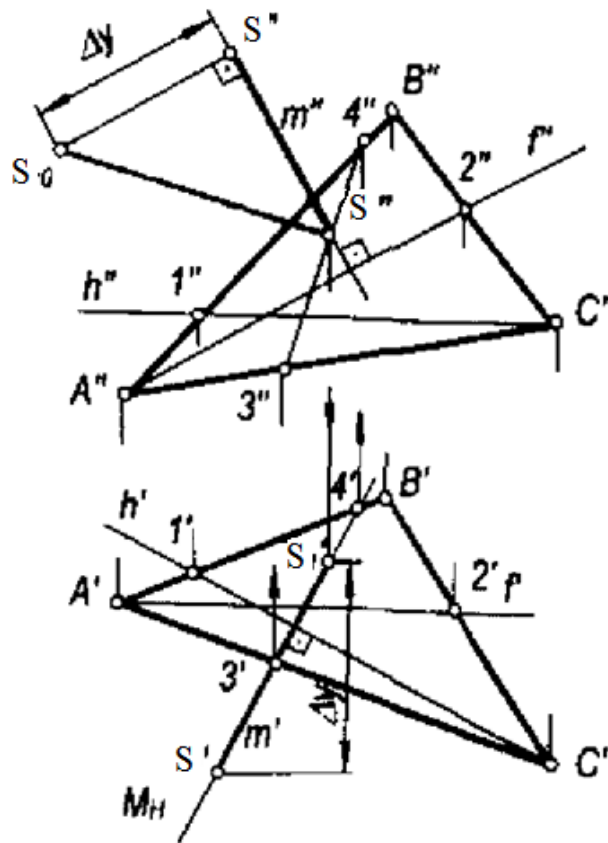

3-shakl

3-grafik ish.

Proeksiya tekisliklarini almashtirish usulidan foydalanib ABC tekislikni xaqiqiy kattaligini aniqlash (Namuna).

Umumiy vaziyatdagi tekislik uchta A,B,C nuqtalar orqali berilgan (4-shakl). Bu masalani yechish uchun yangi proeksiyalar tekisligini bir paytda ABC uchburchakka, hamda proeksiya tekisliklaridan biriga perpendikulyar vaziyatga keltirish kerak. Demak, yangi tekislik, berilgan tekislik bilan proeksiya tekisliklaridan birining kesishgan chizig'iga perpendikulyar bo'lishi kerak. Buning uchun ularning kesishish chizig'ini yasab o'tirishga hojat yo'q, chunki uning yo'nalishini tekislikning sath chiziqlari, ya'ni gorizontali va frontali orqali aniqlash mumkin.

Shuning uchun berilgan tekislikda sath chiziqlaridan birini, masalan, AH gorizontali o'tkazish kerak. Bu gorizontali yangi proeksiya tekisligi V_1 ning vaziyatini aniqlaydi. X_1 o'q $A^1 H_1$ ga perpendikulyar qilib o'rnatilsa bir yo'la ikki shart bajariladi: yangi V_1 tekislik ham H tekislikka, ham ABC uchburchakka perpendikulyar bo'ladi. Uchburchakning gorizontali uchlaridan yangi X_1 o'qqa perpendikulyar qilib proeksion bog'lanish chiziqlari o'tkaziladi. Bu chiziq'larga X_1 o'qidan Z_A, Z_B va Z_C kesmalar qo'yilib, uchburchakning bir chiziqda joylashgan yangi frontal proeksiyasi $A^{11}_1 B^{11}_1 C^{11}_1$ yasaladi. α ABC uchburchakning H tekislikka og'ish burchagining haqiqiy kattaligi bo'ladi.

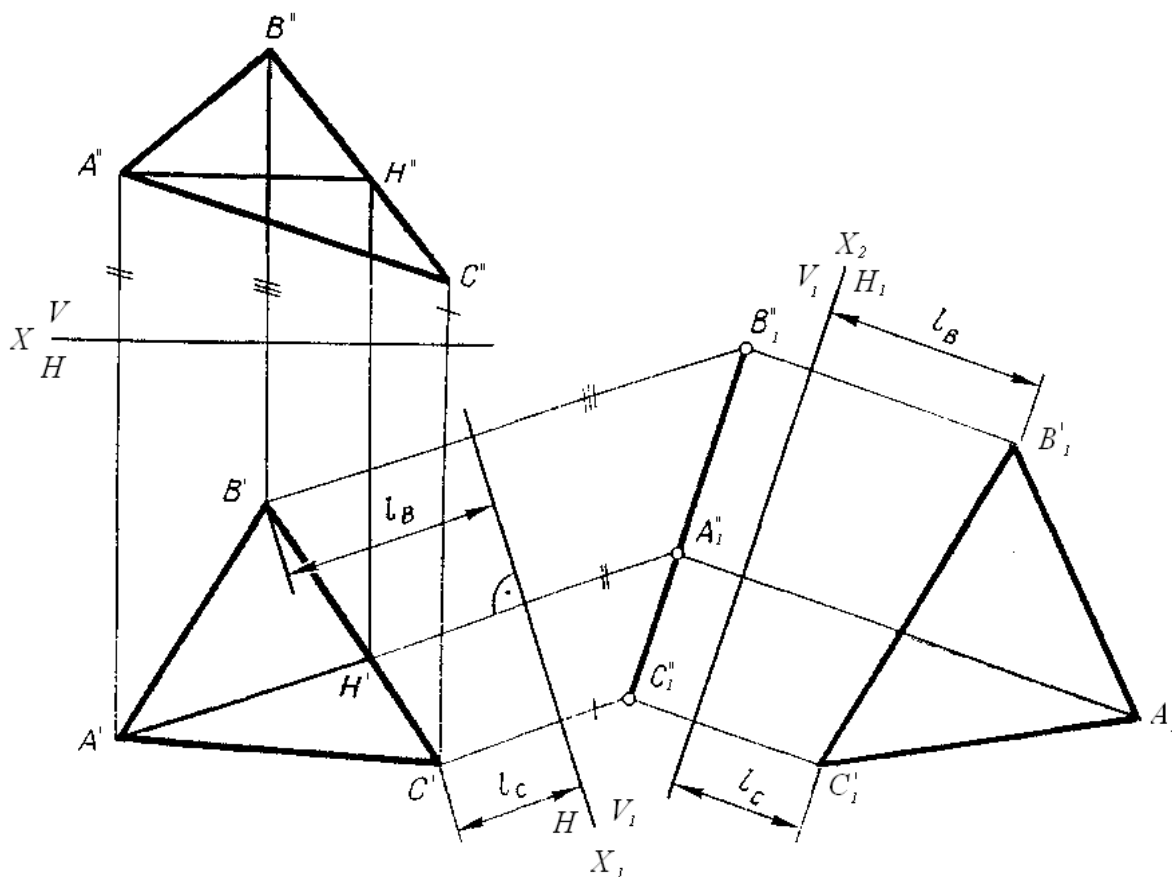

4-shakl

4-grafik ish.

Berilgan ikki ko‘rinish bo‘yicha uchinchi ko‘rinishini toping va kerakli qirqimini bajaring hamda aksonometriyasini quring, zururiy qirqimini bajaring (Namuna).

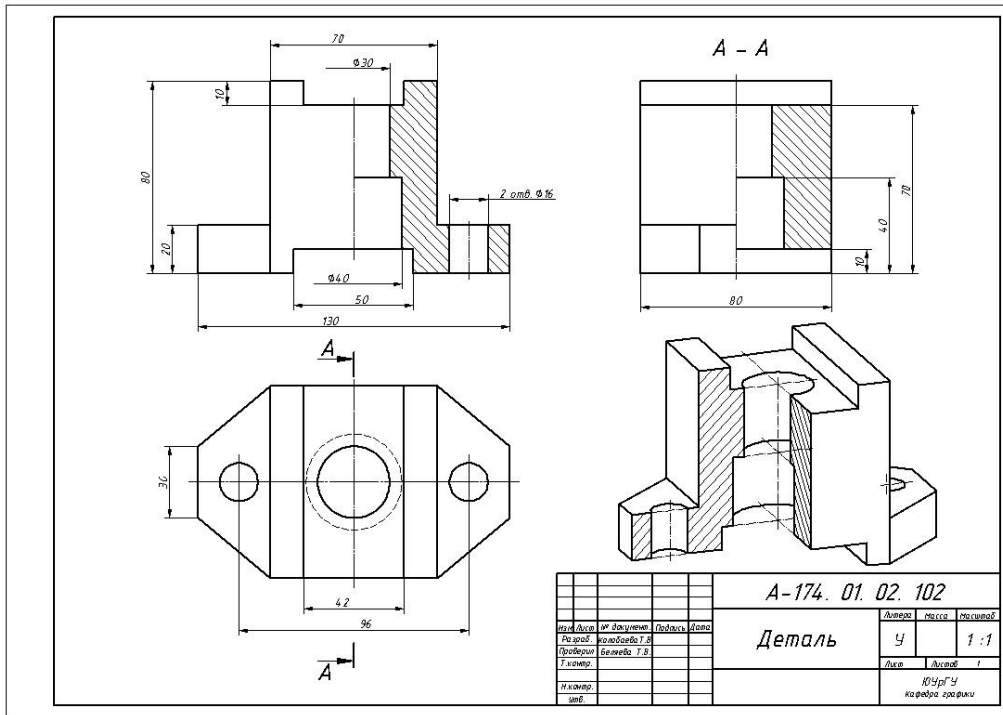

5-shakl

5-8 grafik ish.

Binoning arxitektura-qurilish chizmasi: plan, fasad, qirqim. A-birikmasining chizmasi (Namuna).

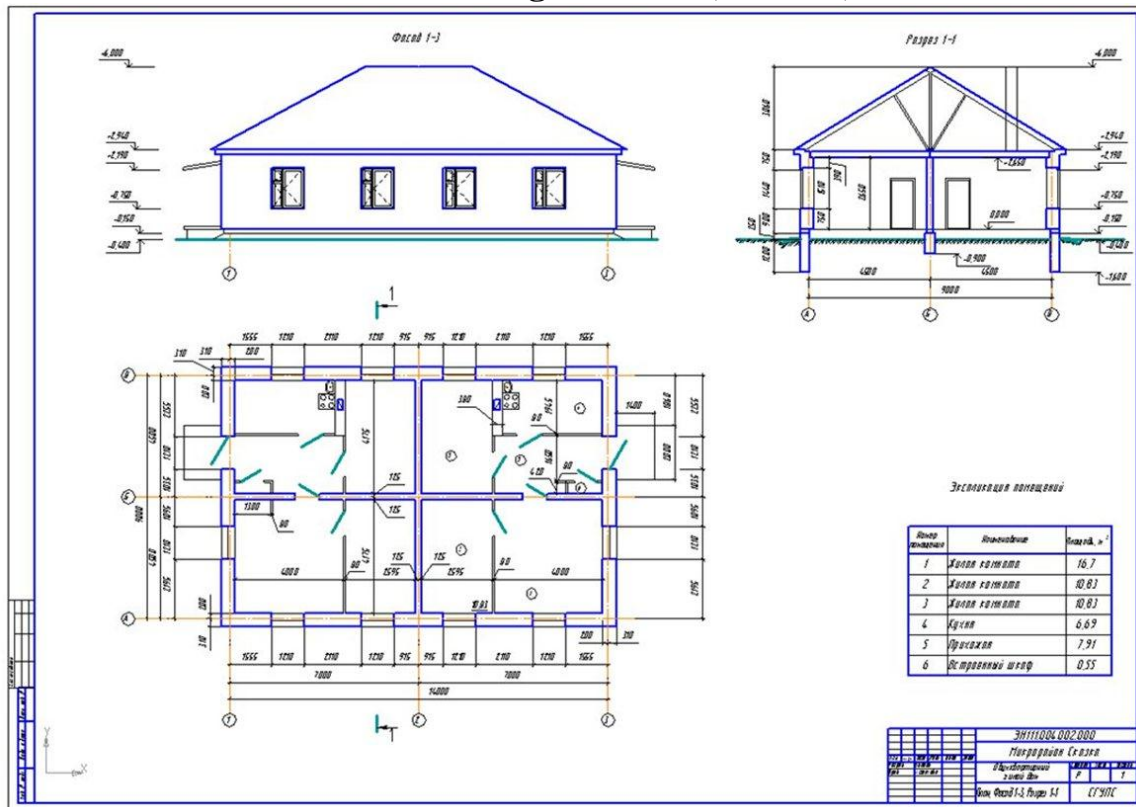

6-shakl

GRAFIK ISHLARGA OID KO'RSATMALAR VA NUMUNALAR
(2-semestrda)
1-grafik ish

Arxitektorlar usulida perspektiva qurish.

Bu misolda obyektning 11 qirrasini kartinaga tegib turgan vaziyatda bo'lgani uchun u qirra perspektivada o'zining haqiqiy balandligida tasvirlangan. Qolgan qirralarining qisqarib tasvirlanishi F_1 va F_2 uchrashish nuqtalari orqali aniqlanadi.

9-shaklda kartinani obyekt planiga nisbatan turli ko'rinishda tanlab olish ko'rsatilgan.

1. Kartina izi obyektidan olisroqda o'tkazilgan. Shunda obyekt kichikroq tasvirlanadi. Uning oldingi qirrasining perspektivasini yasash uchun obyektning tomonlari kartina bilan izi kesishguncha davom ettiriladi va T'_K , T_K deb belgilanadi hamda perespektiv tasvirning asosiga olib o'tiladi. Bu nuqtalar T_K va F_2 o'zaro tutashtiriladi. T'_K esa F_1 bilan tutashtiriladi. Shunda obyektning oldingi qirrasining asosi yasaladi.

2. Kartina izi obyektning oldingi qirrasiga tegib tasvirlangan. bu yerda ushbu qirra o'zining haqiqiy balandligida tasvirlanadi. Perespektivada bu qirra to'g'ridan-to'g'ri fasaddan olib o'tiladi.

3. Kartina izi obyekt planini kesib o'tkazilgan. Bu yerda kartina izi kesib o'tgan joy o'zining haqiqiy kattaligida tasvirlanadi. Kartina izigacha bo'lgan obyektning qismi haqiqiy kattaligidan kattaroq tasvirlanadi. Obyektning perspektivasini yasashda kartina izidagi N'_K , N_K ni perespektiv tasvirning asosiga olib o'tiladi va ular F''_1 va F''_2 lar bilan tutashtiriladi. Shunda obyektning kartina izidan oldingi qismi kartina asosidan oldinroqqa chiqib, ya'ni kattalashib tasvirlanadi.

Obyektning perspektiv tasviri solishtirilsa, uni qanday tartibda bajarish qulayligi aniqlanadi.

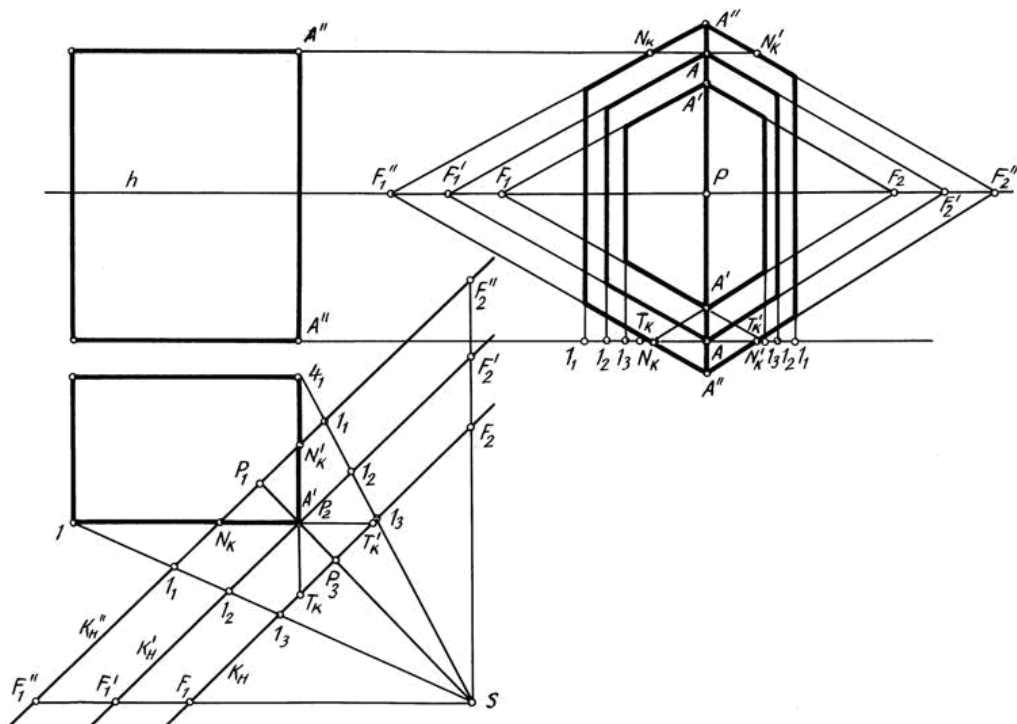

9-shakl

Ushbu perspektiv tasvir yasash usuli barcha usullar uchun umumiy bo‘lib, yasash usulining turiga qarab o‘zgarishi mumkin.

Turli sohadagi mutaxassislar o‘z kasblari nuqtayi nazaridan qarashib, har qaysisini qanoatlantiradigan usullar izlaganliklari oqibatida, perspektivada har turli yasash usullari vujudga kelgan. Shulardan biri keng ommalashgan va ancha qulay bo‘lgan “Arxitektorlar usuli” hisoblanadi.

Arxitektorlar obyektning plani va fasadidagi parallel to‘g‘ri chiziqlarning ufq chizig‘idagi uchrashish nuqtalaridan foydalanib ularning perspektiv tasvirlarini bajarishgan. Shu boisdan bu usul “Arxitektorlar usuli” deyiladi.

Arxitektorlar usulida perspektiva qurish (Namuna).

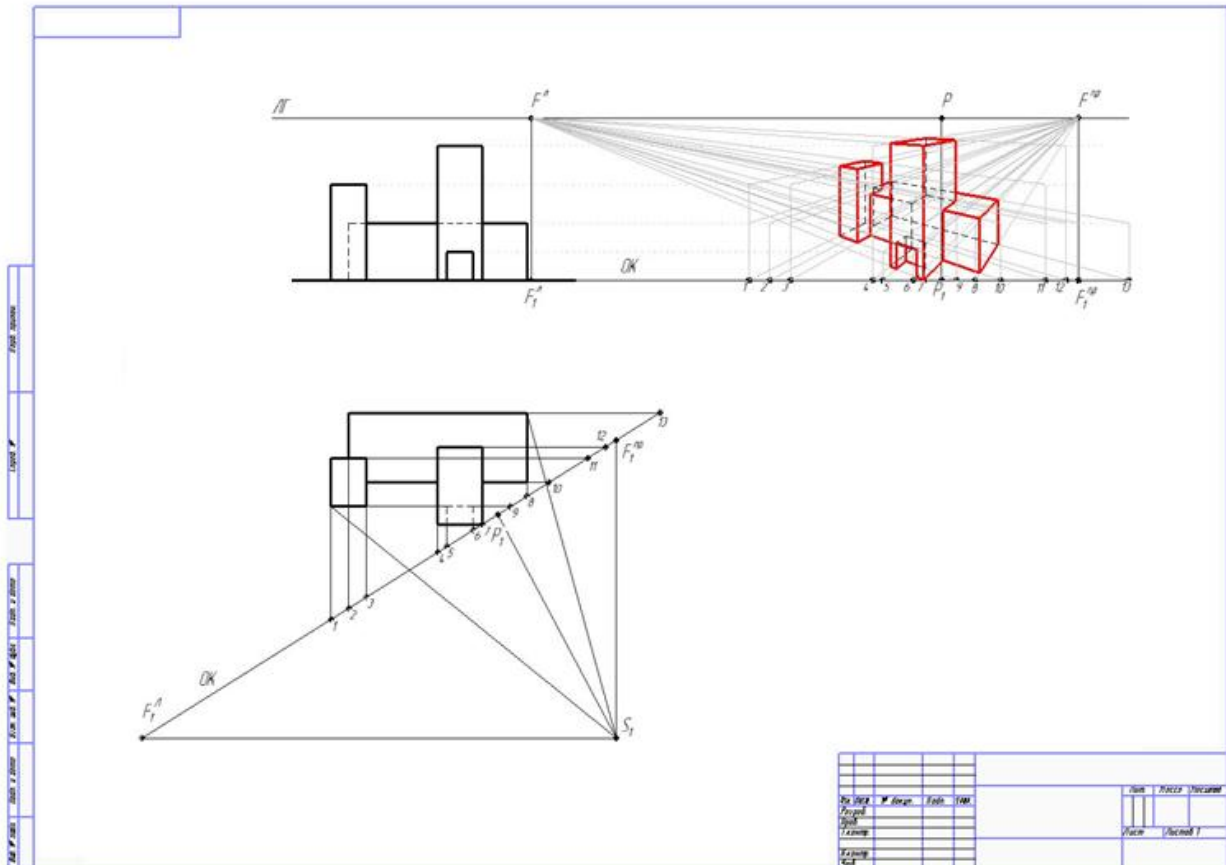

10-shakl

2-grafik ish

Topografik sirtga qurilish inshooti planini loyihalash. Vertikal qirqimini yasash.

Ko‘tarmaning tekis nishab bilan kesishishi

136-rasmda qiyaligi $i_k = \frac{2}{3}$ bo‘lgan tekis nishab va uchchala yon bag‘ining qiyaligi $i_k = \frac{5}{3}$ bo‘lgan ko‘tarmaning o‘zaro kesishish chizig‘ini yasash ko‘rsatilgan.

Buning uchun avval nishablik va ko‘tarma yon bag‘irlarining intervallari aniqlanadi:

$$L = \frac{1}{i} \quad \text{bo‘lgani uchun,} \quad L_H = \frac{3}{2} = 1,5 \text{ m,} \quad L_K = \frac{3}{5} = 0,6 \text{ m}$$

Intervallar ma'lum bo'lgach $L_K = 0,6 \text{ m}$ gorizontallar yordamida ko'tarma yon bag'irlarining kesishish chiziqlari D_7E_1 va C_7F_1 , $L_H = 1,5$ gorizontallar yordamida nishablik va ko'tarmaning kesishish chiziqlari $A_7E_1F_1B_7$ aniqlanadi.

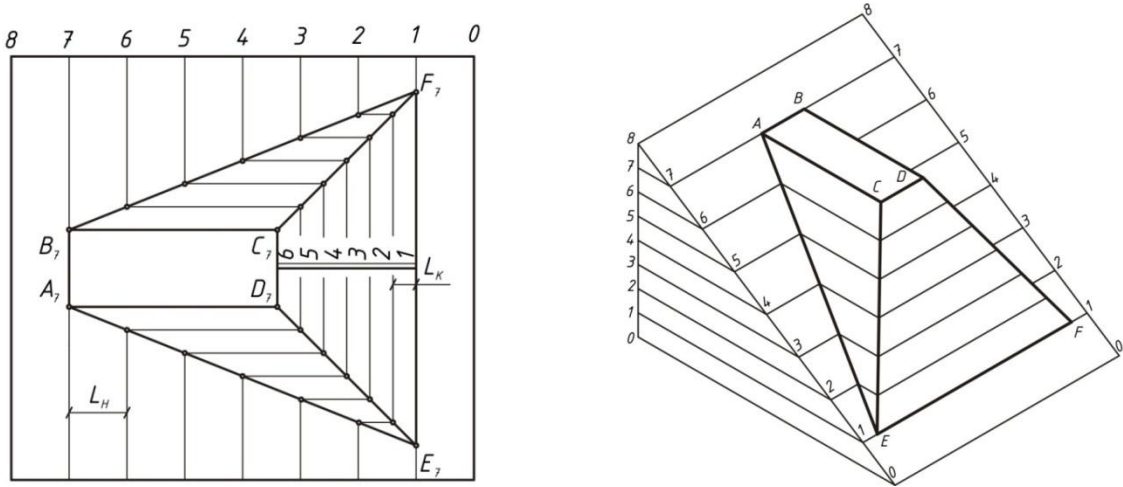

11-shakl

11-shaklda nishab va ko'tarma kesishish chiziqlarning yaqqol tasviri ko'rsatilgan.

Qurilish maydonchasida ko'tarma va qazilma chegaralarini aniqlash

Belgisi 27m bo'lgan gorizotal qurilish maydonchasini hosil qilish uchun yer ishlari chegaralarini aniqlash 12-shaklda ko'rsatilgan.

Qazilma nishablarining qiyaligi $i_K = 1:1$, ko'tarmaniki esa $i_K = 2:3$. Maydonchaga ko'tarilish yo'lagi $i_u = 1:1$ qiyalikka ega. Nol ishlar chizig'i joyning 27-chi gorizontaldan o'tadi.

Qazilma zonasida maydoncha bor perimetri bo'ylab kyuvet (oqava suv ariqchasi) qurilishi uchun kengaytiriladi. Endi barcha sun'iy nishabliklarning gorizotallarini yasash kerak. Qazilma gorizontallarining intervallari $L_K = 1 \text{ m}$, ko'tarmaniki esa $L_K = 1,5 \text{ m}$. Tekis nishabliklarning gorizontallari maydoncha tomonlariga mos ravishda parallel chiziqlar bo'ladi. Yarim doiraga yondosh qazilma sirti gorizontallari konsentrik aylanalar yo'ylaridan iborat uchi pastga qaragan konus sirtidir. Maydonchaga ko'tariluvchi yo'lakning intervali $L = 2 \text{ m}$ bo'lib, yon yoqlarining qiyaligi ko'tarma qiyaligi bilan bir xil $L_k = 1,5 \text{ m}$.

Yo'lak yon nishabining gorizontallari, uchi yo'lak qirg'og'ining eng yuqori S_{27} nuqtasida joylashgan, radiusi 1m dan oshib boruvchi konus gorizontallariga urinma qilib yasaladi.

Endi yasalgan har bir nishablikning gorizontallari yerning bir xil belgili gorizontallari bilan kesishib, tuproq ishlari chegarasini nuqtalarini beradi.

Chizmaning o'ng tomonida qiyaliklar va intervallarni grafik usulda yasash ko'rsatilgan.

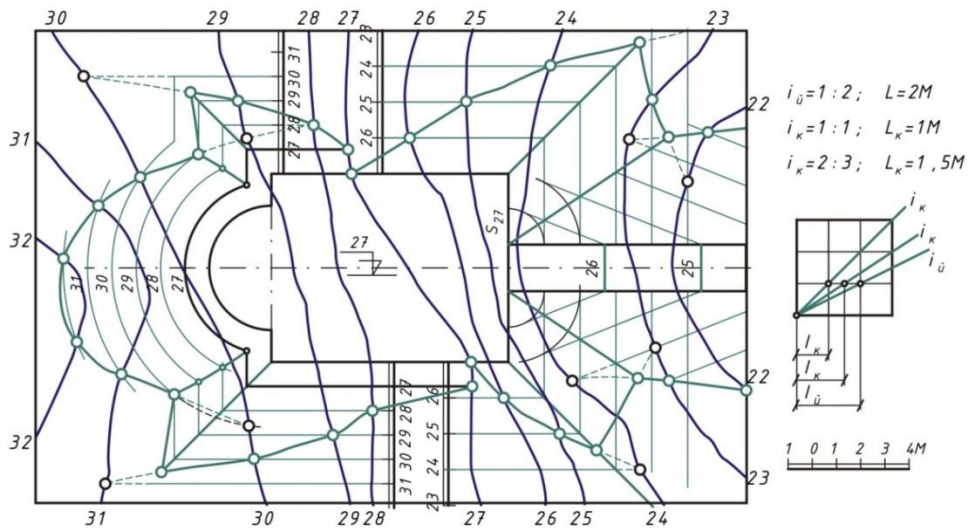

12-shakl

Topografik sirtga qurilish inshooti planini loyihalash. Vertikal qirqimini yasash (Namuna).

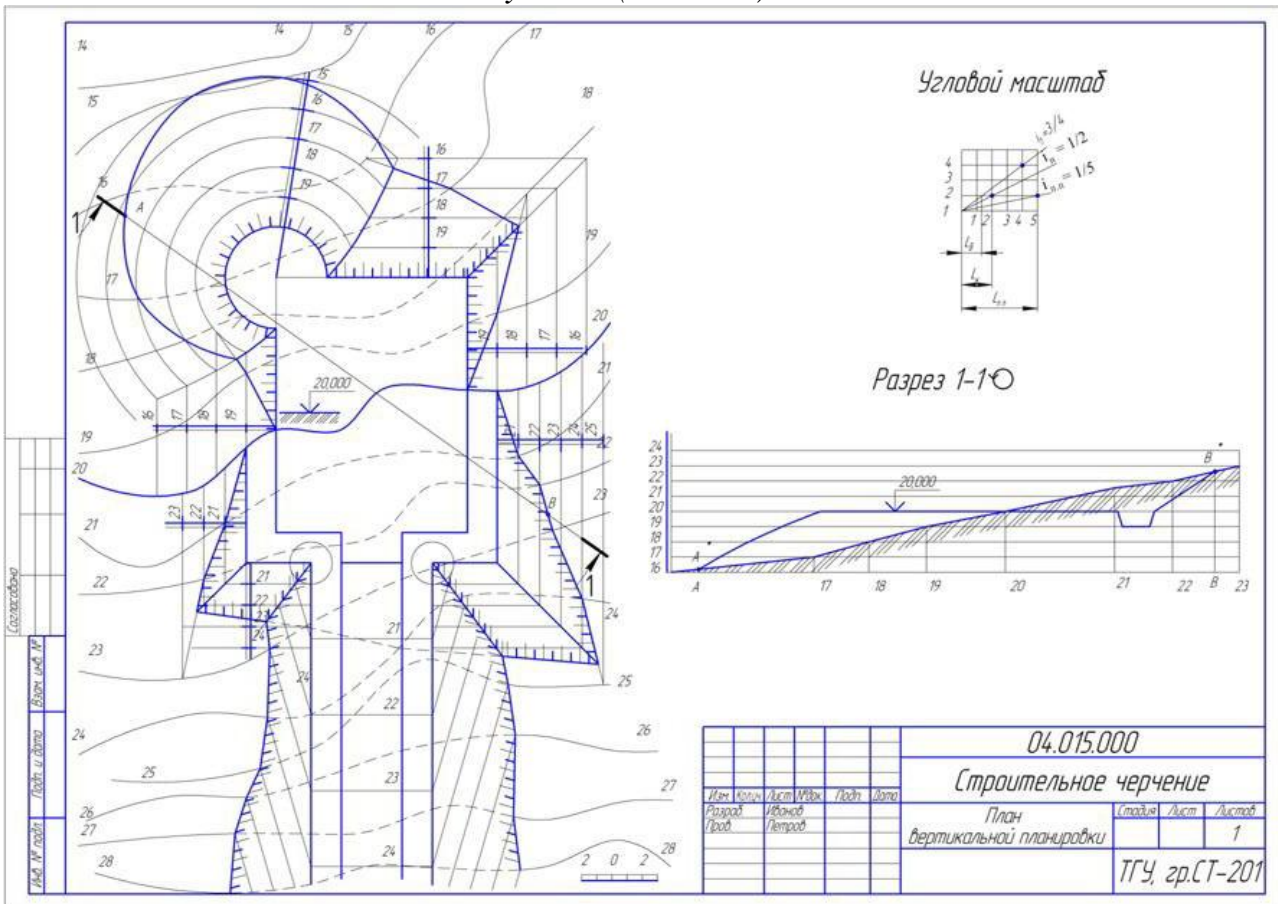

13-shakl

3-grafik ish

Ortogonal proeksiyada soyalar yasash

Bino fasadidagi soyalarni qurish (14-shakl).

Yechish. 1. Asosiy bino tomining eng yuqori gorizontal qirradi $a(a, a')$ ning $1(1', 1'')$ nuqtasidan qo'shimcha xona tomiga tushayotgan soyani qura-miz. Buning uchun A' nuqta orqali nur tekisligi $N(N_H)$ ni o'tkazamiz va uni qo'shimcha tom nishabi bilan kesishgan chizig'ini aniqlaymiz (1-qoida, 3 misolga qarang). $1''$ nuqtadan o'tgan yorug'lik nuri bu chiziq bilan kesishib $1(1', 1'')$ nuqtaning qo'shimcha tomdagi soyasi 1_s ni beradi.

N tekislikning qo'shimcha tom nishabini kesgan chizig'i karniz bilan φ burchakni tashkil qiladi. Bu burchak shu nishabning gorizontal tekislik bilan hosil qilgan burchagining xaqiqiy kattaligiga teng.

2. Asosiy tomning a qirradi (konyok) dan qo'shimcha tomga tushayotgan soyani aniqlaymiz. Bu soya nur yo'nalishi bilan ustma-ust tushadi (2 va 6 qoidalarga qarang).

3. Asosiy tomning $b(b, b')$ qirrasidan qo'shimcha tomga tushayotgan soyani aniqlash uchun shu qirraning $2(2', 2'')$ nuqtasidan qo'shimcha tomning davomiga tushayotgan yordamchi $2_s''$ soyani quramiz (bu soya $2'$ nuqta orqali o'tgan nur tekisligi va φ burchak orqali aniqlangan). $2_s''$ nuqta bilan $1_s''$ nuqtani tutashtirsak qidirayotgan b_s'' soya hosil bo'ladi.

4. 2 nuqta orqali o'tgan nur tekisligi yordamida asosiy tomning $2(2', 2'')$ nuqtasidan qo'shimcha xona devoriga tushayotgan $2_{1s}''$ soyani aniqlaymiz. $2_{1s}''$ nuqtadan $b(b', b'')$ qirra hamda $2(2', 2'')$ nuqta orqali o'tuvchi gorizontal qirraning soyalari o'tadi. Gorizontal qirraning soyasi nur yo'nalishi bilan ustma-ust tushadi (2 va 6 a qoidalarga karang), $b(b', b'')$ qirraning soyasi $b_s'' \parallel b'$ bo'ladi.

5. Asosiy tomning $c(c'')$ qirrasidan tushayotgan c_s'' soyani aniqlaymiz.

Buning uchun i chuqurlik yordamida qirraning ixtiyoriy $3(3'')$ nuqtasidan tushayotgan $3_s''$ soyani topib, u orqali $c_s'' \parallel c'$ qilib soya chizig'ini o'tkazamiz (7-qoidaga qarang). Agar $i = k$ bo'lib qolsa c_s'' soya 4 nuqta orqali o'tadi (bu holda $3_s''$ nuqtadan foydalanilmaydi).

6. Silindrik deraza o'rnidagi soya 13 va 14, a - shakllardagidek aniqlanadi. $c(c'')$ qirraning deraza chuqurligidagi soyasi $c_{1s}'' \parallel c_s''$ bo'ladi.

7. Qo'shimcha tomning $d(d'')$ qirrasining soyasi d_s'' ni k kattalik yordamida quramiz.

8. m kattalik orqali binoiing ye'' burchagining ye_s'' soyasini aniqlaymiz (6 va 6d- qoidalarga qarang). Sokolga tushayotgan e_{1s}'' soya ye'' ga parallel bo'lib, u p kattalik yordamida aniqlangan.

9. Eshik o'rnidagi soyani P kattalik yordamida quramiz.

10. Zina to'sig'i (parapet)ning zinaga tushayotgan soyasini 6d-qoidaga asosan aniqlaymiz. Buning uchun zinaning ko'tarilish burchagi a dan foydalanamiz. Zina to'sig'ining gorizontaal qirrasidan tushayotgan soya 6 b- qoidaga asosan topilgan, ya'ni soya nur yo'nalishi bilan ustma-ust tushgan.

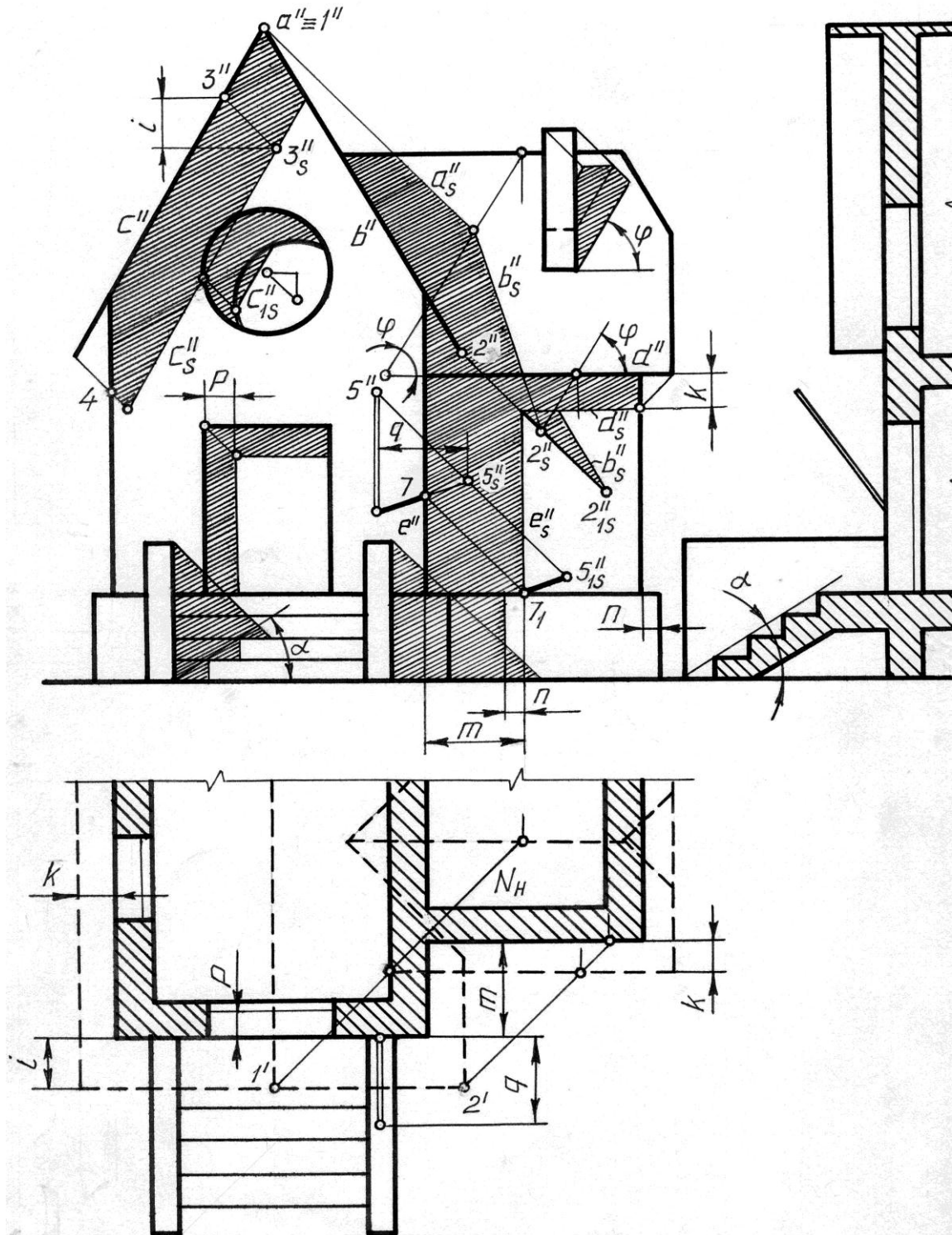

14-shakl

11. Bayroq o'rnatiladigan og'ma tayoqning 6'' nuqtasining soyasi o'zi bilan ustma-ust tushadi (3-qoidaga qarang). 5'' nuqtaning yordamchi 5_s' soyasini q kattalik yordamida aniqlab, uni 6'' nuqta bilan tutashtirsak tayoqning asosiy bino devoridagi 67 soyasi hosil bo'ladi. 7 nuqta ye'' burchakka tegishli bo'lganligi uchun 7' nuqta shu

burchakning soyasi ye_s'' ga tegishli bo'lad va u yorug'lik nuri orqali aniqlanadi. Tayoqning qo'shimcha xona devoridagi $7_1 5_{1s}''$ soyasi $6'' 7$ soyaga parallel bo'ladi (8-qoidaga qarang). $5_{1s}''$ nuqta nur orqali topilgan.

12. Dudburonning soyasini uning soya tashlaydigan qirralarining asoslaridan (φ burchak ostida chiziqlar chiqarib (qirralar orqali o'tgan nur tekisliklari tom nishabini φ burchak bo'yicha kesadi), ularni qirralarining uchlaridan o'tgan nurlar bilan kesishtirib aniqlaymiz (6-qoidaga qarang).

Ilova: Talabalarning qo'llanmadagi (mavzularni yoritish uchun berilgan) barcha masalalarni mustaqil ravishda yechib chiqishlari, ularga olgan bilimlarini mustahkamlashlari uchun yaxshi zamin bo'ladi. Shu maqsadda barcha masalalarning berilishi ilovada chizib qo'yilgan (talaba qo'llanmadan ish daftari sifatida foydalanib masalalarni yechadi).

Bundan tashqari ilovada grafik ishlar bajarish uchun topshiriqlar ishlanmalari ham berilgan.

Ortogonal proeksiyada soyalar yasash (Namuna).

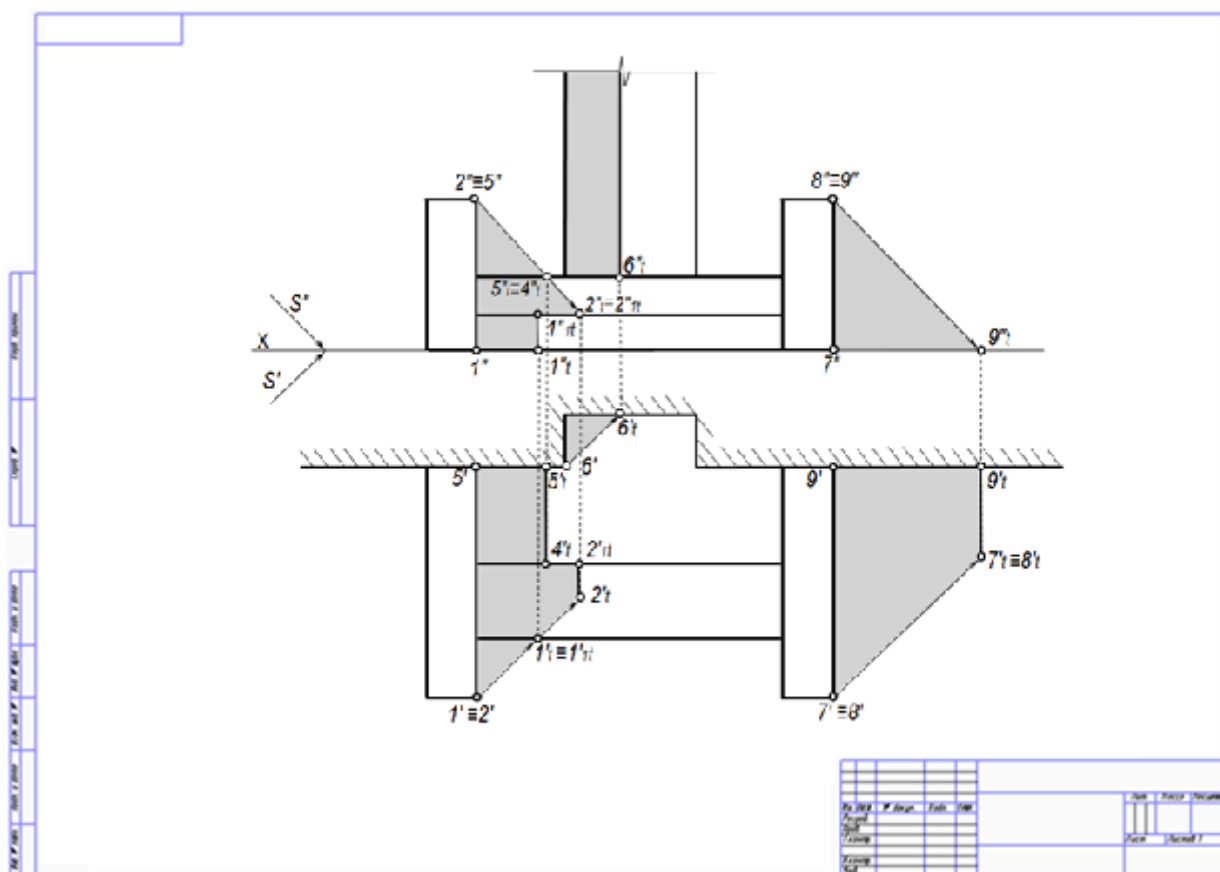

15-shakl

Ortogonal proeksiyada uyning soyasini qurish oid metodik ko'rsatma.

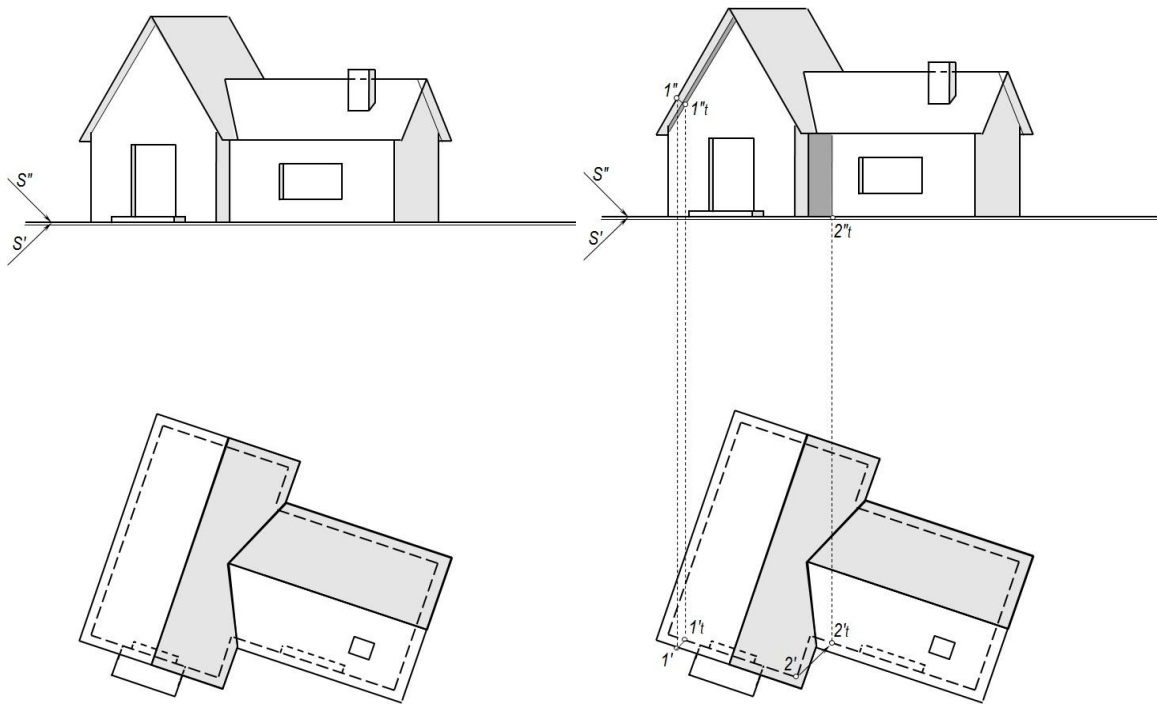

16-shakl

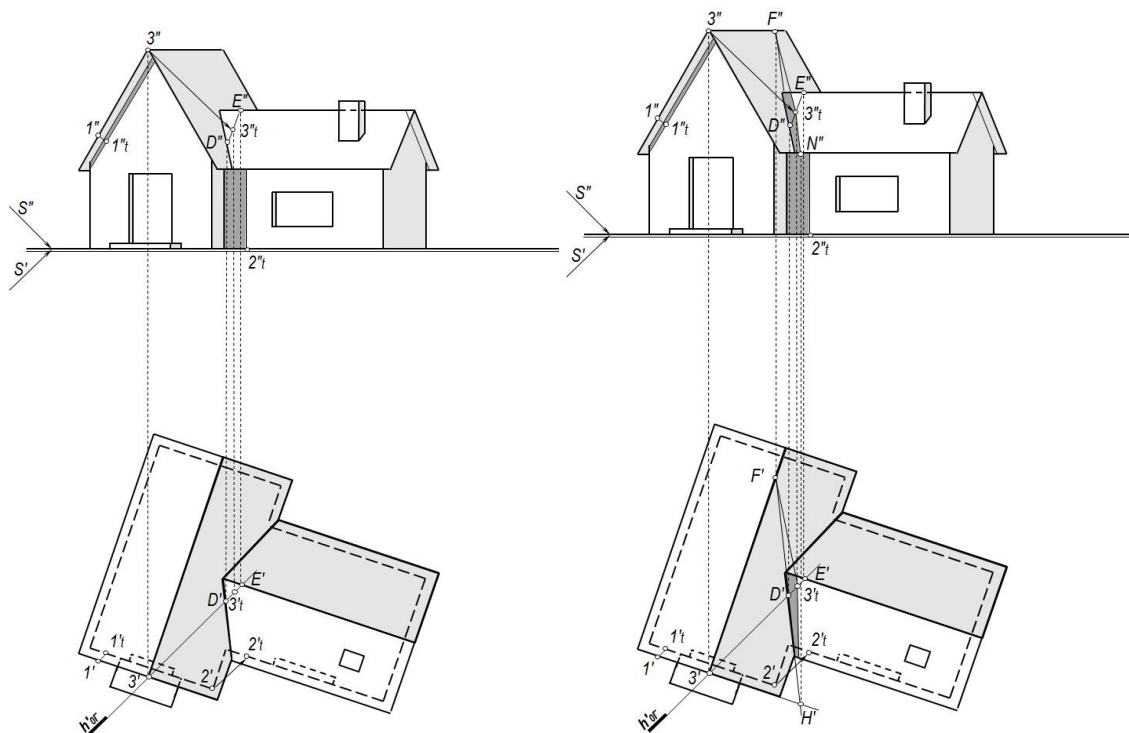

17-shakl

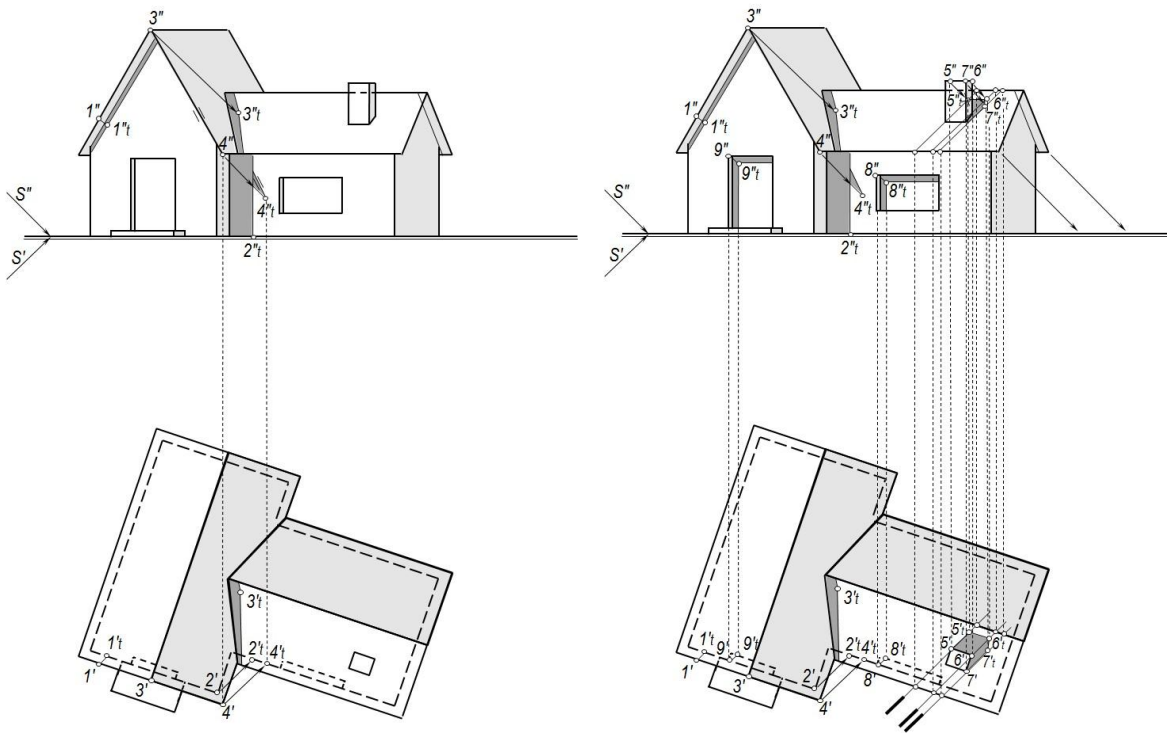

18-shakl

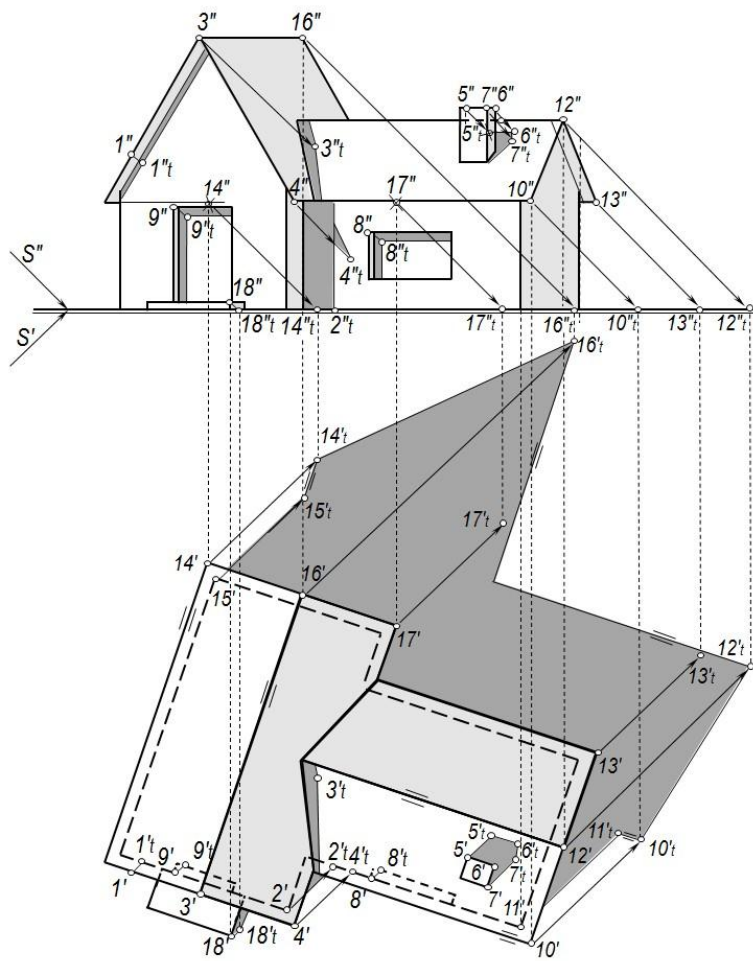

19-shakl

4-grafik ish

Bino perspektivasida soyalar yasash.

Soya qurish uchun pastga tushirilgan plandan foydalanish maqsadga muvofiqdir, sababi joyida chizilgan plan «siqilgan» bo‘lib soya qurishda sezilarli xatolarga olib kelishi va qiyinchiliklar tug‘dirishi mumkin.

Yorug‘lik manbai (Quyosh) kuzatuvchidan chap tomonda, orqada joylashgan. S va S^1 nuqtalar chizma chegarasidan tashqarida bo‘lganligi uchun, ularning o‘rnini chizmaga qo‘shimcha qog‘oz qo‘yib belgilab olamiz.

Asosiy tomning A nuqtasidan qo‘shimcha tomga tushayotgan A_S soyani aniqlash uchun A (A_1) nuqta orqali N (N_n) nur tekisligini o‘tkazamiz. Bu tekislik qo‘shimcha tomni 12 chiziq bo‘yicha kesib o‘tadi.

A nuqtadan o‘tgan nur 12 chiziqni kesib, A_S nuqtani beradi. B_S nuqtani ham xuddi A_S nuqtadek aniqlab, ularni o‘zaro tutashtirsak AB qirraning qo‘shimcha tomdagi soyasi $A_S B_S$ hosil bo‘ladi. B_S nuqtani 4 nuqta bilan tutashtirib $B_S 4$ soyani hosil qilamiz.

Binoning D (D_1) nuqta orqali o‘tgan old qirrasining yerga, qo‘shimcha xona devori va tomiga tushayotgan soyalarini qirra orqali o‘tgan N_1 (N_{1H}) nur tekisligi yordamida aniqlaymiz. Nur tekisligi yerni $D_S 1$, devorni 56_S , tomni esa 67 chiziqlar bo‘yicha kesib o‘tadi (6_S nuqta 6 nuqtadan yorug‘lik nuri o‘tkazib topilgan). Bu chiziqlar (67 chiziqning bir qismi) bino qirrasining yerdagi, devordagi va tomdagi soyalari bo‘ladi. 6_S nuqtani qo‘shimcha tomning gorizontaal qirralarining uchrashuv nuqtasi bilan tutashtirsak, shu qirraning devordagi soyasi hosil bo‘ladi (qirra devorga parallel bo‘lgani uchun soyasi o‘ziga parallel bo‘ladi). Eshikdagi soya G (G_1) nuqta orqali nur tekisligi o‘tkazib topilgan (20-shakl)

Asosiy tomning og‘ma qirrasidan bino devoriga tushayotgan soya qirraga tegishli ikkita nuqtaning soyasi orqali quriladi (chizmada bitta Ye nuqtaning soyasi Ye_S ni topish ko‘rsatilgan).

Dudbo‘rondan tomga tushayotgan soya dudbo‘ron qirralari orqali vertikal nur tekisliklari o‘tkazib, ularni tom nishabi bilan kesishtirib topilgan.

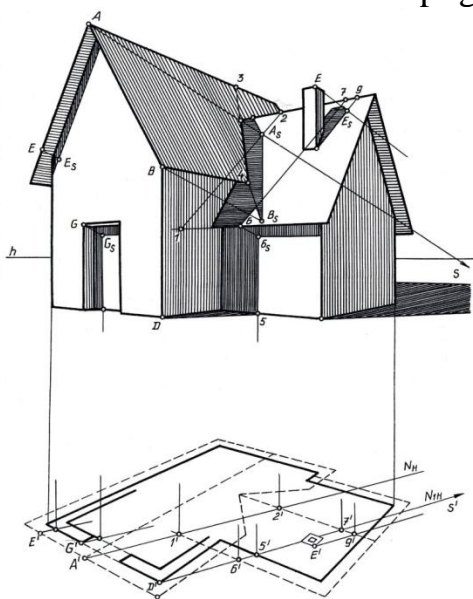

20-shakl

Bino perspektivasida soyalar yasash (Namuna).

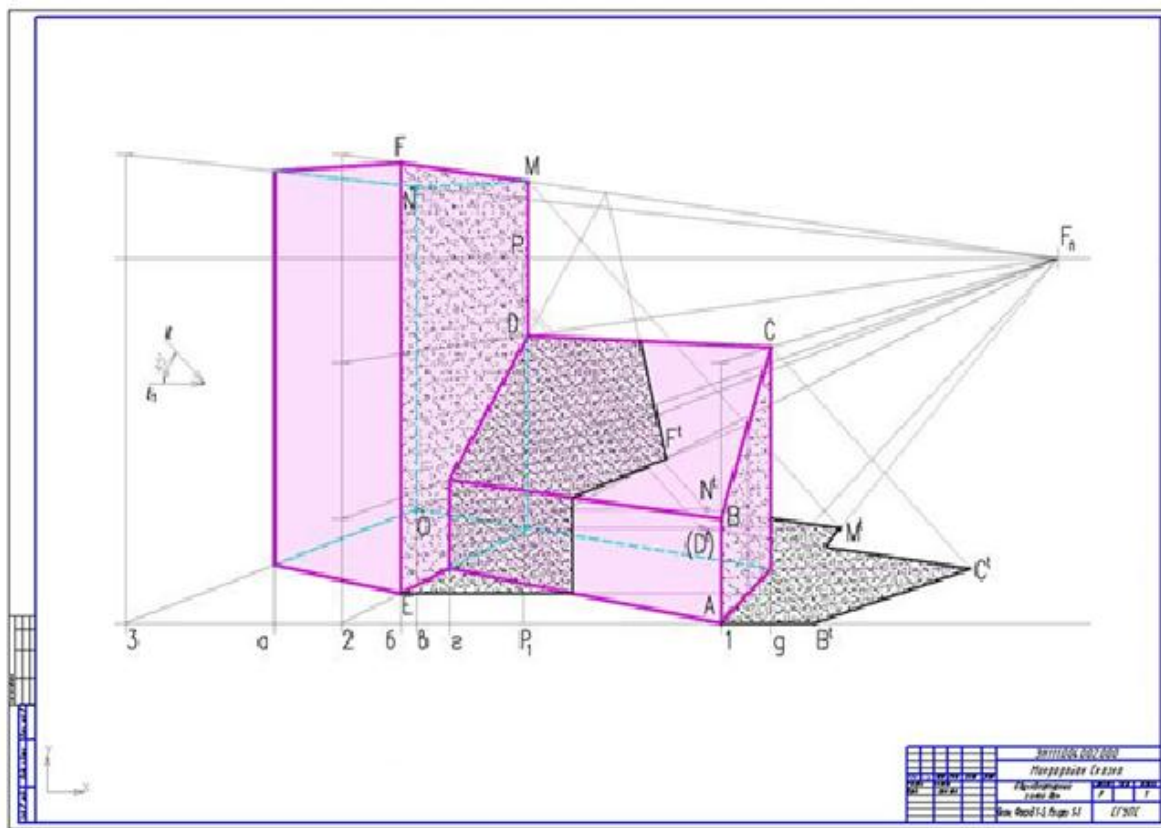

21-shakl

5-grafik ish

Qurilish konstruksiyalarining chizmalari. Ularning turlari va shartli belgilari.

(Shartli belgilardan foydalanib grafik ishni bajaradi)



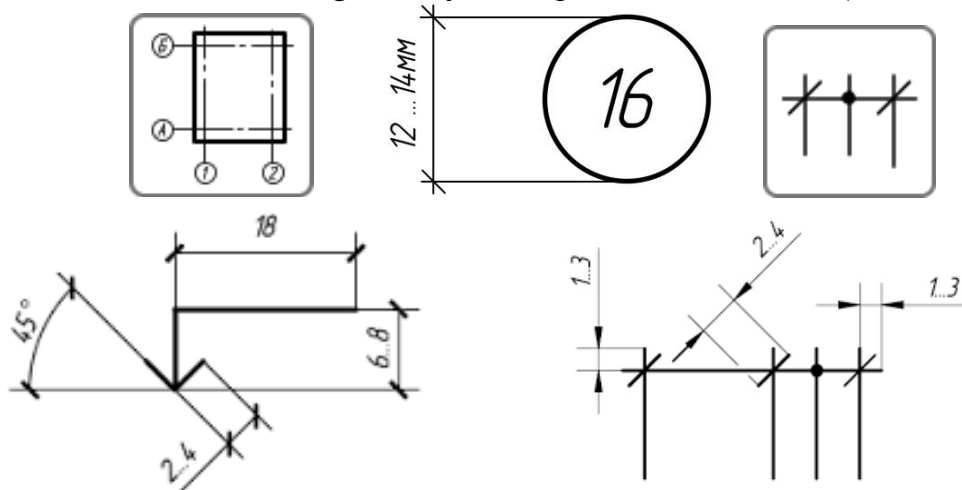









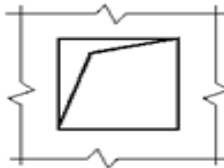

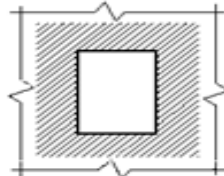
Qurilish binolarining planlarida, qirqimlarida, fasadlarida satxlarning shartli belgilari birinchi qavat poliga nisbatan ko'rsatiladi. Birinchi qavat polining satxi shartli ravishda <<nolinchi>> satx deb qabul qilinadi. Fasad va planlarda satxlar tokchalarda strelkalar bilan ko'rsatiladi. Bunday xollarda strelkalar 45° burchak ostida bo'lib, 2-4 mm. uzunlikdagi asosiy chiziq bilan ko'rsatiladi (22-shakl).

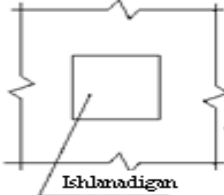

22-shakl

Deraza va eshiklarni o‘rinlarini shartli belgilari.

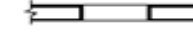
Jadval 1.1

№	Nomi	Ko‘rinish	
		Planda	Qirgimda
1	Devorda choraktaliksiz eshik yoki deraza o‘rni		
2	To‘ldirishi kerak bo‘lmagan teshik		
3	Yopib yuboriladigan deraza o‘rni		
4	Ochiq holda qoldiriladigan deraza o‘rni		
5	Choraktaliksiz deraza o‘rni		
6	Choraktalik deraza o‘rni		
7	1:200 mashtabdan kichik bo‘lgan tayyor rom		

Bino elementlarining shartli belgilari GOST 21.107-78 da ko‘rsatilgan. Jadvalarda oyna va eshiklarning shartli belgilari (jadval 1.1), ularning ochilishi ko‘rsatilgan. (jadval 1.2-1.3).

4 – jadvalda pardevorlarning va kabinalarning (dushxona.shaxsiy gigiena xonalarining) shartli belgilari ko‘rsatilgan. M 1: 200 dan kichkina mashtablarda pardevorlar bitta chiziq bilan ko‘rsatishga ruxsat etiladi: (jadval 1.4).

5 – jadvalda zinapoya va panduslarning shartli belgilari ko‘rsatilgan (jadval1.5).













6 – jadvalda devorlardagi har xil kanallarning shartli belgilari ko‘rsatil gan. (jadval 1.6).

7 – jadvalda san-tex. Qurilmalarining shartli belgilari ko‘rsatilgan. (jadval1.7).

8 – jadvalda ba’zi bir isitish asboblarning shartli belgilari ko‘rsatilgan. (jadval1.8).









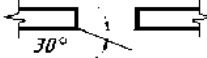

Fasadda derazalarni ochilishini shartli ko‘rinishi

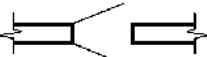
Jadval 1.2

Nomi	Ko‘rinish
onga ochiladigan derazalar	
A) Toshqariga	
B) Ichkariga	
Tepaga ochiladiga derazalar	
A) Toshqariga	
B) Ichkariga	
O‘rtadagi aylanib ochiladigan derazalar	
A) Gorizontaal o‘q atrofida	
B) Vertikal o‘q atrofida	
Surilib ochiladigan derazalar	
A) tepaga	
B) yonga	
Ochilmaydigan yoki ochilish belgilarisiz derazalar	
Tepaga ochiladigan ikki tabaqali derazalar	
A) Toshqariga	
B) Ichkariga	
V) ichkariga va tashqariga	
Yonga ochiladigan ikki tabaqali deraza	
A) Toshqariga	
B) Ichkariga	
V) ichgariga va tashqariga	
Tepaga va pastga ochiladigan ikki tabaqali deraza	

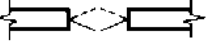
Planda eshiklarni ochilishini shartli ko‘rinishi

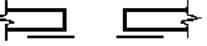
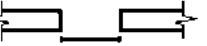
Jadval 1.3.

Nomi	Ko‘rinish
Bir tabaqali choraktaliksiz o‘rindagi eshik (darboza):	
A) chapga ochiladigan	
B) o‘nga ochiladigan	
Ikki tabaqali choraktaliksiz o‘rindagi eshik (darboza)	
Taxlanadigan choraktaliksiz o‘rin-dagi eshik (darboza)	
Bir tabaqali choraktalik o‘rindagi eshik (darboza) :	
A) chapga ochiladigan	
B) o‘nga ochiladigan	
Ikki tabaqali choraktalik o‘rindagi eshik (darboza):	
Bir tabaqali tebranuvchan eshik	
Bir tabaqali surilib ochiladigan eshik (darboza)	
Ikki tabaqali surilib ochiladigan eshik (darboza)	
Ko‘tarib ochiladigan eshik (darboza)	
Aylanuvchan eshik	



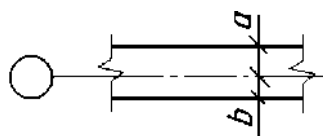
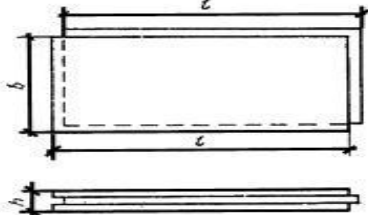
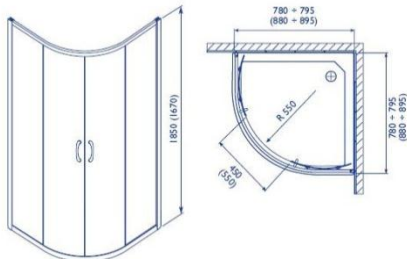
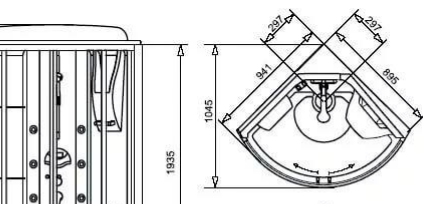
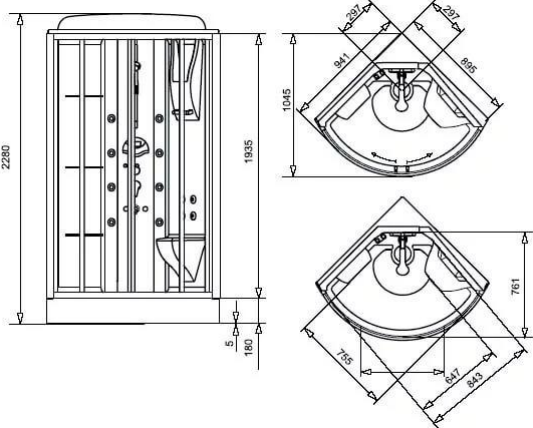

Devorlar va kabinalar shartli belgilari.

Jadval 1.4.

Nomi	Koʻrinish	
	Planda	Qirqimda
Devor, parda devor		
Parda devor A) shitlardan yigʻilgan		
B) shisha bloklardan yigilgan		
Dush kabinalari		
Kabinalar (shaxsiy gigiena uchun)		
1:200 mashtabdan kichik		
1:200 mashtabdan katta		

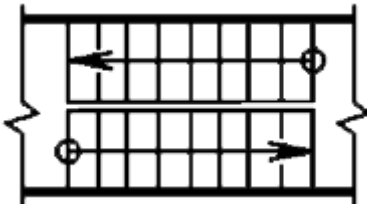
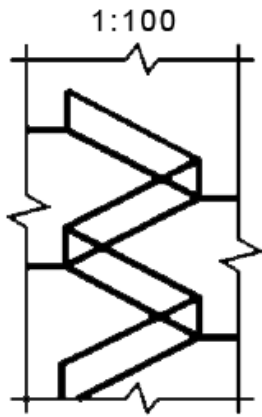
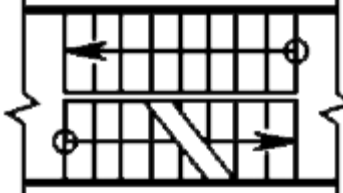
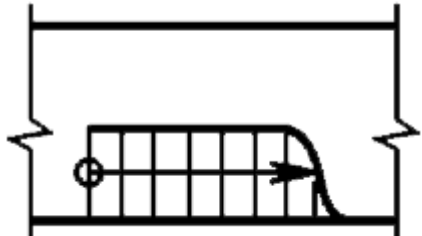
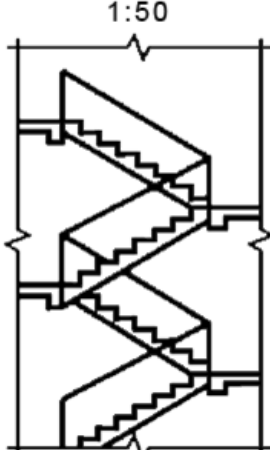
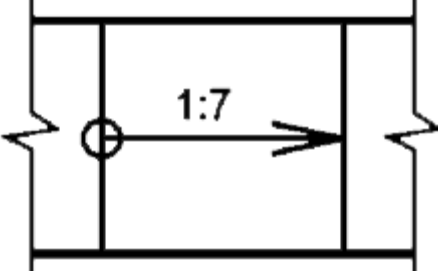
Zinalar va panduslarni shartli belgilari



Jadval 1.5

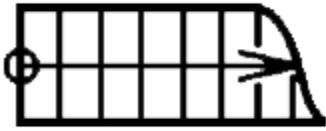
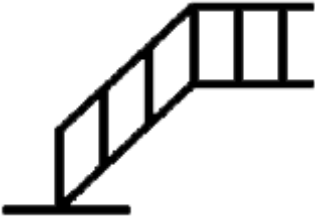
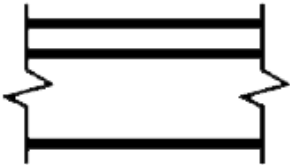
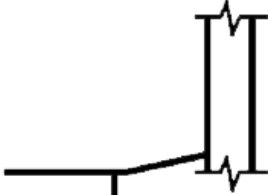



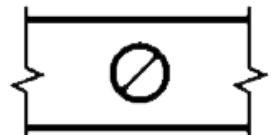
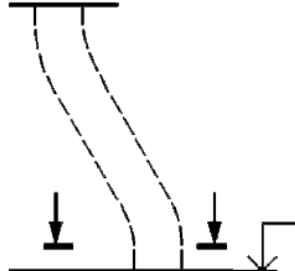
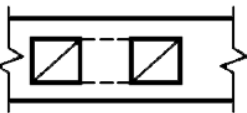

Nomi	Ko‘rinish	
	Plandam	Qirgimda
Zinalar:		
1. Yuqori marsh		
2. Oraliq marsh		
3. Pastki marsh		
Pandus		
To‘g‘ri vaziyatda joylashgan zina		
Og‘ma		

vaziyatda joylashgan zina		
Qiyalik (Otmostka)		

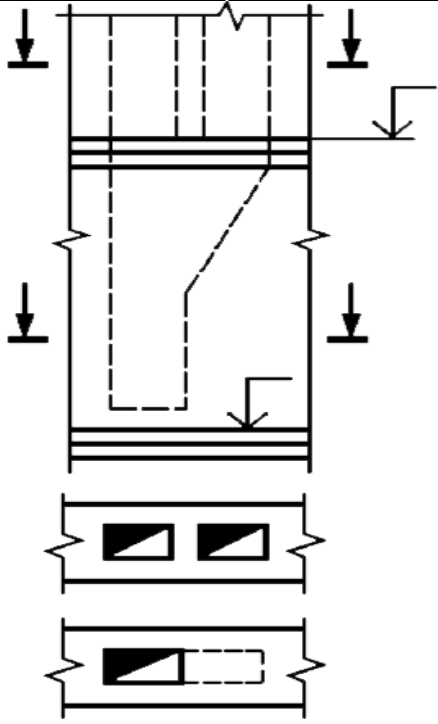
Devorlardagi har xil kanallarni shartli koʻrinishlari





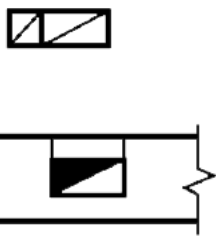









Jadval 1.6





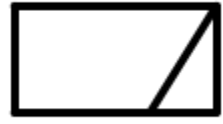





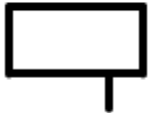





Nomi	Koʻrinish
	Planda
M 1:200 boʻlgan chizmalarda shaxtalar va kanalar	 
M 1:50 va 1:100 boʻlgan chizmalarda:	 
Tutin tortuvchi kanal (qattiq yoqilgi)	 



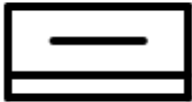



<p>Tutin tortuvchi kanal (suyuq yoqilgi)</p>	
<p>gaz uskunalaridan chiqqan gazlarni tortuvchi kanal</p>	
<p>ventilyatsiya kanallari va shaxtalari</p>	
<p>O'zgaruvchan kesimli, egilgan tutin tortuvchi kanallar:</p>	
<p>egilgan kanallar</p>	
<p>shoxlanuvchi kanallar</p>	
<p>o'zgaruvchan kesimlik ventilyatsiya shaxtasi</p>	

6-grafik ish
Sanitar-texnika uskunalarining shartli belgilari.
Sanitar texnik qurilmalarning shartli belgilari.
(Shartli belgilardan foydalanib grafik ishni bajaradi)

Jadval 1.7





Nomi	Ko‘rinish	
	Planda	Qirqimda
Rakovina		
Yuvish anjomi bir bo‘linmalik		
Yuvinish anjomi bir bo‘linmalik		
Guruhlashgan anjomi yuvinish		
Aylnasimon anjomi yuvinish		
Hammom (vanna)		
Oyoqli vanna		
Poddon		

Bidet		
Unitaz		
Chashagen		
Devorga joylashadigan pissuar		
Polga joylashadigan pissuar		
Shifoxona drenaji		
Trap		
Varonka		
Ichki suv ushlab turuvchi varonka		

Dush xanisi		
Suv ichish fantani		
Avtomatik gazlangan suv		 

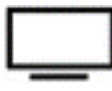
Isitish asboblarning shartli koʻrinishlari

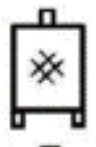
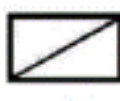
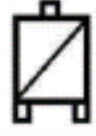
Jadval 1.8

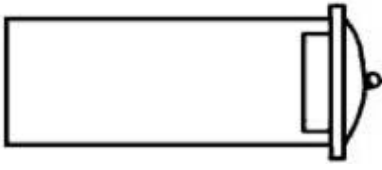
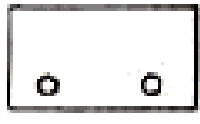
Nomi	Koʻrinish	
	Planda	
Suv isitkich:		
Qattiq yoqilgʻida		
Suyuq yoqilgʻida		
Gazli		
Elektro		
Oshxona plitasi		

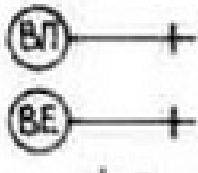
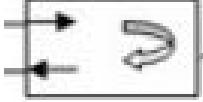
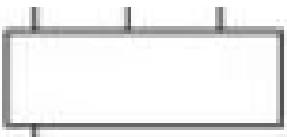
Gazli Har xil yoqilg'ida ishlaydigan	
Isitish kozoni	
Isitish vannasi	

GRAFIK ISHLAR UCHUN VARIANTLAR

1-semestr

1,2,3-grafik ishlar varianti

№	A			B			C			S		
	X	U	Z	X	U	Z	X	U	Z	X	U	Z
1	110	85	50	25	45	5	90	5	105	100	25	20
2	105	90	55	15	50	15	85	15	95	30	90	100
3	110	10	60	85	80	5	30	40	90	45	10	25
4	10	100	30	40	40	100	115	55	5	25	30	10
5	115	95	85	95	25	5	10	5	50	60	85	10
6	90	90	80	65	10	10	10	20	65	35	65	10
7	110	90	90	95	0	20	10	65	45	70	90	10
8	100	5	35	10	30	95	30	100	5	80	70	70
9	100	25	15	65	85	90	20	10	55	45	75	15
10	115	30	10	80	90	95	10	10	60	40	85	25
11	80	5	85	10	85	40	125	60	5	40	20	10
12	110	40	90	85	100	20	30	15	60	110	10	20
13	110	60	10	25	110	50	90	5	90	45	35	20
14	15	30	10	50	90	95	120	10	50	100	85	15
15	115	65	90	75	5	5	10	90	40	30	25	80
16	30	80	90	55	10	10	110	65	30	85	15	65
17	10	85	95	30	5	25	115	50	5	65	10	85
18	115	30	100	85	100	40	10	5	55	100	10	30
19	10	55	90	100	15	50	30	95	15	85	100	90
20	30	65	10	55	5	80	110	90	40	95	25	10
21	30	50	85	155	5	45	50	105	5	40	10	25
22	15	90	65	55	5	5	120	40	90	100	80	25
23	30	90	40	55	20	100	110	60	15	30	20	10
24	30	10	60	115	50	110	50	90	5	95	20	35
25	115	10	30	80	95	90	10	50	10	30	15	85
26	60	85	5	130	40	85	15	5	60	100	10	20
27	30	35	5	120	95	30	100	5	100	50	70	70
28	15	95	95	30	25	5	115	50	70	65	15	95
29	15	10	30	50	95	90	120	60	10	90	25	85
30	30	15	25	65	90	85	110	55	10	85	10	75

4-grafik ishlar varianti.
Oddiy vertikal qirgim uchun na'muna va variantlar

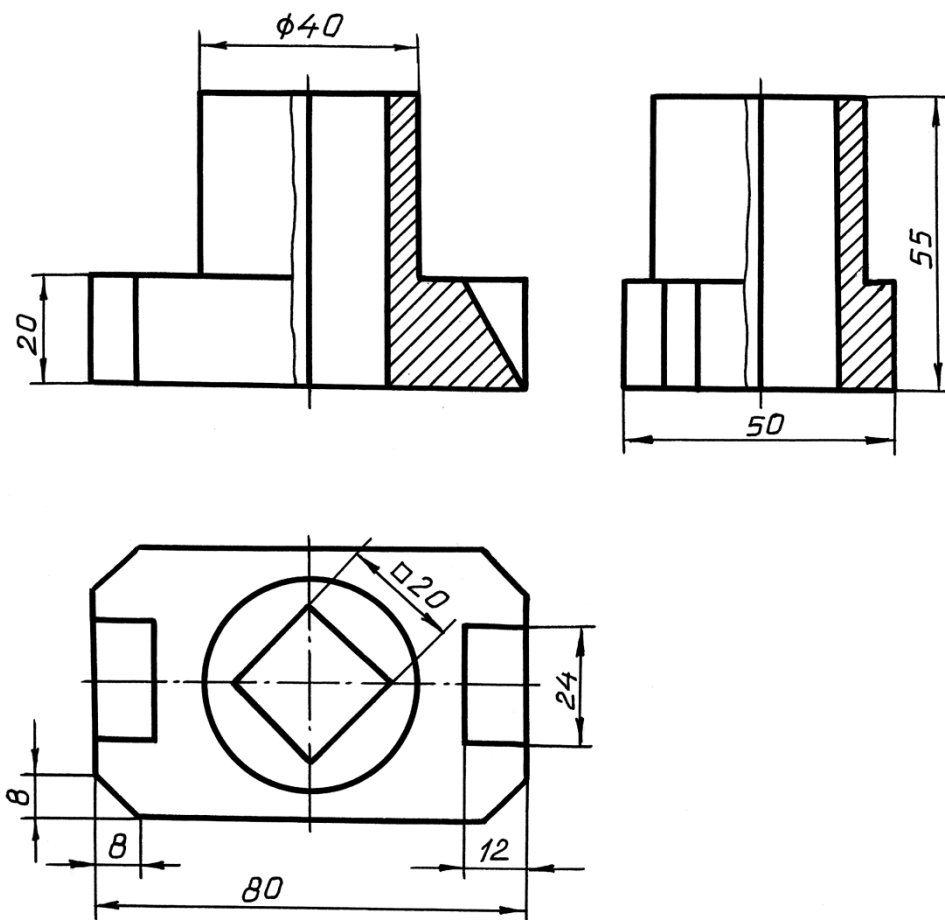

Izometriya a:b:c=1:1:1

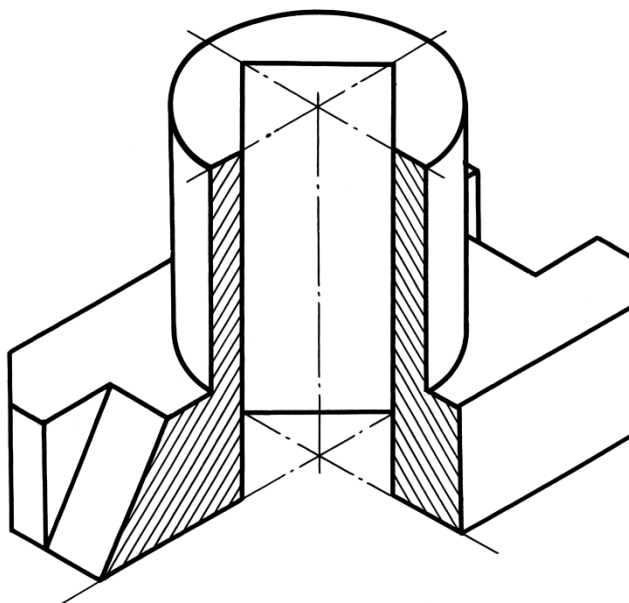

1-variant

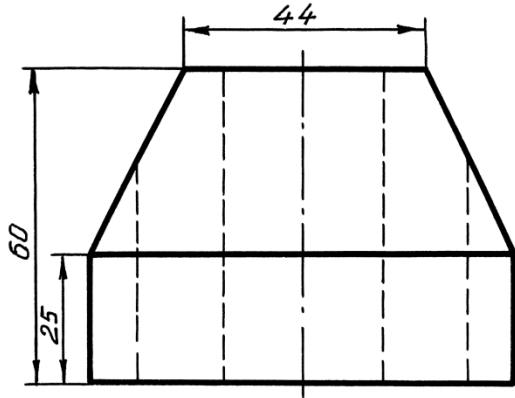

2-variant

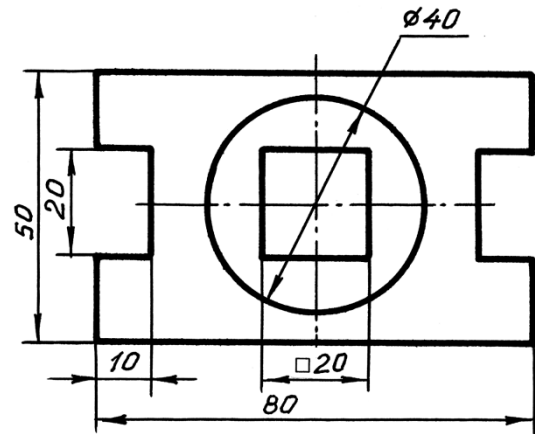
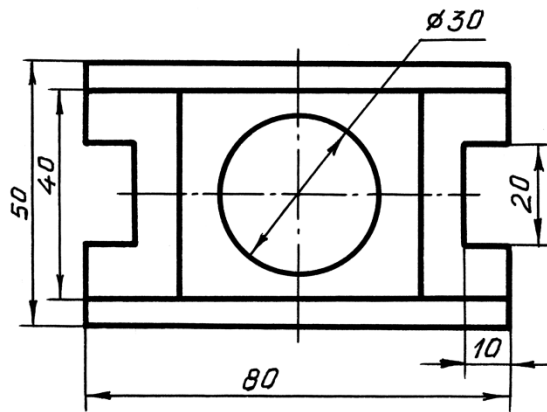
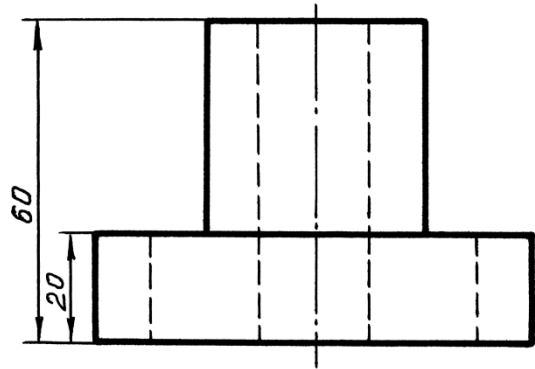

3-variant

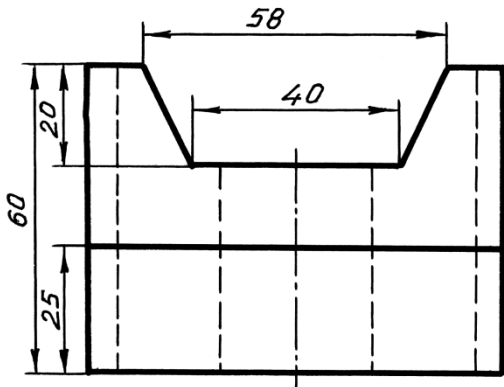

4-variant

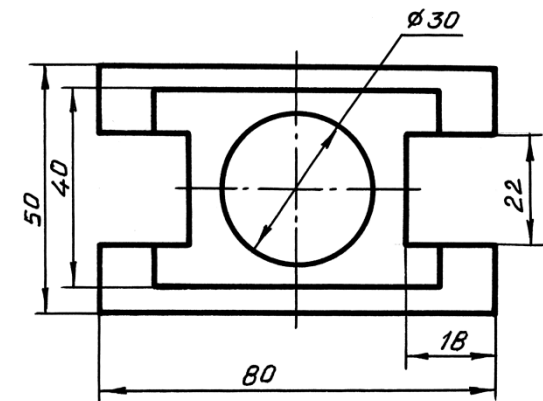
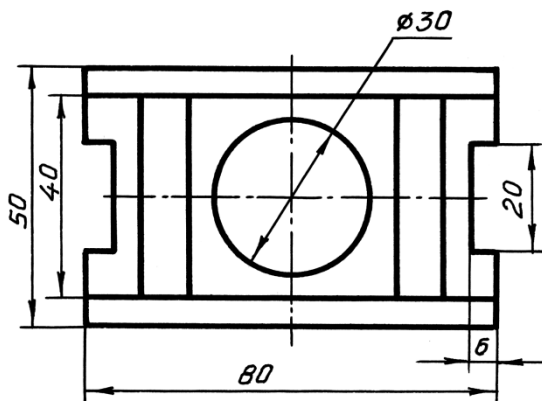
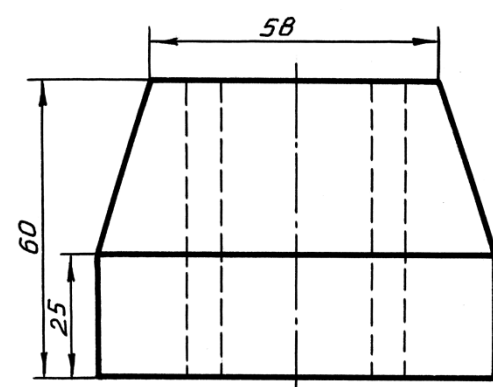

5-variant

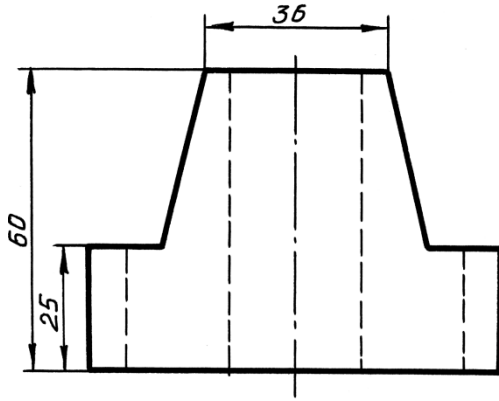

6-variant

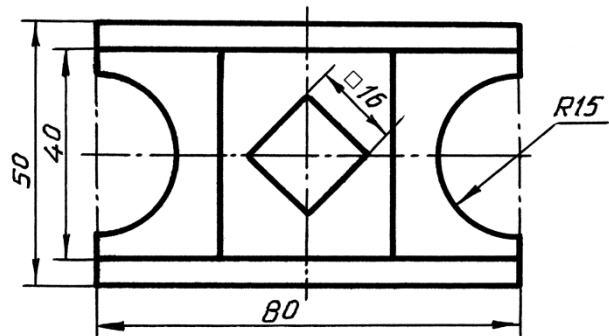
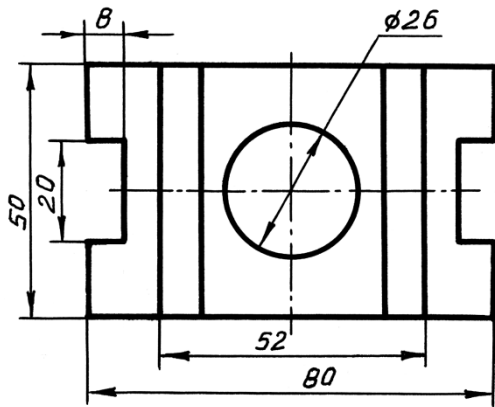
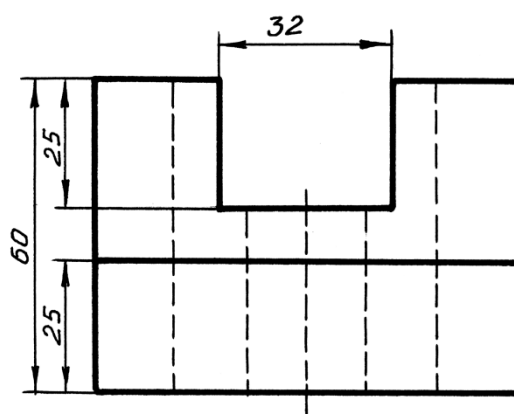

7-variant

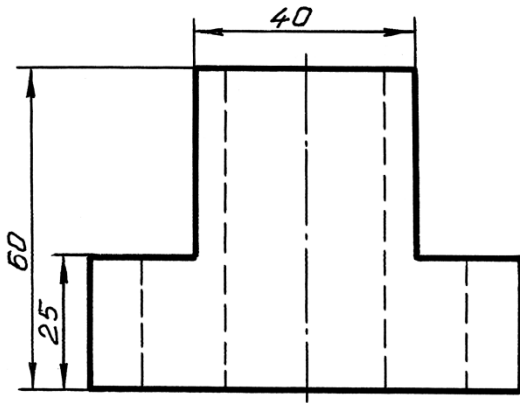

8-variant

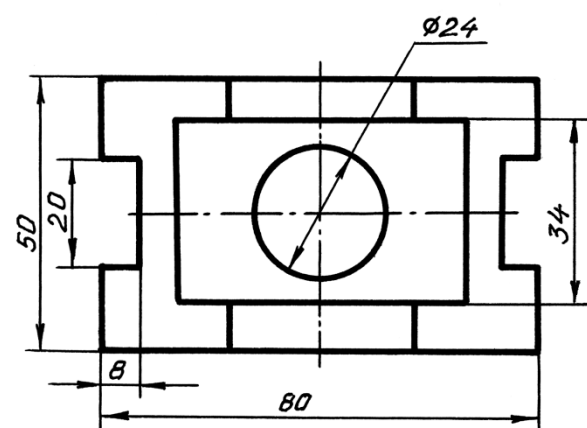
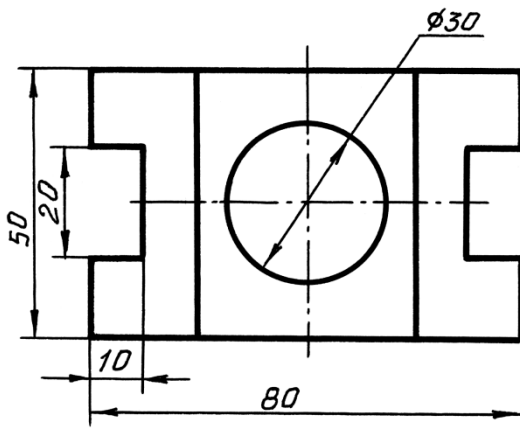
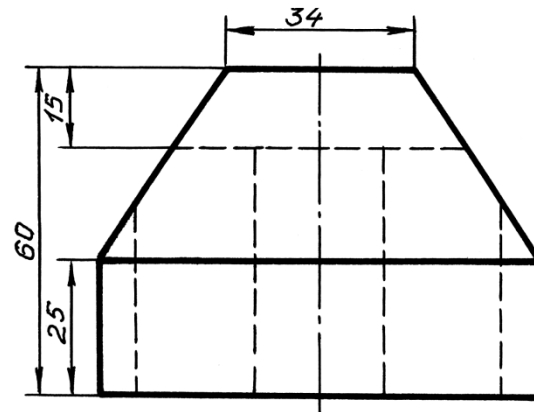

9-variant

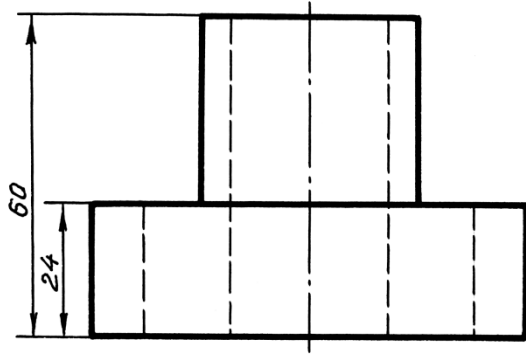

10-variant

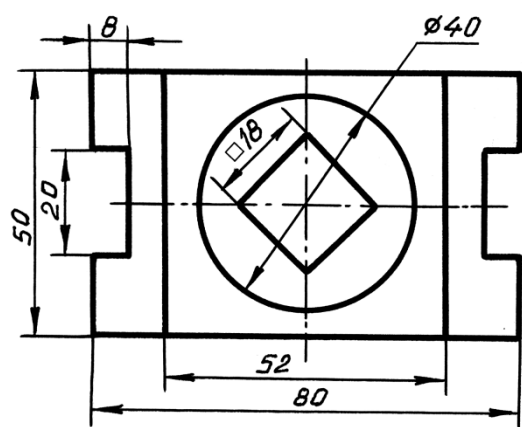
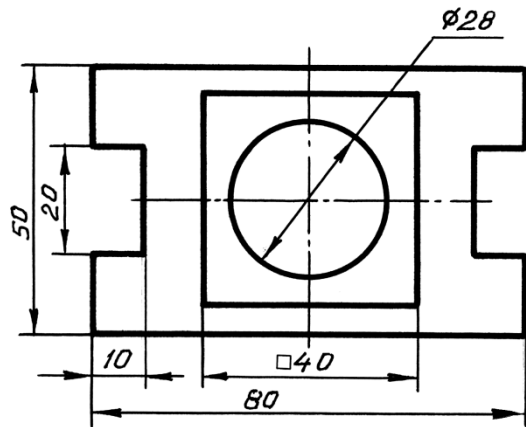
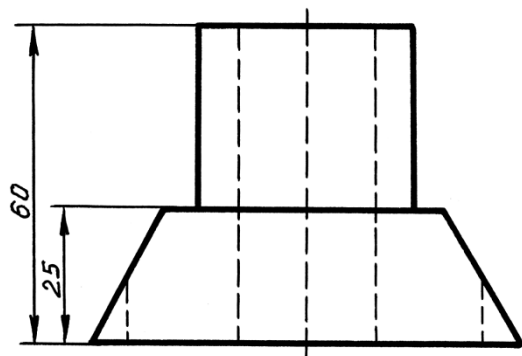

11-variant

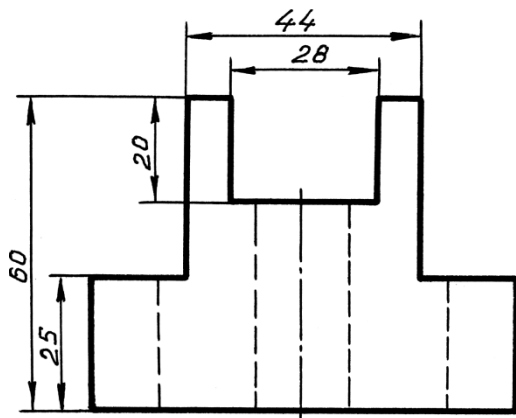

12-variant

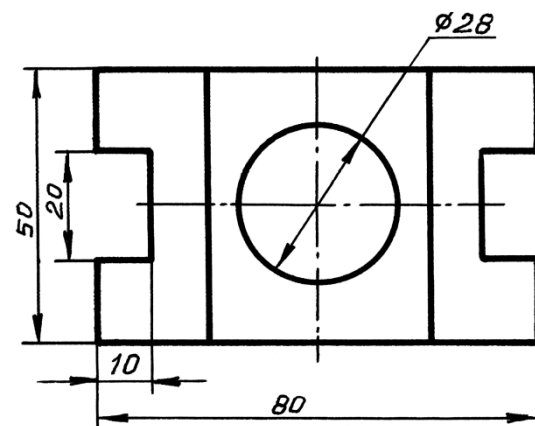
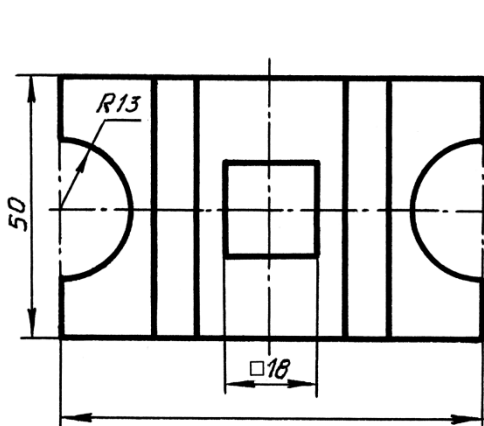
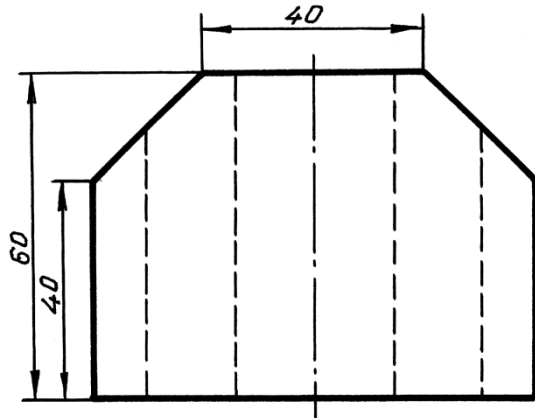

13-variant

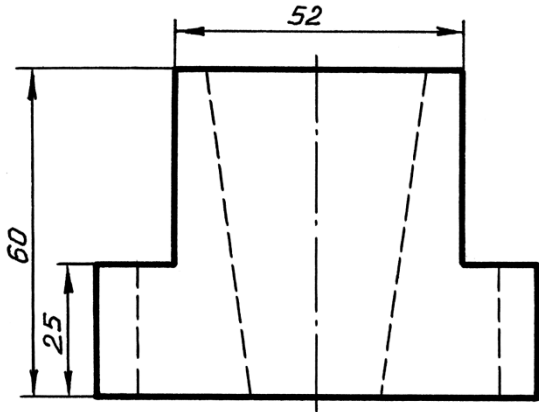

14-variant

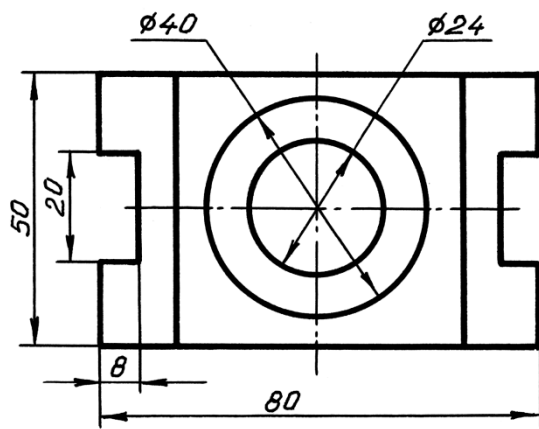
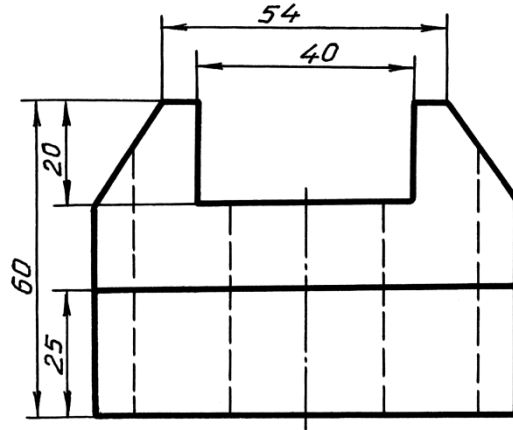

15-variant

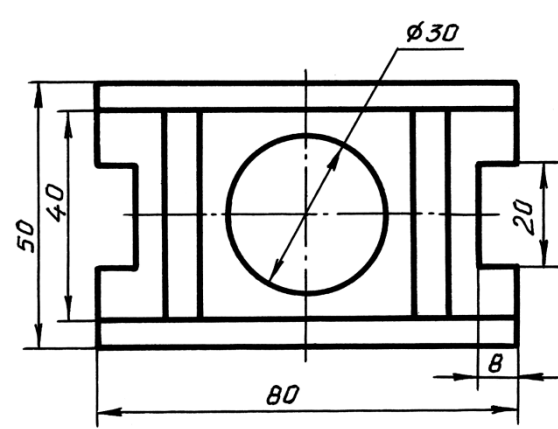

16-variant

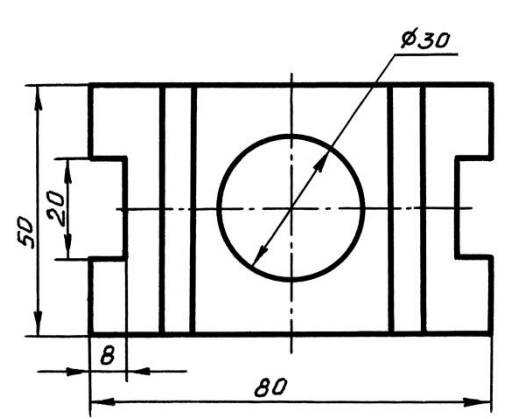
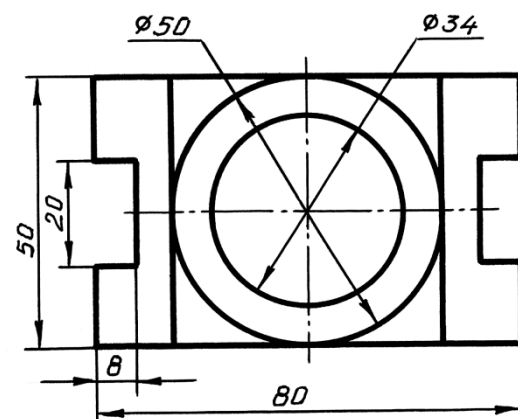
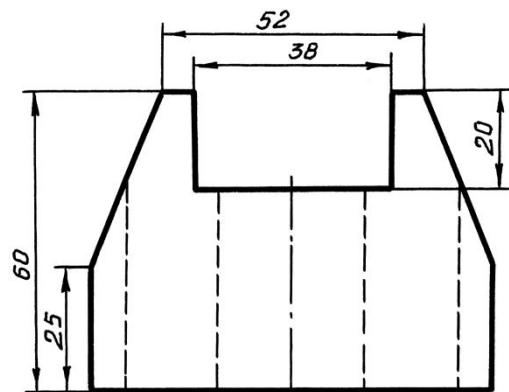
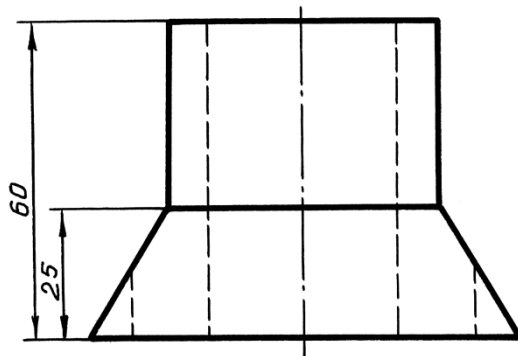

17-variant

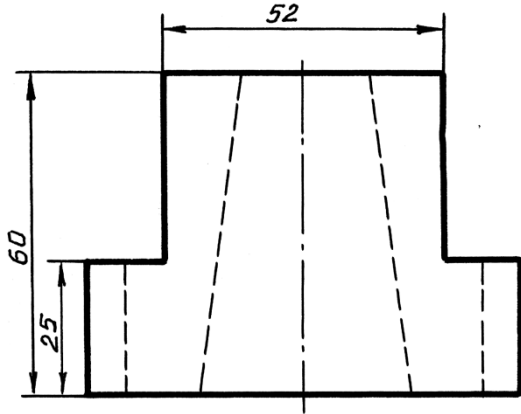

18-variant

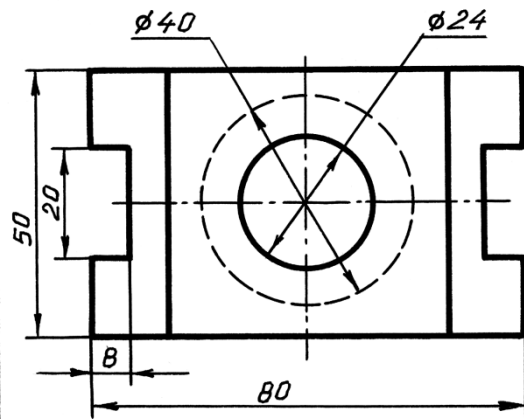
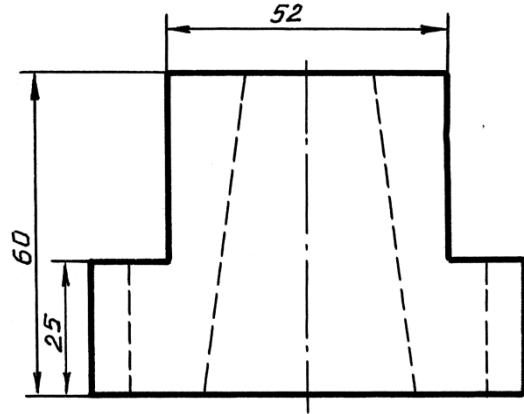

19-variant

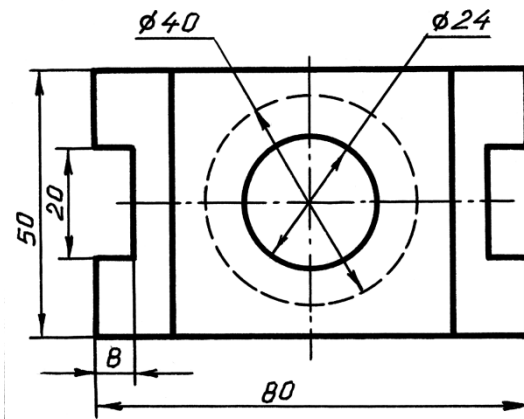

20-variant

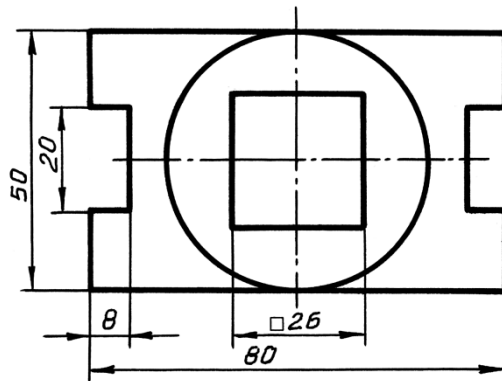
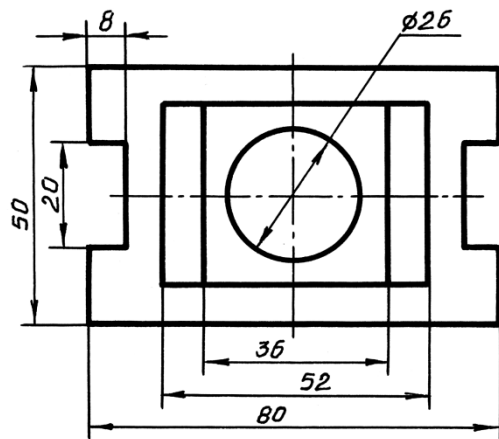
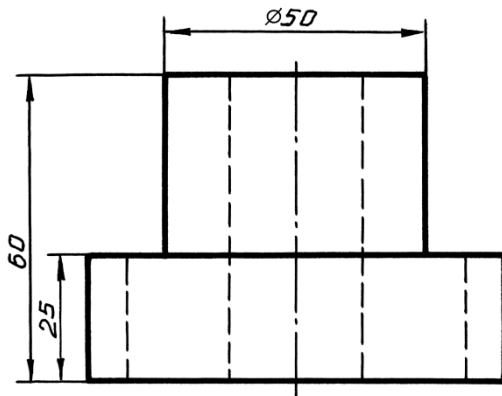
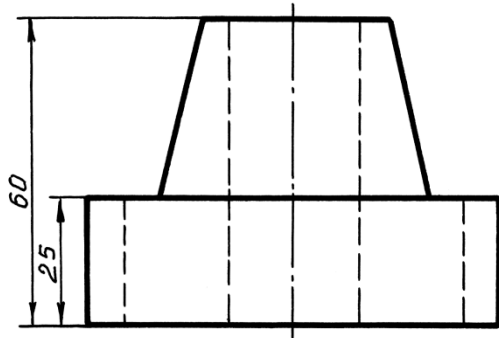

21-variant

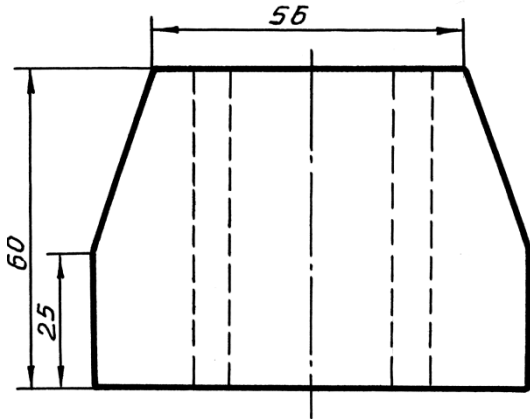

22-variant

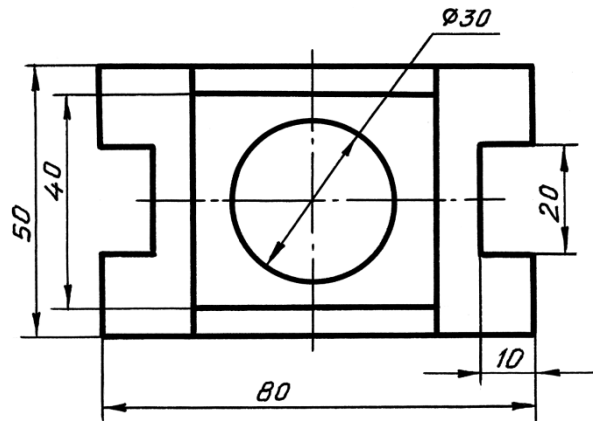
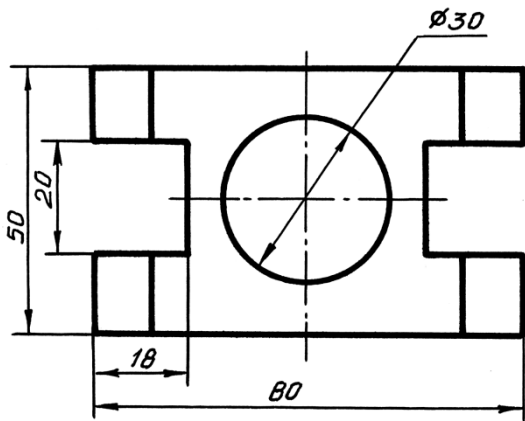
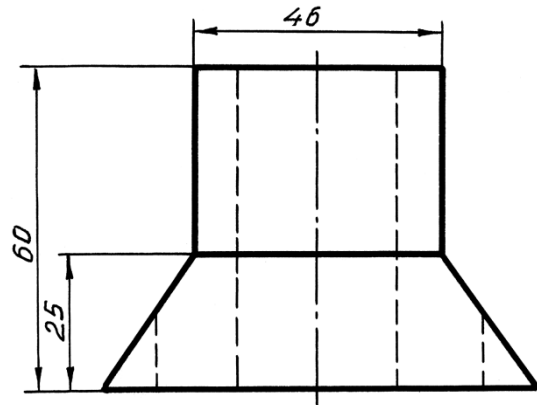

23-variant

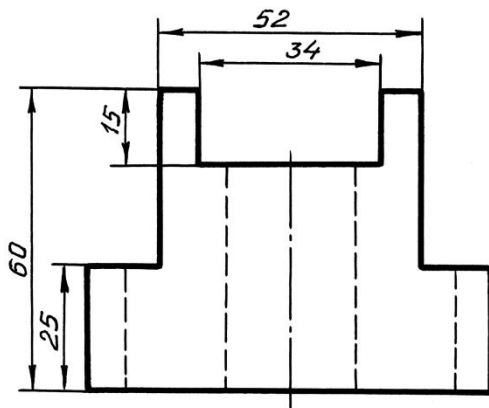

24-variant

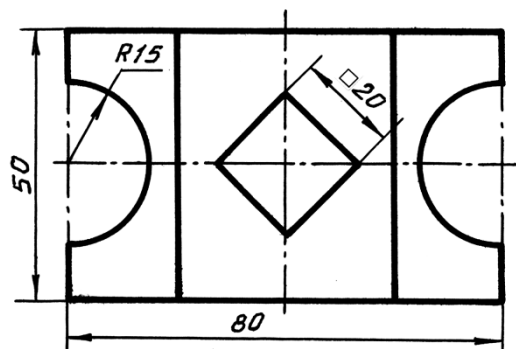
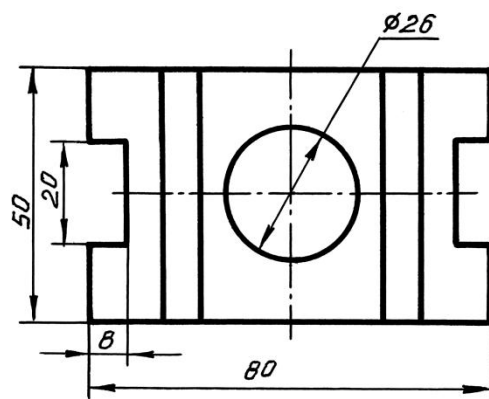
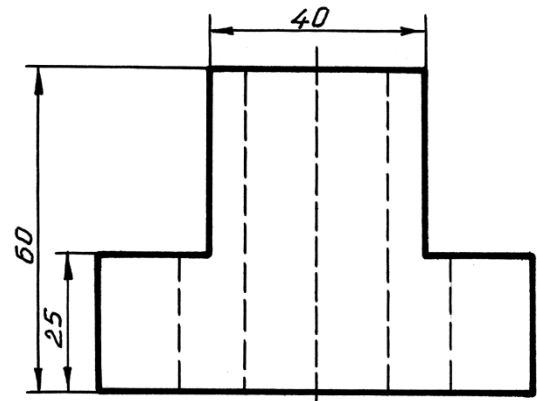

25-variant

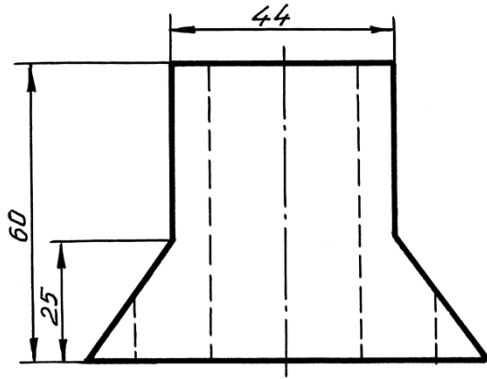

26-variant

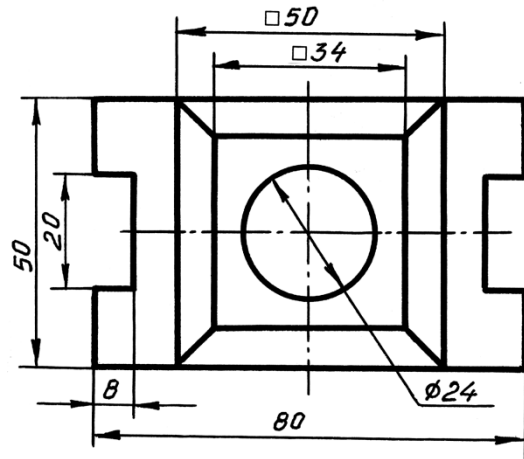
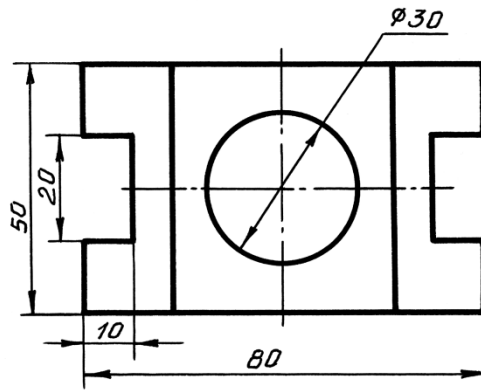
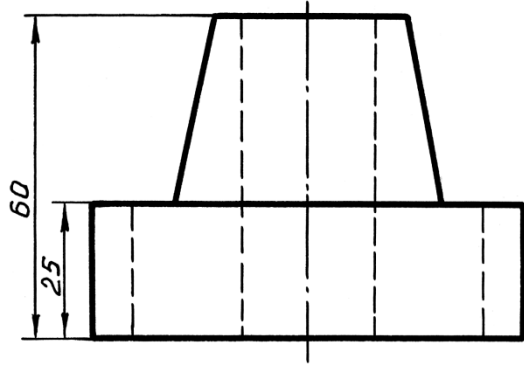

27-variant

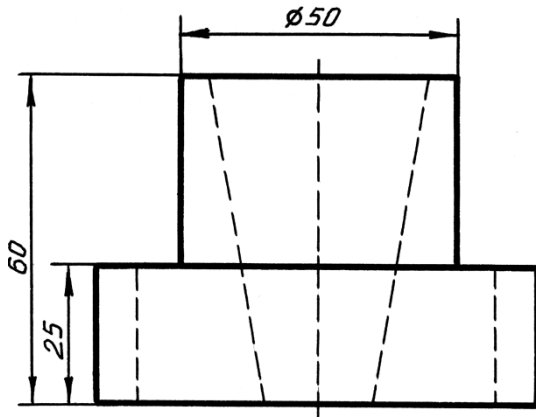

28-variant

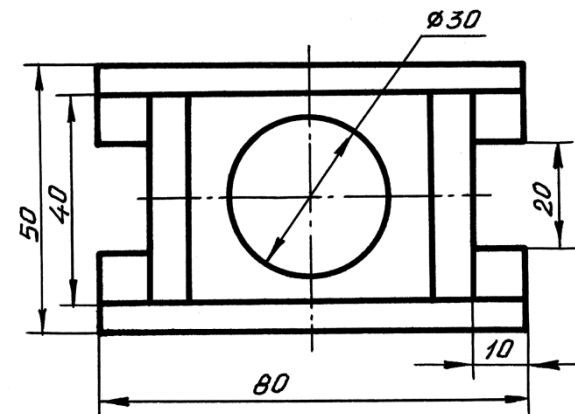
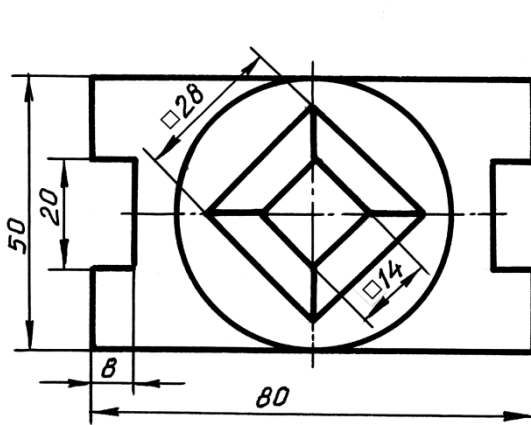
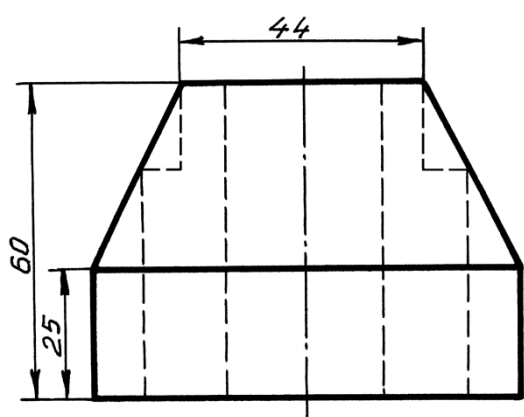

29-variant

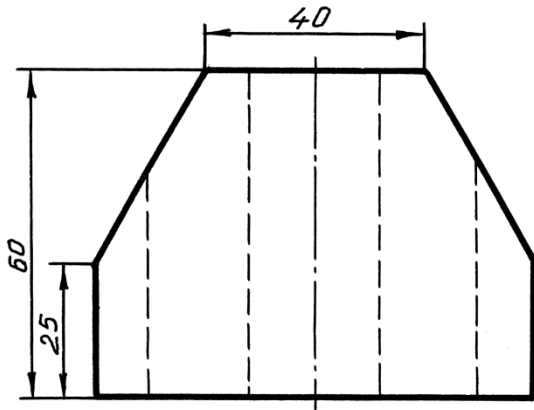

30-variant

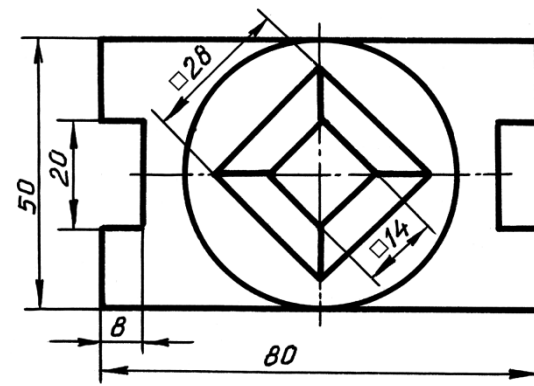
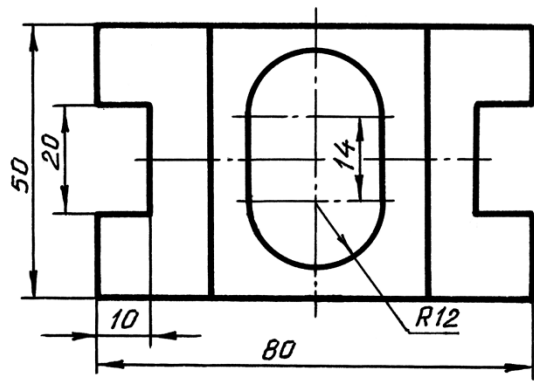
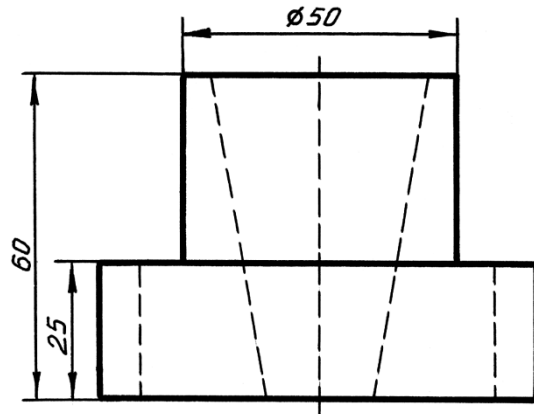

31-variant

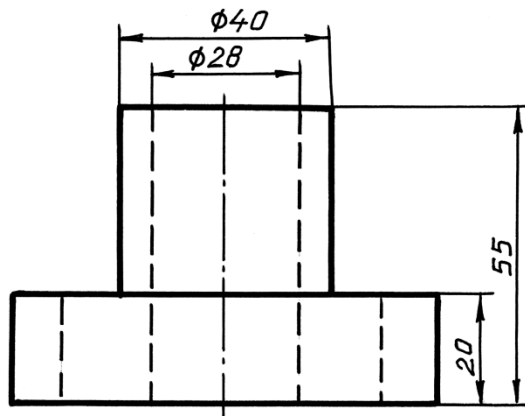

32-variant

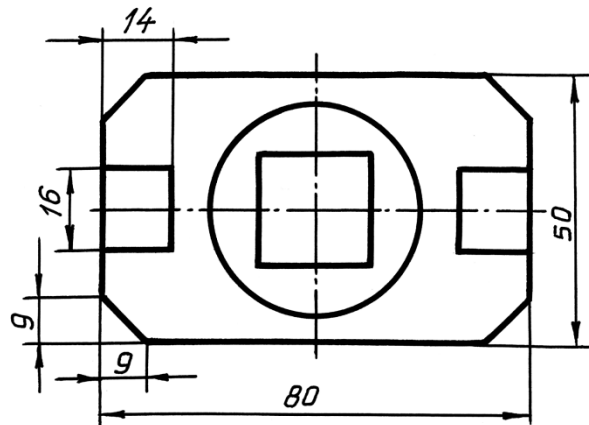
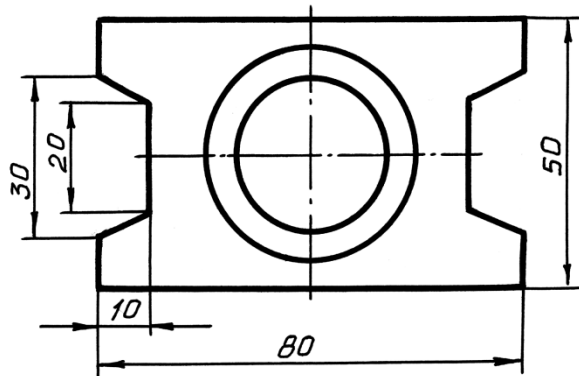
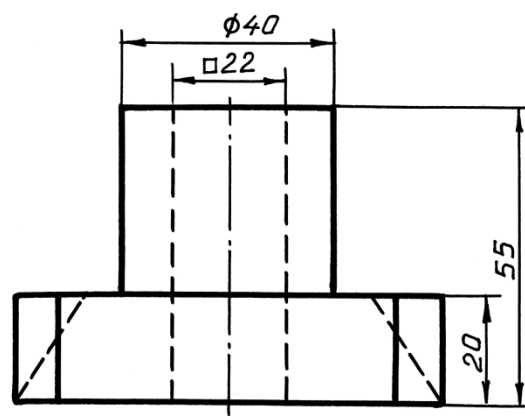

33-variant

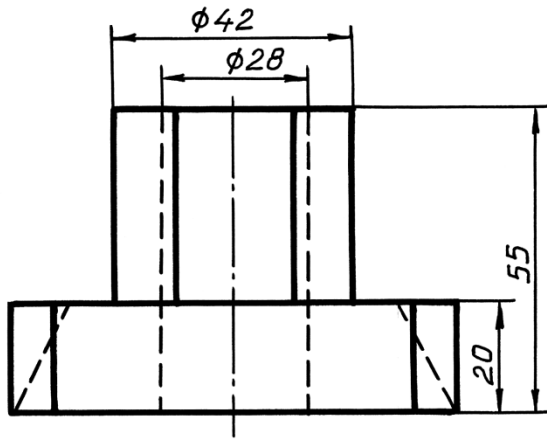

34-variant

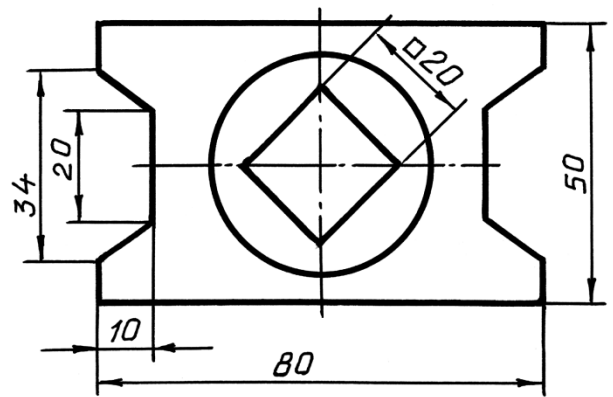
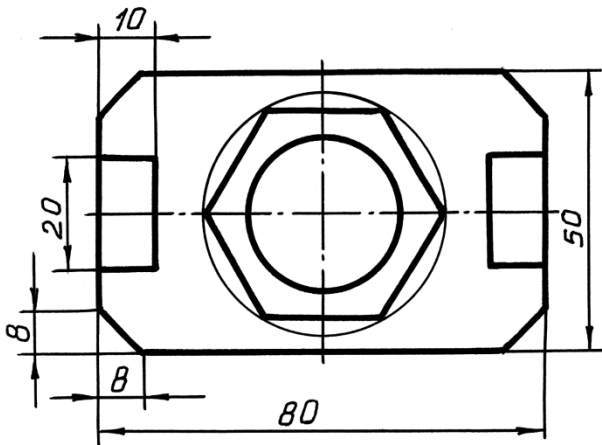
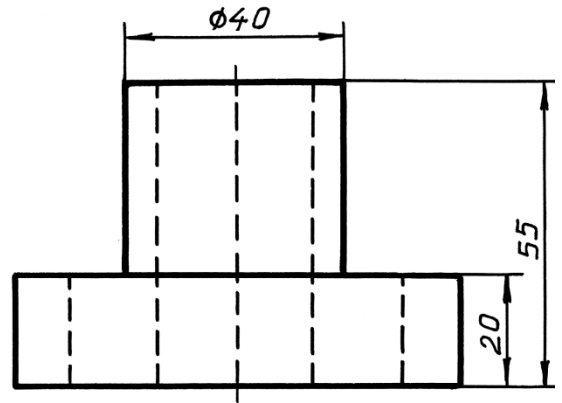

35-variant

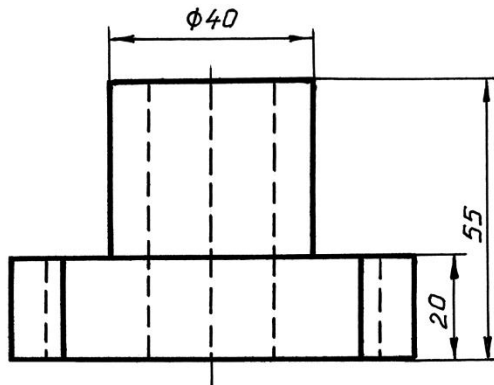

36-variant

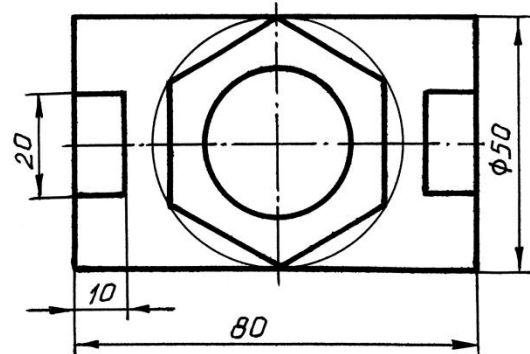
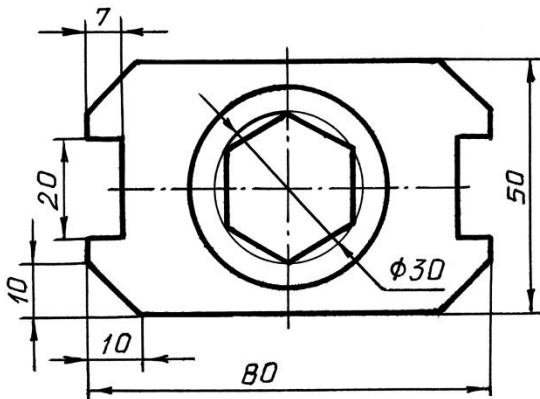
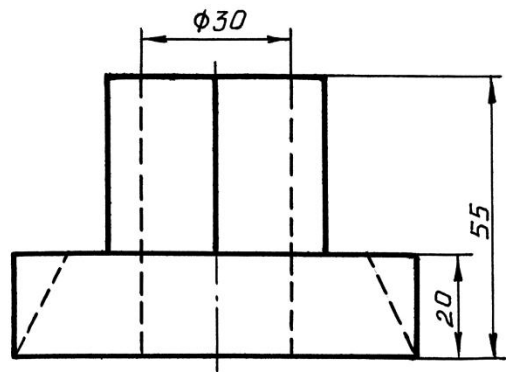

5,8-график ishlar varianti.

Variant-1

Фасад 1-4



Схема плана 1-20 этажа



Масштаб

1 0 1 2 3 4 5 6 7 8 9 10 м

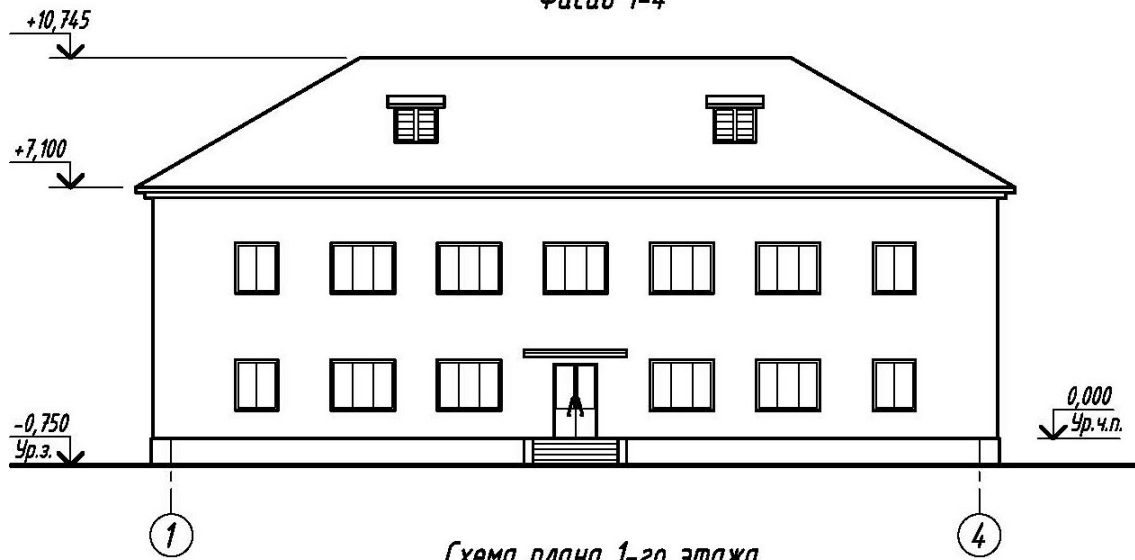
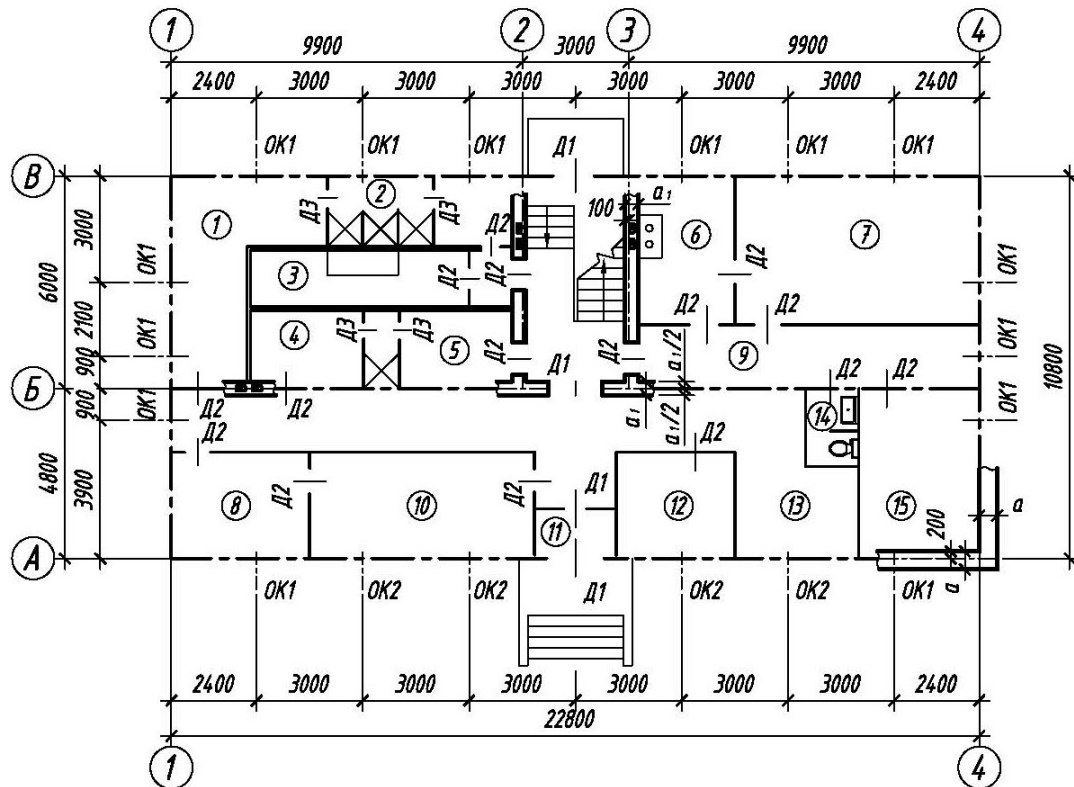

Ris. 3.8. Dom отдыха линейных бригад

Variant 1

Opisanie k zadaniyu: «Dom otдыха lineynykh brigad» (sm. ris. 3.8)

V zadanii dany shema plana pervogo etaja i fasad dvuxetajnogo zdaniya doma otдыха lineynykh brigad. Steny zdaniya kirpichnye: narujnye tolщиной v dva kirpicha, vnutrennie v poltora. Peregorodki iz shlakobetonnykh plit tolщиной 100 mm. V zadanii privedeny razмеры meжду osyami sten i proemov, pokazano razmещение lestnichnoy kletki, santexnicheskogo oborudovaniya, a takje privyazka sten zdaniya k koordinatsionnym osyam. Na sheme plana osi steny pokazany shtrixpunktirnymi liniyami, peregorodki – sploshnymi. Okonnyye proemy s chetvertuyami, pereplety s dvoynym ostekleniem. Dvernyye proemy: narujnye s chetvertuyami, vnutrennie bez chetvertey.

Oконные i dvernyye proemy oboznacheny: OK1, OK2, D1, D2, D3, a ix razмеры pod okonnyye i dvernyye bloki privedeny v spesifikatsiyax (tabl. 3.1, 3.2).

Tablitsa 3.1

Spesifikatsiya okonnykh proemov

Oboznachenie	Tip okonnykh blokov	Razмеры proema, mm	
		shirina b	высота h
OK1	Razdelnyy dvuxstvorchatyy	1210	1510
OK2	Razdelnyy trexstvorchatyy	1810	1510

Tablitsa 3.2

Spesifikatsiya dvernykh proemov

Oboznachenie	Tip dvernykh blokov	Razмеры proema, mm	
		shirina b	высота h
D1	Dvupolnyy derevyannyy	1210	2410
D2	Odnopolnyy derevyannyy	910	2110
D3	Odnopolnyy derevyannyy	760	2110

Razmещение peregorodok i nedostayuшcie razмеры chasteй zdaniya opredelyayutsya po cher-teju s pomoshchyu lineynogo masshtaba.

Na sheme plana pokazany pomesheniya pervogo etaja: 1 – garderob M, 2 – dush M, 3 – dezo-kamera, 4 – garderob J, 5 – dush J, 6 – kuxnya, 7 – komnata otдыха, 8 – sushilnoe otdelenie, 9 – koridor, 10 – prachechnaya, 11 – tambur, 12 – komnata personala, 13 – kamera xraneniya, 14 – tualet, 15 – belevaya.

V rabote trebuetsya:

1. Vyichertit plan pervogo etaja v masshtabe 1:100.
2. Na plane nanesti: tolщину sten i peregorodok, okonnyye i dvernyye proemy, lestnichnye marshi, pribory santexnicheskogo oborudovaniya, markirovku osey i proemov, postavit vnutrennie i narujnye razмеры, vyполnit markirovku pomesheniy i sostavit ix eksplikatsiyu, postavit ploщadi pomesheniy, высotные otmetki na vxode i otmetku pola pervogo etaja.

Variant-2

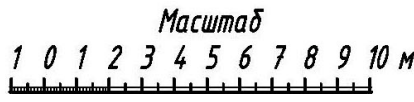
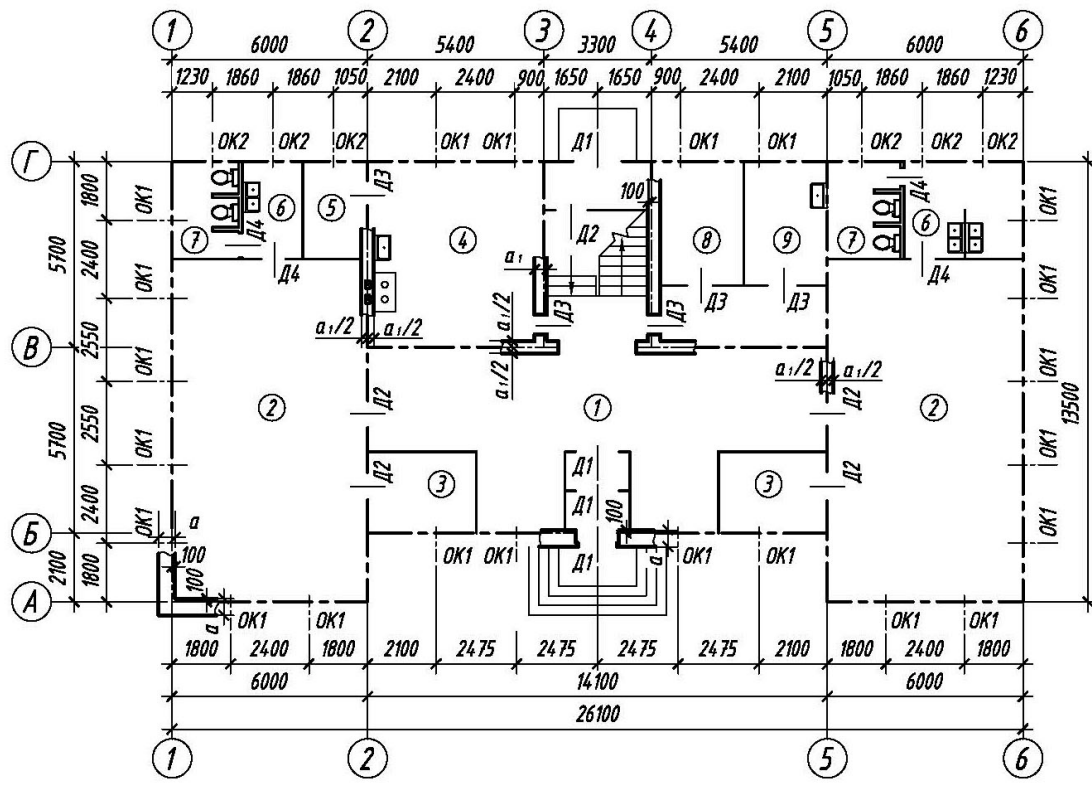
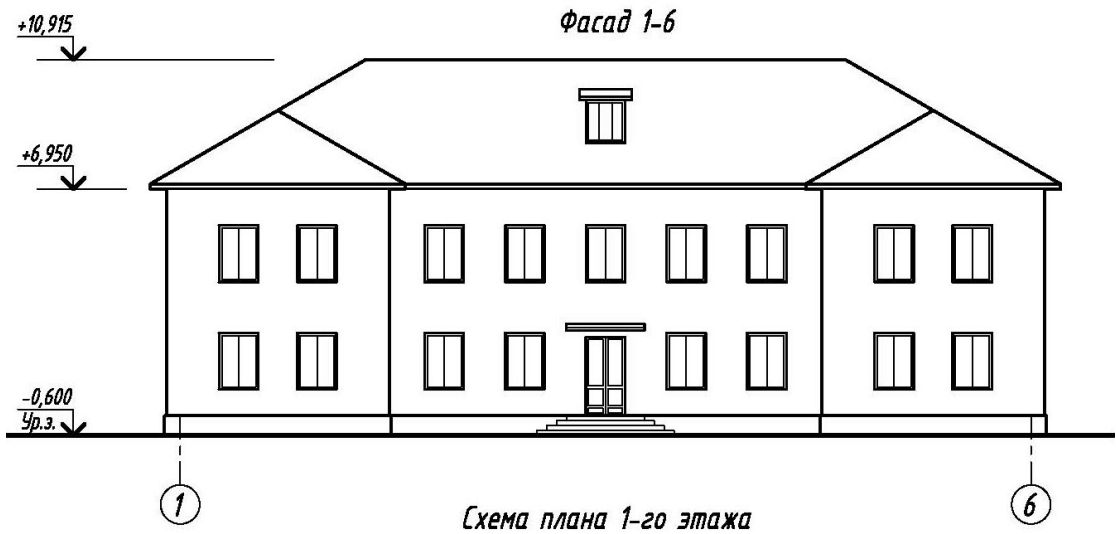

Ris.3.9.Detskiy sad

Variant 2

Opisanie k zadaniyu: «Detskiy sad» (sm. ris. 3.9)

V zadanii dany sxema plana pervogo etaja i fasad dvuxetajnogo zdaniya detskogo sada. Steny zdaniya kirpichnye: narujnye tolshinoy v dva kirpicha, vnutrennie – v poltora. Peregorodki iz shlakobetonnykh plit tolshinoy 100 mm. Zdanie oborudovano vodoprovodom, kanalizatsiey i sentralnym otopleniem. Okonnyye proemy s chetvertymi, pereplety s dvoynym ostekleniem. Dvernyye proemy: narujnye s chetvertymi, vnutrennie bez chetverty. Na sxeme plana ukazano razmeshenie santexnicheskogo oborudovaniya, kuxonnogo ochaga, ventilyatsionnykh i dymovykh kanalov; osi narujnykh i vnutrennykh kapitalnykh sten pokazany tolstyimi shtrixpunktirnyimi liniyami, peregorodki – sploshnymi. V zadanii pokazany razмеры meжду osyami sten, okonnymi i v ryade sluchaev dvernymi proemami, razmeshenie lestnichnoy kletki.

Okonnyye i dvernyye proemy oboznacheny: OK1, OK2, D1, D2 i t. d., a ix razмеры pod okonnyye i dvernyye bloki privedeny v spesifikatsiyax (tabl. 3.3, 3.4).

Tablitsa 3.3

Spesifikatsiya okonnykh proemov

Oboznachenie	Tip okonnykh blokov	Razмеры proema, mm	
		shirina b	высота h
OK1	Razdelnyy dvuxstvorchatyy	1210	1810
OK2	Razdelnyy trexstvorchatyy	910	1810

Tablitsa 3.4

Spesifikatsiya dvernnykh proemov

Oboznachenie	Tip dvernnykh blokov	Razмеры proema, mm	
		shirina b	высота h
D1	Dvupolnyy derevyannyy	1510	2410
D2	Dvupolnyy derevyannyy	1510	2110
D3	Odnopolnyy derevyannyy	910	2110
D4	Odnopolnyy derevyannyy	760	2110

Razmeshenie peregorodok i nedostayuushchie razмеры chastey zdaniya opredelyayutsya po cherteju s pomoshchyu lineynogo masshtaba.

Na sxeme plana pokazany pomesheniya pervogo etaja: 1 – vestibul s dvoynym tamburom, 2 – grupповые komnaty, 3 – krovatnyye komnaty, 4 – kuxnya, 5 – kladovaya, 6 – umyvalnyye, 7 – ubornyye, 8 – komnata zaveduyushchego, 9 – komnata vracha.

V rabote trebuetsya:

1. Vyichertit plan pervogo etaja v masshtabe 1:100.
2. Na plane nanesti: tolshinu sten i peregorodok, okonnyye i dvernyye proemy, lestnichnyye marshi, pribory santexnicheskogo oborudovaniya, markirovku osey i proemov, razмеры, naimenovanie pomesheniya i ix ploshchadi, vysotnyye otmetki na vxode i otmetku pola pervogo etaja.

Вариант 2

Фасад 1-4



Схема плана 1-го этажа



Масштаб

1 0 1 2 3 4 5 6 7 8 9 10 м

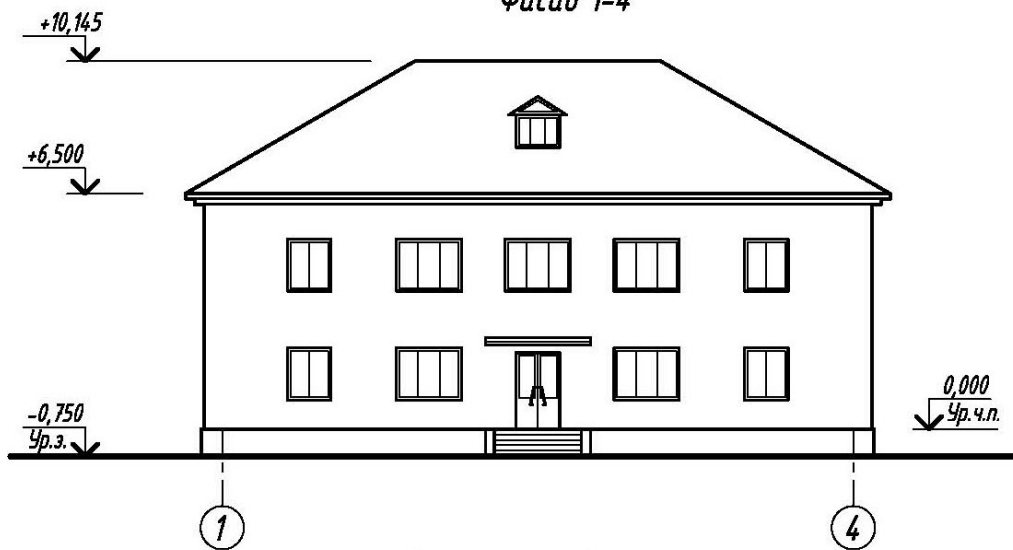
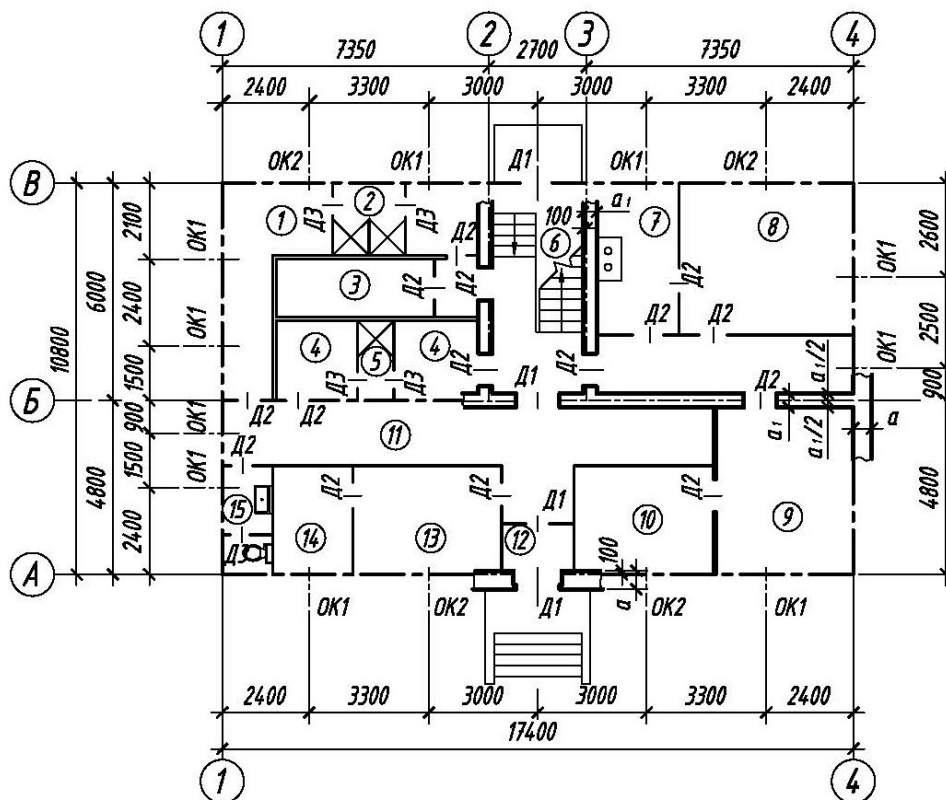
Ris. 3.10. Дом связи

Variant 2

Opisanie k zadaniyu: «Dom svyazi» (sm. ris. 3.10)

V zadanii dany shema plana pervogo etaja i fasad dvuxetajnog doma otдыха loko-
motivnykh brigad. Steny zdaniya kirpichnye: narujnye tolщinoy v dva kirpicha, vnutren-
nie v poltora. Peregorodki iz shlakobetonnykh plit tolщinoy 100 mm.

Na sxeme plana zdaniya privedeny razмеры mejdu osyami sten i proemov, pokazano
razmещение lestnichnoy kletki, santexnicheskogo oborudovaniya, a takje privyazka sten zda-
niya k koordinatsionnym osyam. Osi sten pokazany utolщennymi shtrixpunktirnymi lini-
yami, peregorodki – sploshnymi. Okonnye proemy s chetvertyami, pereplety s dvoynym ostekleniem.
Dvernye proemy: narujnye s chetvertyami, vnutrennie bez chetvertey. Okon-
nye i dvernye proemy oboznachenы: OK1, OK2, D1, D2, D3, a ix razмеры pod okonnye i dvernye bloki
privedeny v spesifikatsiyax (tabl. 3.5, 3.6).

Tablitsa 3.5

Spesifikatsiya okonnykh proemov

Obozna- chenie	Tip okonnykh blokov	Razмеры proema, mm	
		shirina b	высота h
OK1	Razdelnyy dvuxstvorchatyy	1210	1510
OK2	Razdelnyy trexstvorchatyy	1810	1510

Tablitsa 3.6

Spesifikatsiya dvernykh proemov

Obozna- chenie	Tip dvernykh blokov	Razмеры proema, mm	
		shirina b	высота h
D1	Dvupolnyy derevyannyy	1210	2110
D2	Odnopolnyy derevyannyy	910	2110
D3	Odnopolnyy derevyannyy	610	2110

Razmещение peregorodok i nedostayuщие razмеры chastey zdaniya opredelyayutsya po
cher- teju v sootvetstvii s lineynym masshtabom.

Na sxeme plana zdaniya privedena planirovka pomещeniy pervogo etaja: 1 – garde-
rob M, 2 – dush M, 3 – dezokamera, 4 – garderob J, 5 – dush J, 6 – lestnitsa, 7 – kuxnya, 8 –
komnata otдыха, 9 – sushilnoe otdelenie, 10 – prachechnaya, 11 – koridor, 12 – tambur, 13 –
naryadchik, 14 – komnata xraneniya veshy, 15 – tualet.

V rabote trebuetsya:

1. Vyichertit plan pervogo etaja v masshtabe 1:100.
2. Na plane nanesti: tolщину sten i peregorodok, vnutrennie razмеры pomещeniy v svetu,
privyazku dvernykh proemov, narujnye razмеры zdaniya (prostenki i proemy), pri-
vyazki kapitalnykh sten, okonnye i dvernye proemy, lestnichnye marshi, pribory sanitar-
no-
texnicheskogo oborudovaniya, markirovku osey i proemov, ukazat naimenovanie pome-
sheniy i ix
ploщadi, vyсотные otmetki na vxode i otmetku pola pervogo etaja.

Вариант 3

Фасад 1-4



Схема плана 1-го этажа



Масштаб

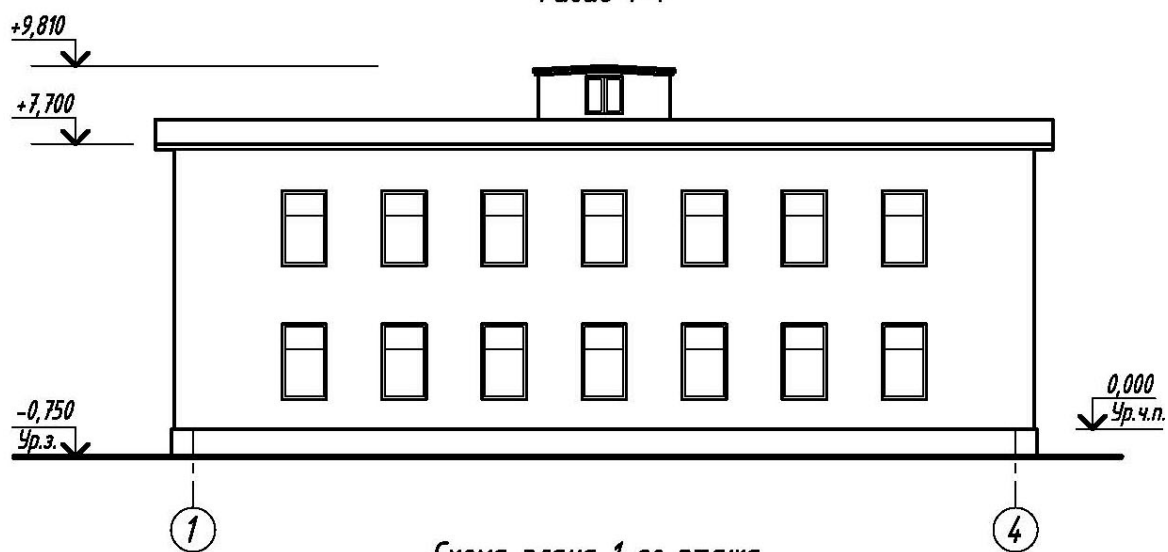
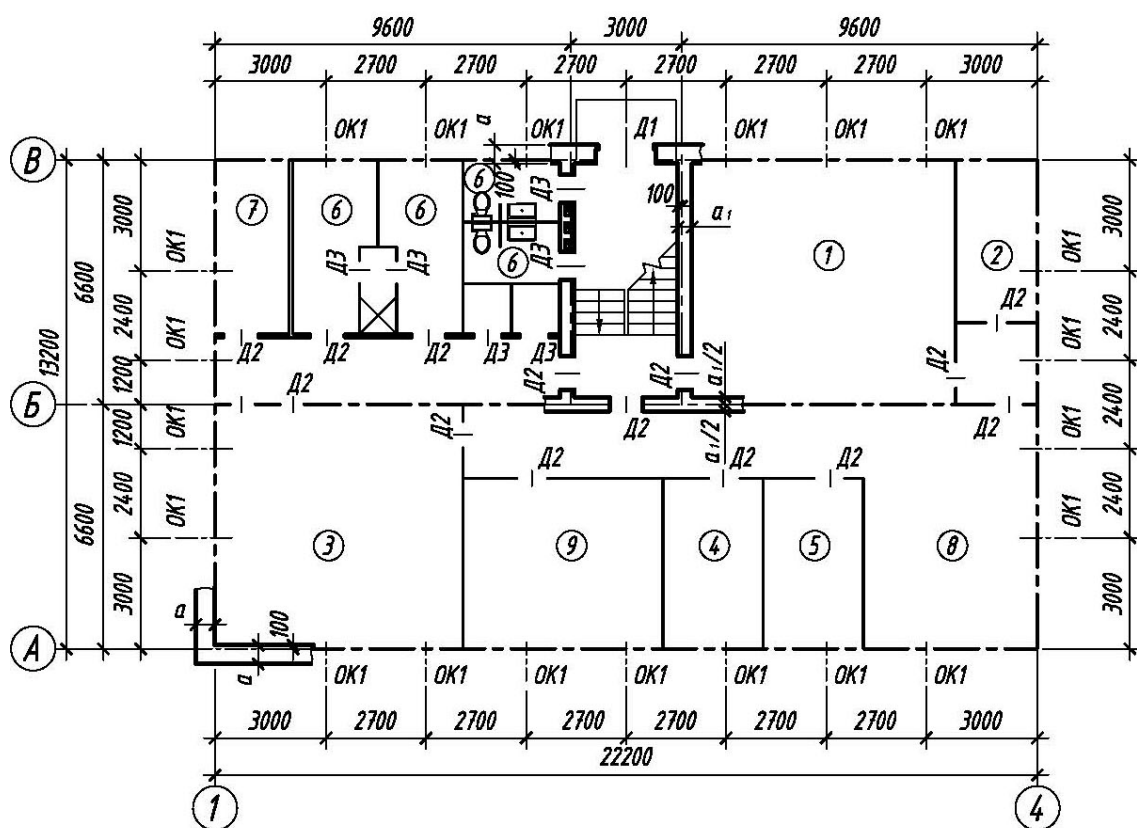
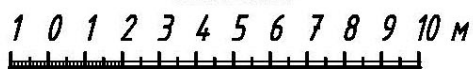

Ris. 3.11. Дом связи

Variant 3

Opisanie k zadaniyu: «Dom svyazi» (sm. ris. 3.11)

V zadanii dany: sxema plana pervogo etaja i fasad dvuxetajnog zdanija doma svyazi. Steny zdanija kirpichnye: naryjnye tolщinoy v dva kirpicha, vnutrennie – v poltora. Peregorodki iz gipsobetonnykh плит толщिनой 100 mm. Zdanie imeet vodoprovod, kanalizatsiyu, sentralnoe otoplenie. Na sxeme plana ukazany razмеры meждy osyami sten i proemov, дано размещение ventilyatsionnykh kanalov, lestnichnoy kletki, a takje privyazka sten zdanija k koordinatsionnym osyam; osi sten pokazany shtrixpunktirnymi liniyami, peregorodki – sploshnymi. Okonnyye proemy s chetvertymi, pereplety s dvoynym ostekleniem. Dvernyye proemy: naryjnye s chetvertymi, vnutrennie bez chetvertey.

Okonnyye i dvernyye proemy oboznacheny: OK1, D1, D2 i t. d., a ix razмеры pod okonnyye i dvernyye bloki privedeny v spesifikatsiyax (tabl. 3.7, 3.8).

Tablitsa 3.7

Spesifikatsiya okonnykh proemov

Oboznachenie	Tip okonnykh blokov	Razмеры proema, mm	
		shirina b	высота h
OK1	Razdelnyy odnostvorchatyy	1210	2110

Tablitsa 3.8

Spesifikatsiya dvernykh proemov

Oboznachenie	Tip dvernykh blokov	Razмеры proema, mm	
		shirina b	высота h
D1	Dvupolnyy derevyannyy	1510	2410
D2	Dvupolnyy derevyannyy	1510	2110
D3	Odnopolnyy derevyannyy	910	2110
D4	Odnopolnyy derevyannyy	760	2110

Razmeshenie peregorodok i nedostayuщie razмеры chastey zdanija opredelyayutsya po cherteжу v sootvetstviy s lineynym masshtabom.

Na sxeme plana pokazany pomesheniya pervogo etaja: 1 – zal apparatov Morze; 2 – ventkamera; 3 – blokstansiya; 4 – akkumulyatornaya; 5 – kislotnaya; 6 – dushevyye i tualety (mujskie i jenskie); 7 – sklad; 8 – garderob; 9 – masterskie.

V rabote trebuetsya:

1. Vychertit plan pervogo etaja v masshtabe 1:100.
2. Na plane nanesti: толщину sten, peregorodok, okonnyye i dvernyye proemy, lestnichnyye marshi, pribory sanitarno-texnicheskogo oborudovaniya, markirovku osey i proemov, ukazat naimenovanie pomesheniya i ix ploщadi, высотные otmetki na vxode i otmetku pola pervogo etaja.

Вариант 4

Фасад 1-6



Схема плана 1-го этажа



Масштаб

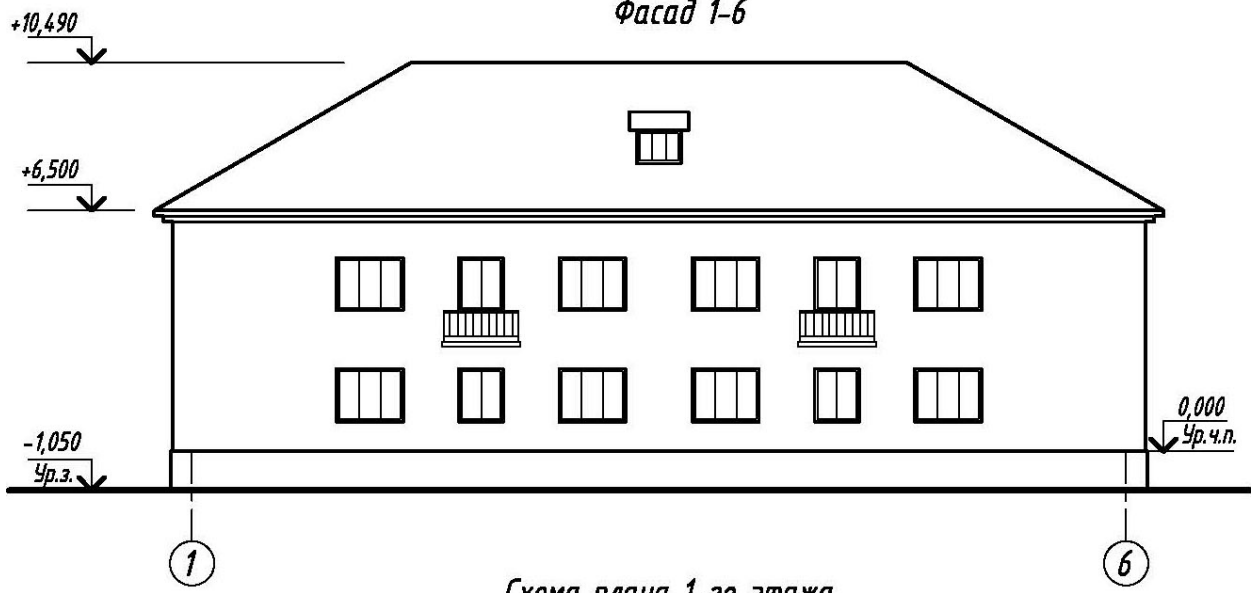
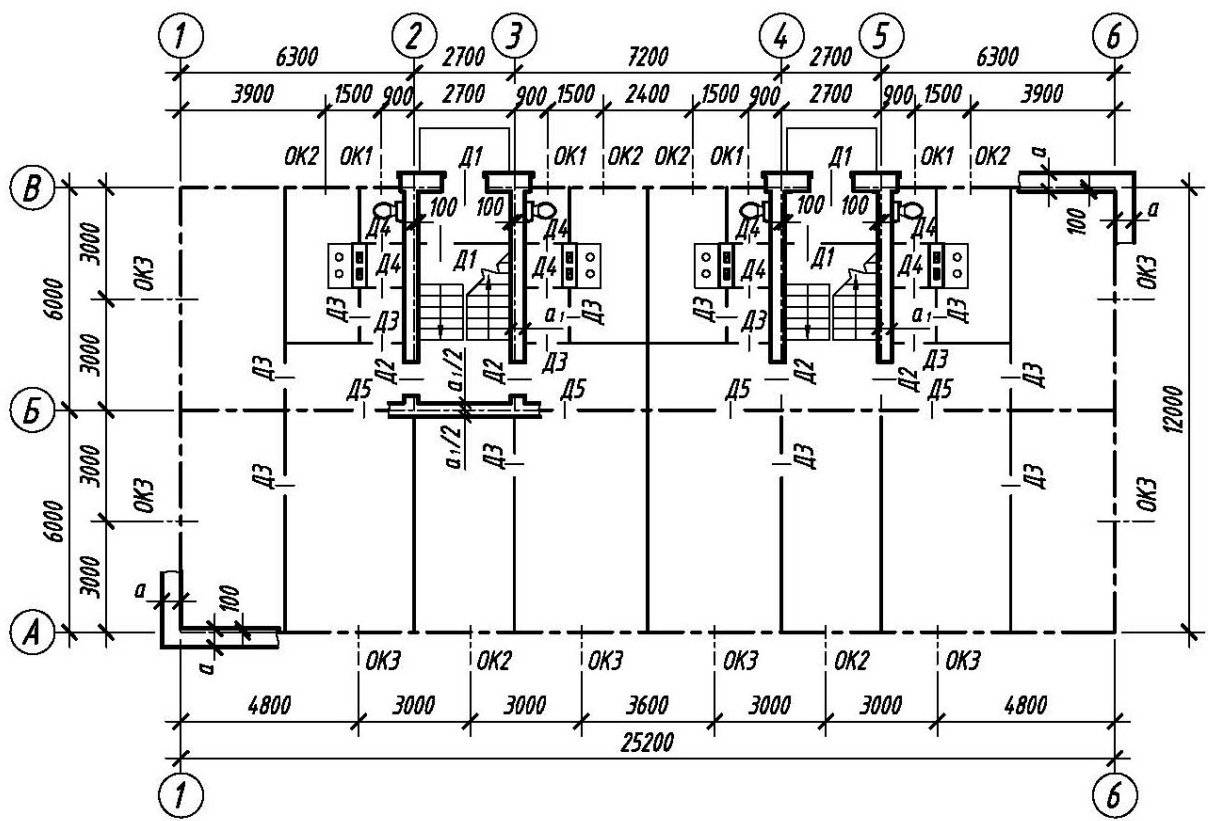
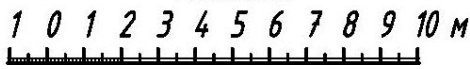

Ris. 3.12. Jiloy dom na 8 kvartir

Variant 4

Opisanie k zadaniyu: «Jiloy dom na 8 kvartir» (sm. ris. 3.12)

V zadanii dany: sxema plana pervogo etaja i fasad dvuxetajnogo jilogo doma. Ste-ny zdaniya kirpichnye: narujnye tolщиной v dva kirpicha, vnutrennie – v poltora. iz shla-kobetonnykh plit tolщиной 100 mm.

Na sxeme plana zdaniya privedeny razмеры mejdu osyami sten i proemov, pokazano razmeshenie pechey, ventilyatsionnykh i dымовых kanalov, lestnichnoy kletki, a takje pri-vyazka sten zdaniya k koordinatsionnyim osyam. Osi sten pokazany utolщennymi shtrixpunktirnymi liniyami, peregorodki – sploshnymi. Okonnyye proemy s chetvertuyami, pereplety s dvoynym ostekleniem. Dvernyye proemy: narujnye s chetvertuyami, vnutrennie bez chetvertuy. Okonnyye i dvernyye proemy oznacheny: OK1, OK2, OK3, D1, D2, i t. d., a ix razмеры pod okonnyye i dvernyye bloki privedeny v spesifikatsiyax (tabl. 3.9, 3.10).

Tablitsa 3.9

Spesifikatsiya okonnykh proemov

Obozna-chenie	Tip okonnykh blokov	Razмеры proema, mm	
		shirina b	высота h
OK1	Razdelnyy dvuxstvorchatyy	910	1510
OK2	Razdelnyy dvuxstvorchatyy	1210	1510
OK3	Razdelnyy trexstvorchatyy	1810	1510

Tablitsa 3.10

Spesifikatsiya dvernykh proemov

Obozna-chenie	Tip dvernykh blokov	Razмеры proema, mm	
		shirina b	высота h
D1	Dvupolnyy derevyanny	1210	2110
D2	Odnopolnyy derevyanny	910	2110
D3	Odnopolnyy derevyanny	910	2110
D4	Odnopolnyy derevyanny	760	2110
D5	Dvupolnyy osteklenny	1210	2110

Razmeshenie peregorodok i nedostayushchie razмеры chastey zdaniya opredelyayutsya po chertezu v sootvetstvii s lineynym masshtabom.

Na sxeme plana zdaniya privedena planirovka pomesheniy pervogo etaja.

V rabote trebuetsya:

1. Vyichertit plan pervogo etaja v masshtabe 1:100.
2. Na plane nanesti: толщину sten i peregorodok, vnutrennie razмеры pomesheniy v svetu, privyazku dvernykh proemov, narujnye razмеры zdaniya (prostenki i proemy), pri-vyazki kapitalnykh sten, okonnyye i dvernyye proemy, lestnichnyye marshi, pribory sanitarnotekhnicheskogo oborudovaniya, markirovku osey i proemov, ukazat naimenovanie pomesheniy i ix ploщadi, vyсотные otmetki na vxode i otmetku pola pervogo etaja.

Вариант 5

Фасад 1-4



Схема плана 1-го этажа



Масштаб

1 0 1 2 3 4 5 6 7 8 9 10 м

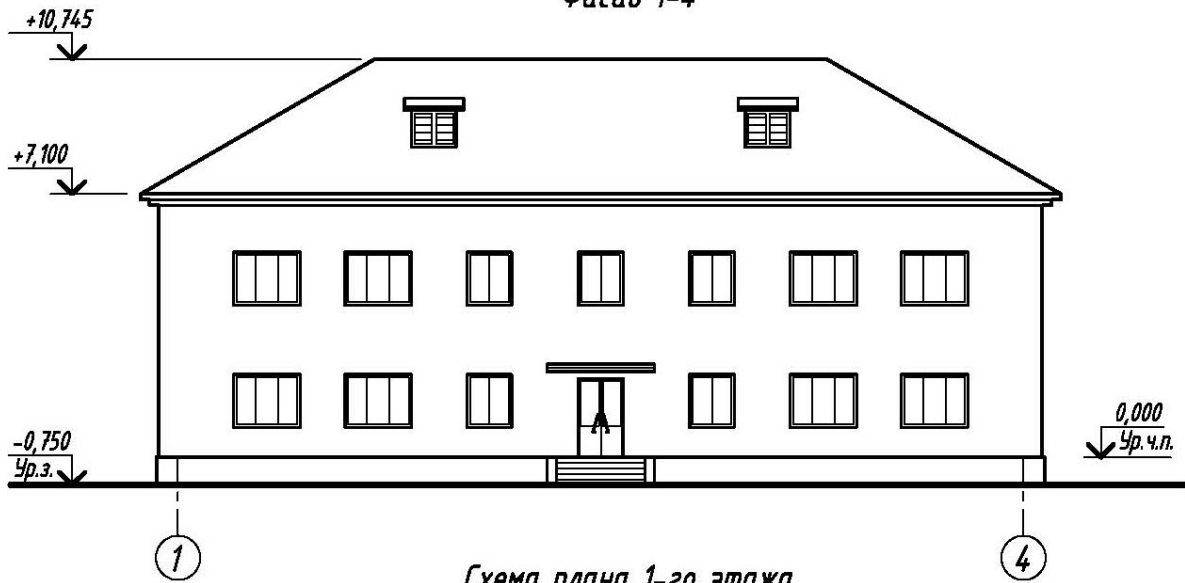
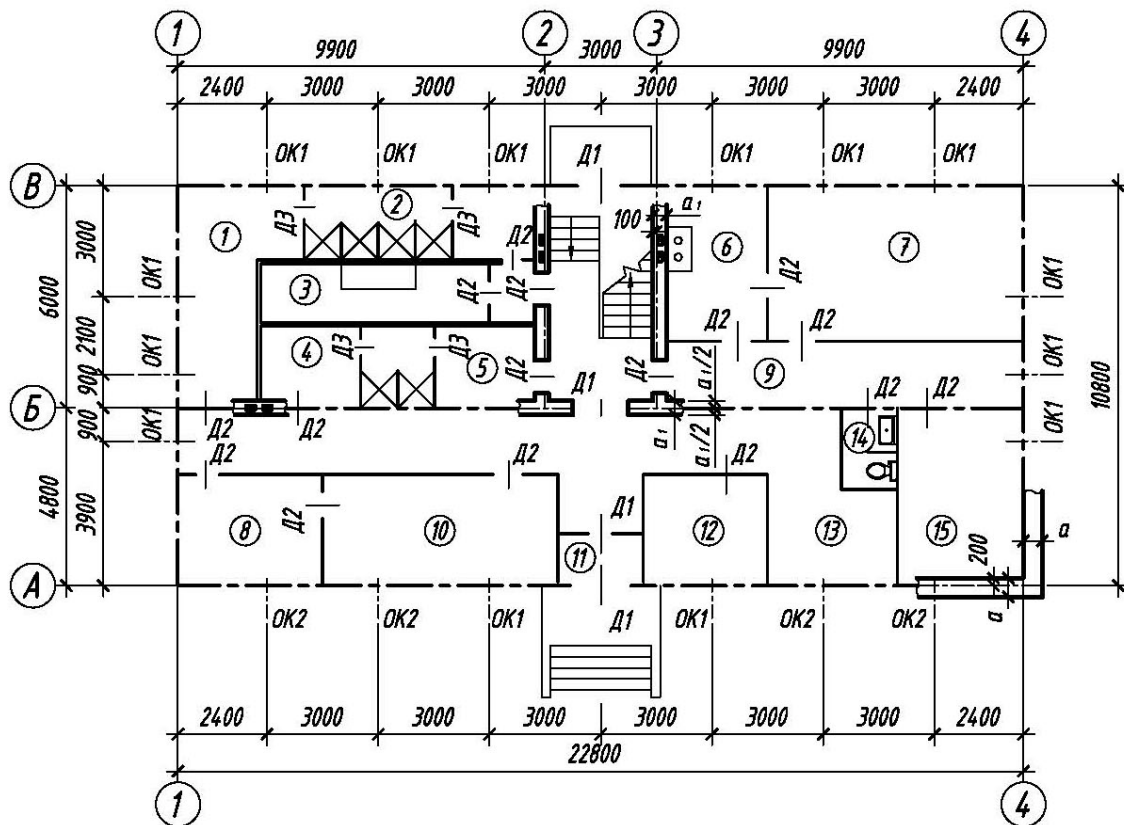
Ris. 3.13. Дом отдыха линейных бригад

Variant 5

Opisanie k zadaniyu: «Dom otдыха lineynykh brigad» (sm. ris. 3.13)

V zadanii dany shema plana pervogo etaja i fasad dvuxetajnogo zdaniya doma otдыха lineynykh brigad. Steny zdaniya kirpichnye: narujnye tolщиной v dva s polovinoй kirpicha, vnutrennie v poltora. Peregorodki iz kirpicha tolщиной 120 mm. V zadanii privedeny razмеры meјdu osyami sten i proemov, pokazano razmещenie lestnichnoy kletki, santexnicheskogo oborudovaniya, a takje privyazka sten zdaniya k koordinatsionnym osyam. Na sheme plana osi steny pokazany shtrixpunktirnymi liniyami, peregorodki – sploshnymi. Okonnye proemy s chetvertymi, pereplety s dvoynym ostekleniem. Dvernye proemy: narujnye s chetvertymi, vnutrennie bez chetvertей.

Okonnye i dvernye proemy oboznacheny: OK1, OK2, D1, D2, D3, a ix razмеры pod okonnye i dvernye bloki privedeny v spesifikatsiyax (tabl. 3.11, 3.12).

Tablitsa 3.11

Spesifikatsiya okonnykh proemov

Oboznachenie	Tip okonnykh blokov	Razмеры proema, mm	
		shirina <i>b</i>	высота <i>h</i>
OK1	Razdelny dvuxstvorchaty	1210	1510
OK2	Razdelny trexstvorchaty	1810	1510

Tablitsa 3.12

Spesifikatsiya dvernykh proemov

Oboznachenie	Tip dvernykh blokov	Razмеры proema, mm	
		shirina <i>b</i>	высота <i>h</i>
D1	Dvupolny derevyanny	1210	2410
D2	Odnopolny derevyanny	910	2110
D3	Odnopolny derevyanny	760	2110

Razmещenie peregorodok i nedostayuщie razмеры chastey zdaniya opredelyayutsya po cher-teju s pomoshчу lineynogo masshtaba.

Na sheme plana pokazany pomesheniya pervogo etaja: 1 – garderob M, 2 – dush M, 3 – dezo-kamera, 4 – garderob J, 5 – dush J, 6 – kuxnya, 7 – komnata otдыха, 8 – sushilnoe otdelenie, 9 – koridor, 10 – prachechnaya, 11 – tambur, 12 – komnata personala, 13 – kamera xraneniya, 14 – tualet, 15 – belevaya.

V rabote trebuetsya:

1. Vychertit plan pervogo etaja v masshtabe 1:100.
2. Na plane nanesti: tolщину sten i peregorodok, okonnye i dvernye proemy, lestnichnye marshi, pribory santexnicheskogo oborudovaniya, markirovku osey i proemov, postavit vnutrennie i narujnye razмеры, vyполnit markirovku pomesheniy i sostavit ix eksplikatsiyu, postavit ploщadi pomesheniy, vysotnye otmetki na vхode i otmetku pola pervogo etaja.

Вариант 6

Фасад 1-6



Схема плана 1-го этажа



Масштаб

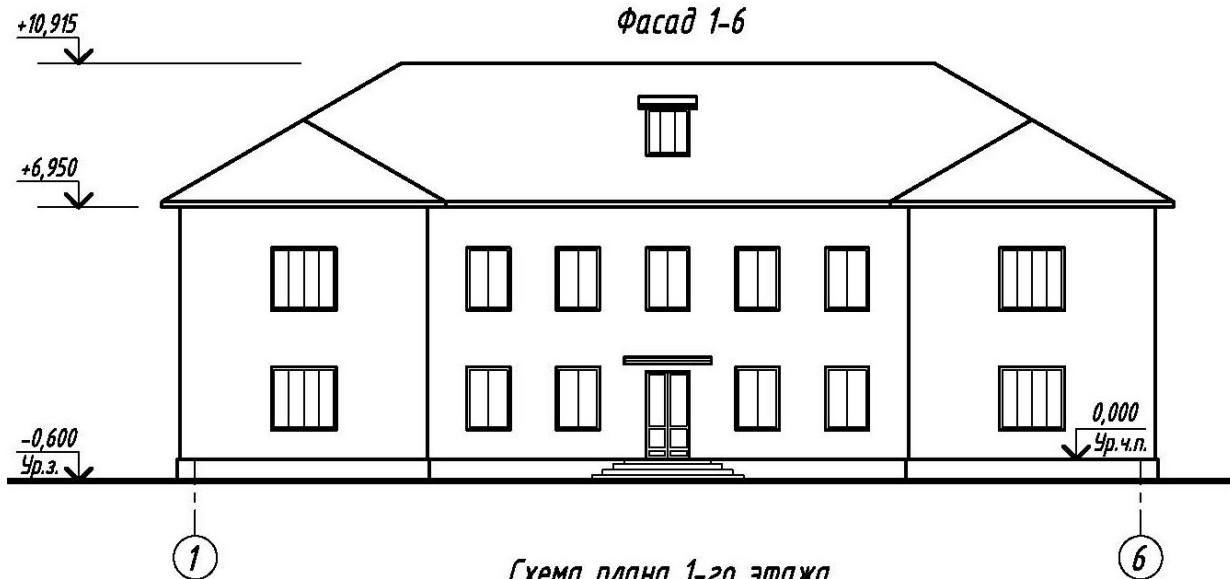
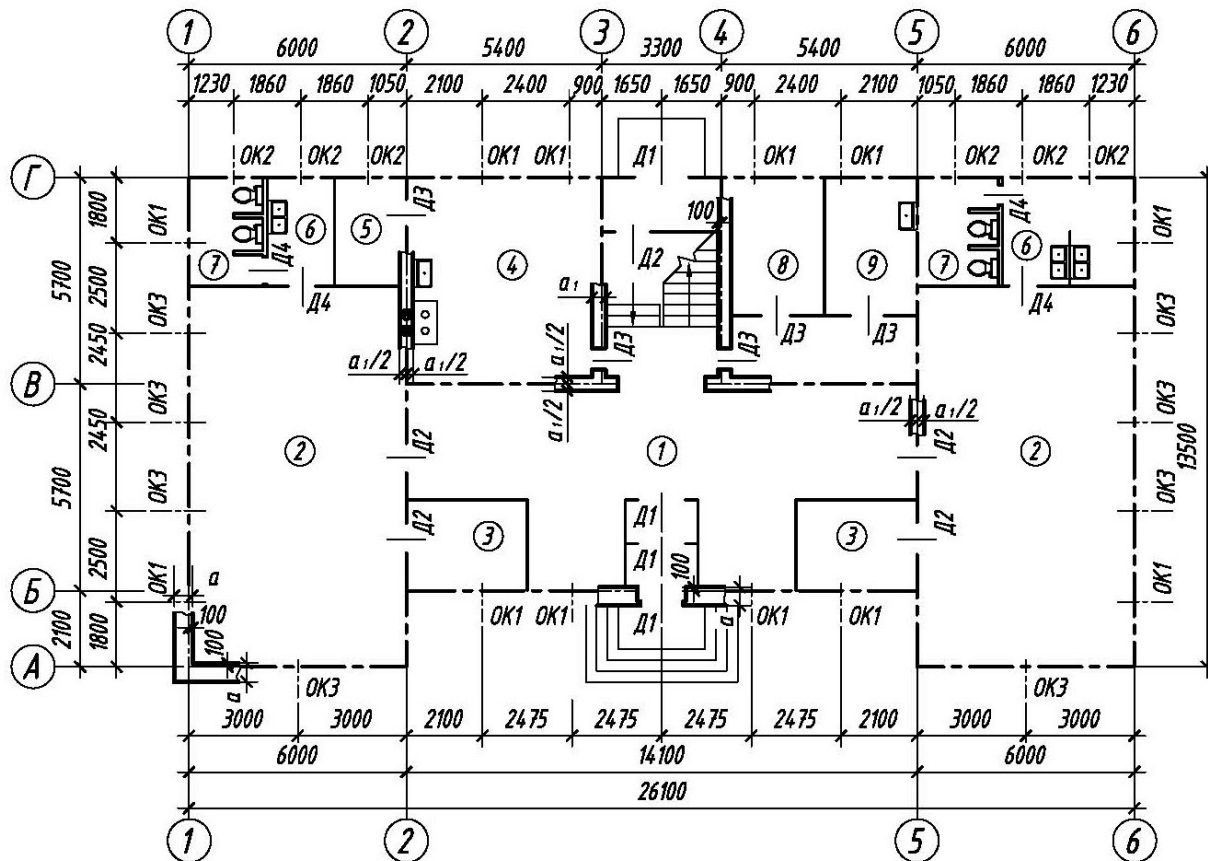
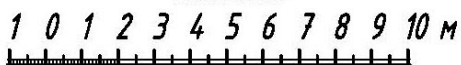

Ris. 3.14. Detskiy sad

Variant 6

Opisanie k zadaniyu: «Detskiy sad» (sm. ris. 3.14)

V zadanii dany shema plana pervogo etaja i fasad dvuxetajnogho zdaniya detskogo sada. Steny zdaniya kirpichnyye: naryujnyye tolshinoy v dva s polovinoy kirpicha, vnutrennie – v poltora. Peregorodki iz kirpicha tolshinoy 120 mm. Zdanie oborudovano vodoprovodom, kanalizatsiey i sentralnyy otopleniem. Okonnyye proemy s chetvertyami, pereplety s dvoynym ostekleniem. Dvernyye proemy: naryujnyye s chetvertyami, vnutrennie bez chetverty. Na sheme plana ukazano razmeshchenie santexnicheskogo oborudovaniya, kuxonnogo ochaga, ventilyatsionnykh i dymovykh kanalov; osi naryujnykh i vnutrennykh kapitalnykh sten pokazany tolstyimi shtrixpunktirnyimi liniyami, peregorodki – sploshnyimi. V zadanii pokazany razмеры meждu osyami sten, okonnymi i v ryade sluchaev dvernymi proemami, razmeshchenie lestnichnoy kletki.

Okonnyye i dvernyye proemy oboznacheny: OK1, OK2, D1, D2 i t. d., a ix razмеры pod okonnyye i dvernyye bloki privedeny v spesifikatsiyakh (tabl. 3.13, 3.14).

Tablitsa 3.13

Spesifikatsiya okonnykh proemov

Oboznachenie	Tip okonnykh blokov	Razмеры proema, mm	
		shirina b	высота h
OK1	Razdelnyy dvuxstvorchatyy	1210	1810
OK2	Razdelnyy trexstvorchatyy	910	1810

Tablitsa 3.14

Spesifikatsiya dvernnykh proemov

Oboznachenie	Tip dvernnykh blokov	Razмеры proema, mm	
		shirina b	высота h
D1	Dvupolnyy derevyannyy	1510	2410
D2	Dvupolnyy derevyannyy	1510	2110
D3	Odnopolnyy derevyannyy	910	2110
D4	Odnopolnyy derevyannyy	760	2110

Razmeshchenie peregorodok i nedostayuushie razмеры chastey zdaniya opredelyayutsya po cherteжу s pomoshchyu lineynogo masshtaba.

Na sheme plana pokazany pomesheniya pervogo etaja: 1 – vestibul s dvoynym tamburom, 2 – grupповые komnaty, 3 – krovatnyye komnaty, 4 – kuxnya, 5 – kladovaya, 6 – umyvalnyye, 7 – ubornyye, 8 – komnata zaveduyushchego, 9 – komnata vracha.

V rabote trebuetsya:

1. Vychertit plan pervogo etaja v masshtabe 1:100.
2. Na plane nanesti: tolshinu sten i peregorodok, okonnyye i dvernyye proemy, lestnichnyye marshi, pribory santexnicheskogo oborudovaniya, markirovku osey i proemov, razмеры, naimenovanie pomesheniya i ix ploshchadi, vysotnyye otmetki na vxode i otmetku pola pervogo etaja.

Variant 7

Opisanie k zadaniyu: «Dom otдыxa lokomotivnykh brigad» (sm. ris. 3.15)

V zadanii даны схема plana pervogo etaja i fasad dvuxetajного doma otдыxa lokomotivnykh brigad. Steny zdaniya kirpichные: naryjные толщिनou v два s polovinoу kirpicha, vnutrennie v poltora. Peregorodki iz kirpicha толщिनou 120 mm.

Na sxeme plana zdaniya privedeny razмеры meжду osyami sten i proemov, pokazano razmeshenie lestnichnoy kletki, santexnicheskogo oborudovaniya, a takje privyazka sten zdaniya k koordinatsionным osyam. Osi sten pokazаны utolщennymi shtrixpunktirnymi liniyami, peregorodki – sploshnymi. Okonные proemy s chetvertyami, pereplety s dvoynым ostekleniem. Dverные proemy: naryjные s chetvertyami, vnutrennie bez chetvertey. Okonные i dverные proemy oboznachenы: OK1, OK2, D1, D2, D3, a ix razмеры pod okonные i dverные bloki privedeny v spesifikatsiyax (tabl. 3.15, 3.16).

Tablitsa 3.15

Spesifikatsiya okonных proemov

Oboznachenie	Tip okonных blokov	Razмеры proema, mm	
		shirina b	высота h
OK1	Razdelный dvuxstvorchatый	1210	1510
OK2	Razdelный trexstvorchatый	1810	1510

Tablitsa 3.16

Spesifikatsiya dverных proemov

Oboznachenie	Tip dverных blokov	Razмеры proema, mm	
		shirina b	высота h
D1	Dvupolный derevyанный	1210	2110
D2	Odnopolный derevyанный	910	2110
D3	Odnopolный derevyанный	610	2110

Razmeshenie peregorodok i nedostayuщие razмеры chastey zdaniya opredelyayutsya po cher-teju v sootvetstvii s lineynым masshtabom.

Na sxeme plana zdaniya privedena planirovka pomesheniy pervogo etaja: 1 – garde-rob M, 2 – dush M, 3 – dezokamera, 4 – garderob J, 5 – dush J, 6 – lestnitsa, 7 – kuxnya, 8 – komnata otдыxa, 9 – sushilnoe otdelenie, 10 – prachechnaya, 11 – koridor, 12 – tambur, 13 – naryadchik, 14 – komnata xraneniya veshеy, 15 – tualet.

V rabote trebuetsya:

1. Vyichertit plan pervogo etaja v masshtabe 1:100.
2. Na plane nanesti: толщину sten i peregorodok, vnutrennie razмеры pomesheniy v svetu, privyazku dverных proemov, naryjные razмеры zdaniya (prostenki i proemy), privyazku kapitalных sten, okonные i dverные proemy, lestnichные marshi, pribory sanitarnotexnicheskogo oborudovaniya, markirovku osey i proemov, ukazat naimenovanie pomesheniy i ix ploщadi, высотные otmetki na vxode i otmetku pola pervogo etaja.

Вариант 8

Фасад 1-4



Схема плана 1-го этажа



Масштаб

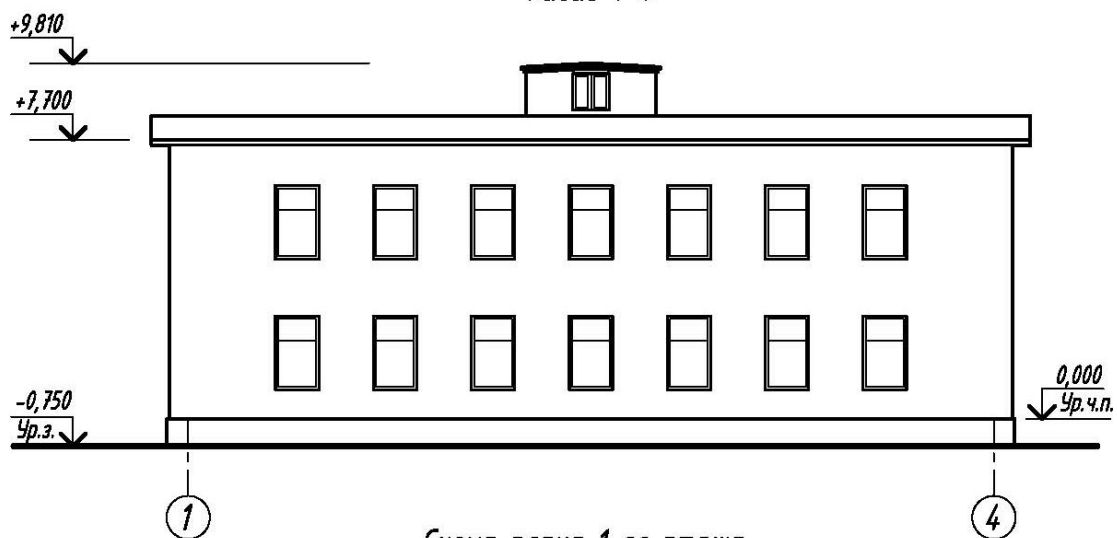
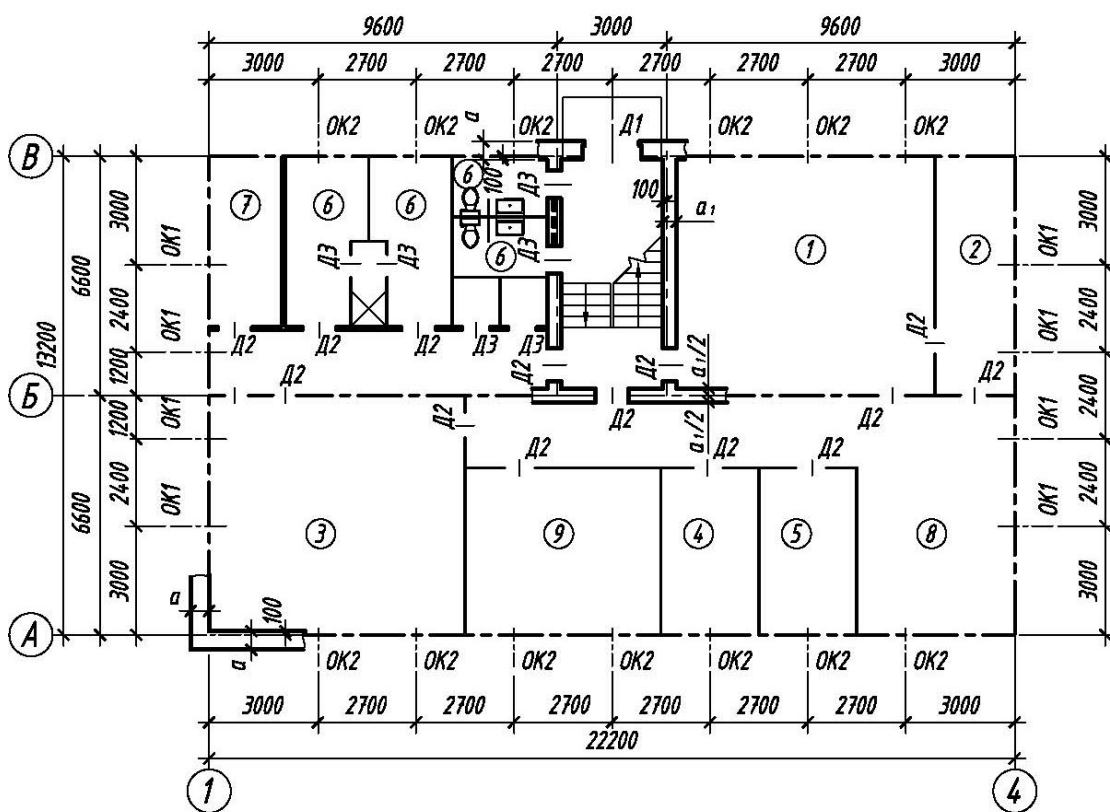
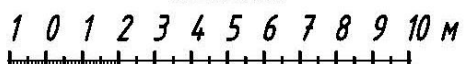

Ris. 3.16. Dom svyazi

Variant 8

Opisanie k zadaniyu: «Dom svyazi» (sm. ris. 3.16)

V zadanii dany: sxema plana pervogo etaja i fasad dvuxetajnogo zdaniya doma svyazi. Steny zdaniya kirpichnye: narujnye tolщinoy v dva s polovinoй kirpicha, vnutrennie – v poltora. Peregorodki iz kirpicha tolщinoy 120 mm. Zdanie imeet vodoprovod, kanaliza- siyu, sentralnoe otoplenie. Na sxeme plana ukazany razmery meйdu osyami sten i proemov, dano razmeshenie ventilyatsionnykh kanalov, lestnichnoy kletki, a takje privyaz- ka sten zdaniya k koordinatsionnyim osyam; osi sten pokazany shtrixpunktirnyimi liniyami, peregorodki – sploshnyimi. Okonnyye proemy s chetvertyami, pereplety s dvoynym ostekle- niem. Dvernyye proemy: narujnye s chetvertyami, vnutrennie bez chetvertey.

Okonnyye i dvernyye proemy oboznacheny: OK1, D1, D2 i t. d., a ix razmery pod okon- nyye i dvernyye bloki privedeny v spesifikatsiyax (tabl. 3.17, 3.18).

Tablitsa 3.17

Spesifikatsiya okonnykh proemov

Obozna- chenie	Tip okonnykh blokov	Razmery proema, mm	
		shirina b	высота h
OK1	Razdelnyy odnostvorchatyy	1210	2110

Tablitsa 3.18

Spesifikatsiya dvernykh proemov

Obozna- chenie	Tip dvernykh blokov	Razmery proema, mm	
		shirina b	высота h
D1	Dvupolnyy derevyannyy	1510	2410
D2	Dvupolnyy derevyannyy	1510	2110
D3	Odnopolnyy derevyannyy	910	2110
D4	Odnopolnyy derevyannyy	760	2110

Razmeshenie peregorodok i nedostayuщie razmery chasteй zdaniya opredelyayutsya po cherteju v sootvetstvii s lineynym masshtabom.

Na sxeme plana pokazany pomesheniya pervogo etaja: 1 – zal apparatov Morze; 2 – ventkamera; 3 – blokstansiya; 4 – akkumulyatornaya; 5 – kislotnaya; 6 – dushevyye i tualety (mujskie i jenskie); 7 – sklad; 8 – garderob; 9 – masterskie.

V rabote trebuetsya:

1. Vyichertit plan pervogo etaja v masshtabe 1:100.
2. Na plane nanesti: tolщinu sten, peregorodok, okonnyye i dvernyye proemy, lest- nichnyye marshi, pribory sanitarno-texnicheskogo oborudovaniya, markirovku osey i proe- mov, ukazat naimenovanie pomesheniy i ix ploщadi, vyсотные otmetki na vxode i otmetku pola pervogo etaja.

Вариант 9



Схема плана 1-го этажа



Ris. 3.17. Jiloy dom na 8 kvartir

Variant 9

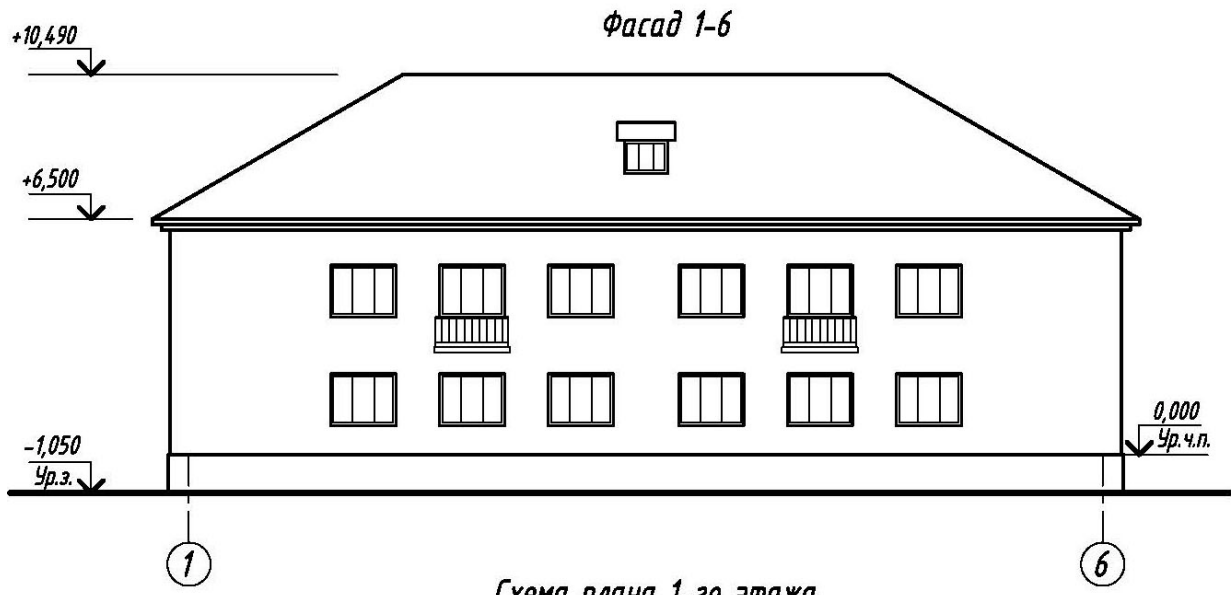
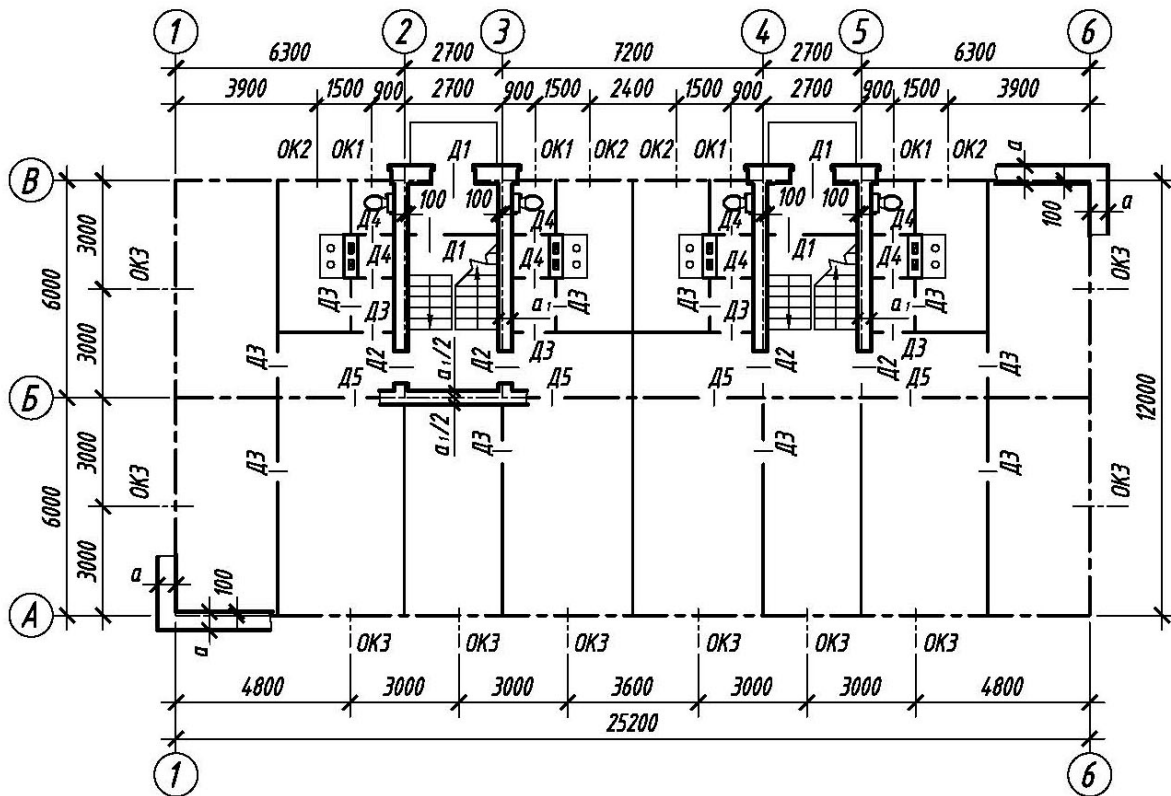
Opisanie k zadaniyu: «Jiloy dom na 8 kvartir» (sm. ris. 3.17)

V zadanii dany: shema plana pervogo etaja i fasad dvuxetajnoy jilogo doma. Ste-ny zdaniya kirpichnye: naryjnye tolstinoy v dva s polovinoy kirpicha, vnutrennie – v pol-tora. Peregorodki iz kirpicha tolstinoy 120 mm.

Na sxeme plana zdaniya privedeny razмеры meжду osyami sten i proemov, pokazano razmeshenie pechey, ventilyatsionnykh i dymovyykh kanalov, lestnichnoy kletki, a takje pri-vyazka sten zdaniya k koordinatsionnym osyam. Osi sten pokazany utolshchennymi shtrixpunk-tirnymi liniyami, peregorodki – sploshnymi. Okonnyye proemy s chetvertiyami, pereplety s dvoynym ostekleniem. Dvernyye proemy: naryjnye s chetvertiyami, vnutrennie bez chetvertyey. Okonnyye i dvernyye proemy oboznacheny: OK1, OK2, OK3, D1, D2, i t. d., a ix razмеры pod okonnyye i dvernyye bloki privedeny v spesifikatsiyax (tabl. 3.19, 3.20).

Tablitsa 3.19

Spesifikatsiya okonnykh proemov

Obozna-chenie	Tip okonnykh blokov	Razмеры proema, mm	
		shirina b	высота h
OK1	Razdelnyy dvuxstvorchatyy	910	1510
OK2	Razdelnyy dvuxstvorchatyy	1210	1510
OK3	Razdelnyy trexstvorchatyy	1810	1510

Tablitsa 3.20

Spesifikatsiya dvernykh proemov

Obozna-chenie	Tip dvernykh blokov	Razмеры proema, mm	
		shirina b	высота h
D1	Dvupolnyy derevyannyy	1210	2110
D2	Odnopolnyy derevyannyy	910	2110
D3	Odnopolnyy derevyannyy	910	2110
D4	Odnopolnyy derevyannyy	760	2110
D5	Dvupolnyy osteklennyy	1210	2110

Razmeshenie peregorodok i nedostayushie razмеры chastey zdaniya opredelyayutsya po cher-teju v sootvetstvii s lineynym masshtabom.

Na sxeme plana zdaniya privedena planirovka pomesheniya pervogo etaja.

V rabote trebuetsya:

1. Vychertit plan pervogo etaja v masshtabe 1:100.
2. Na plane nanesti: tolstinu sten i peregorodok, vnutrennie razмеры pomesheniya v svetu, privyazku dvernykh proemov, naryjnye razмеры zdaniya (prostenki i proemy), pri-vyazki kapitalnykh sten, okonnyye i dvernyye proemy, lestnichnyye marshi, pribory sanitarnotekhnicheskogo oborudovaniya, markirovku osey i proemov, ukazat naimenovanie pomesheniya i ix ploshchadi, vysotnyye otmetki na vxode i otmetku pola pervogo etaja.

9,10-grafik ishlar varianti

Вариант 1

Геометрическая схема фермы М 1:50

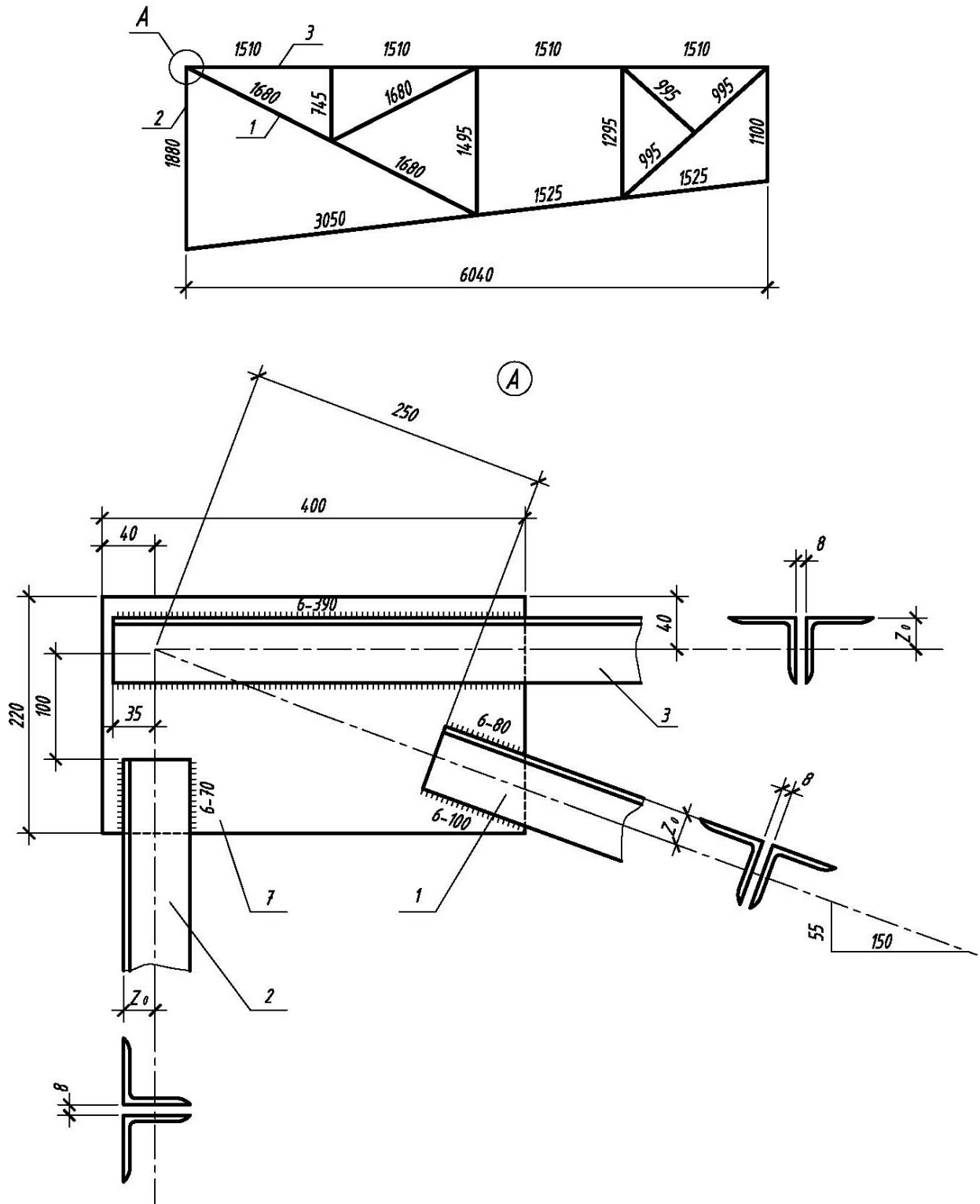

Вариант 2

Геометрическая схема фермы М 1:50

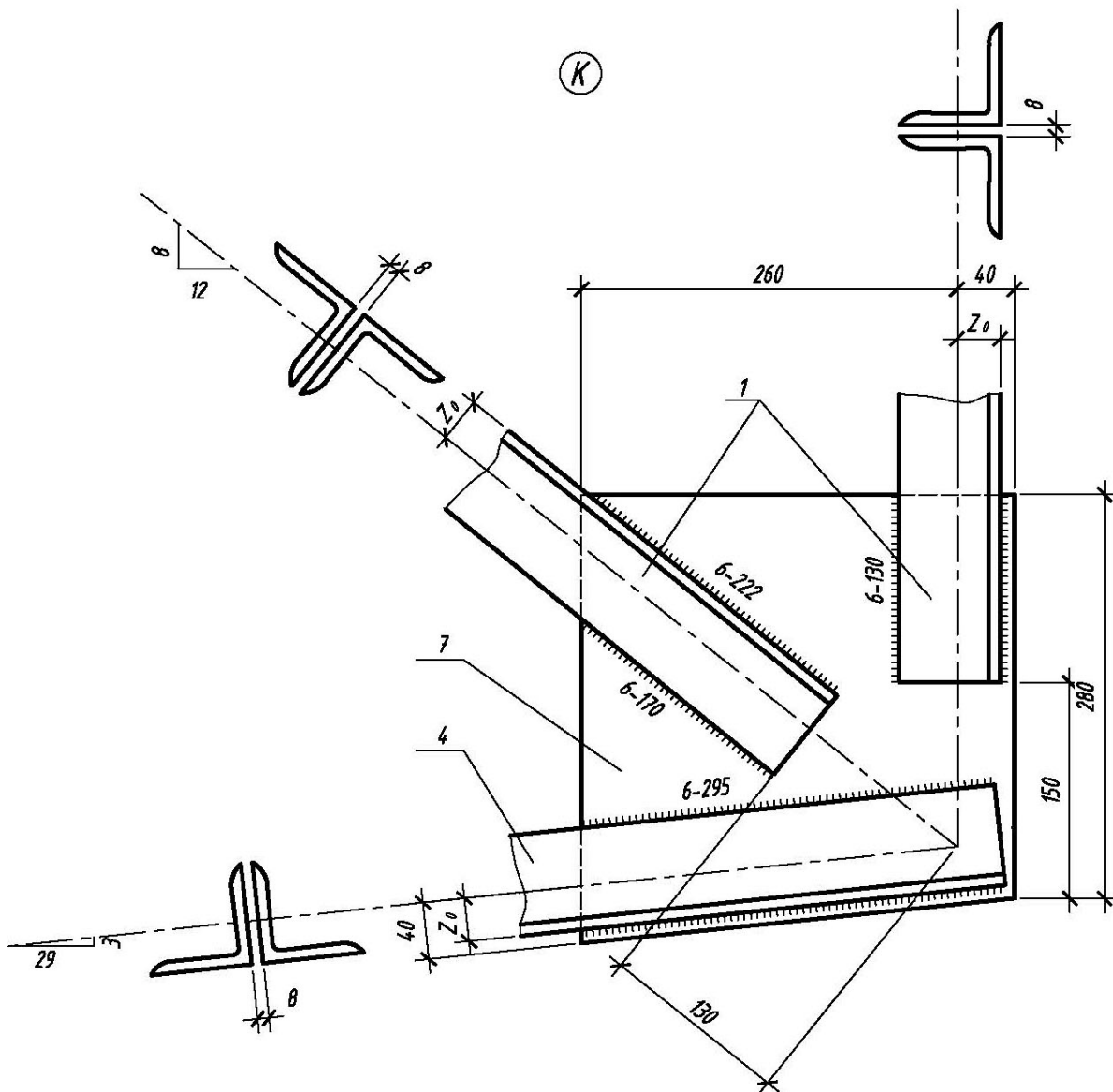
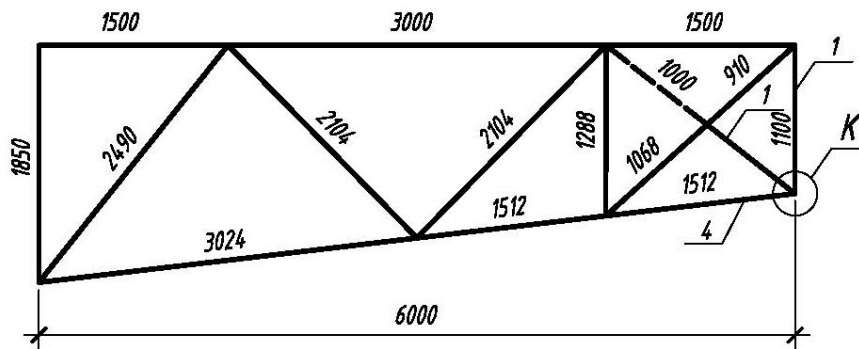

Вариант 3

Геометрическая схема фермы М 1:50

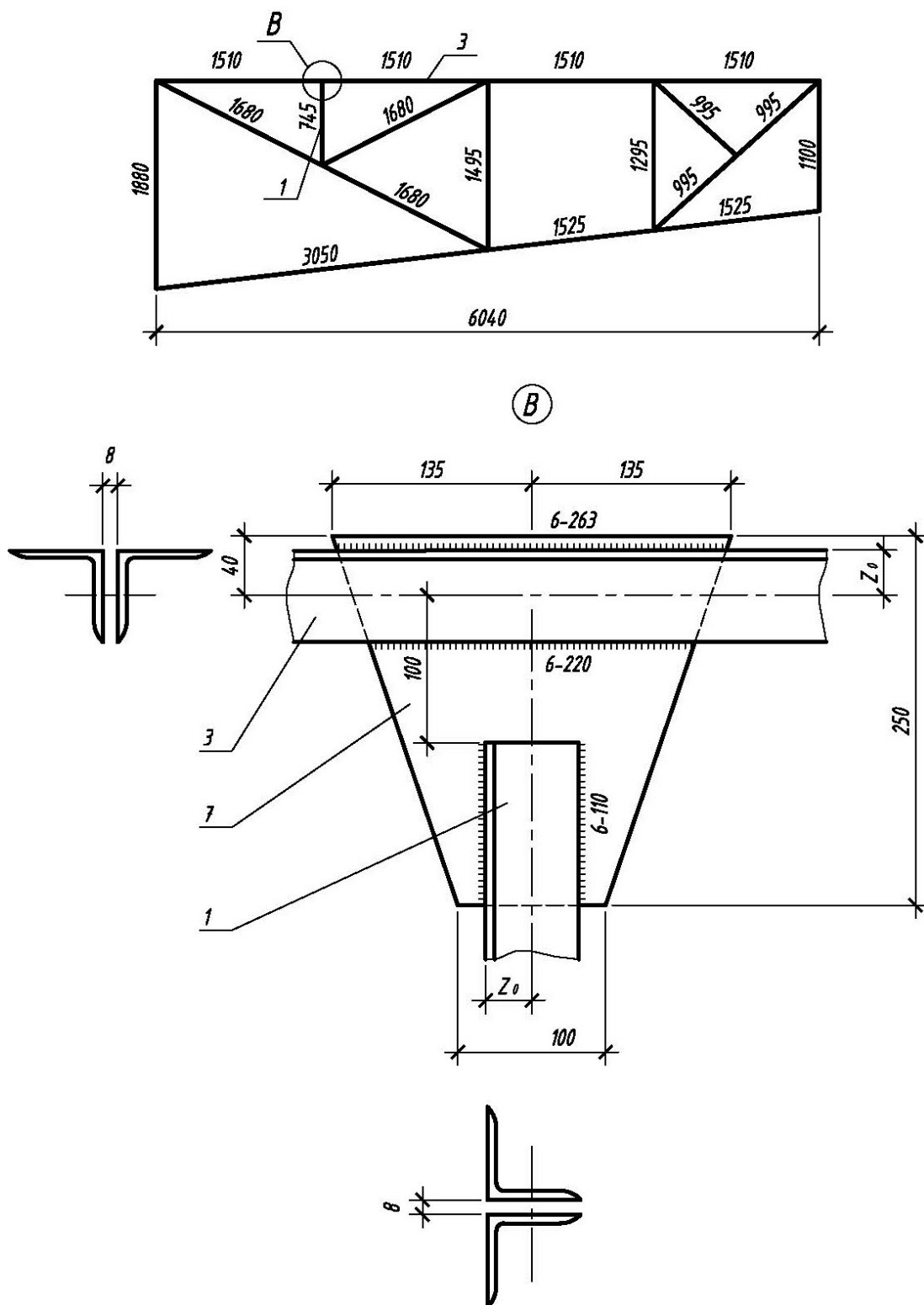

Вариант 4

Геометрическая схема фермы М 1:50

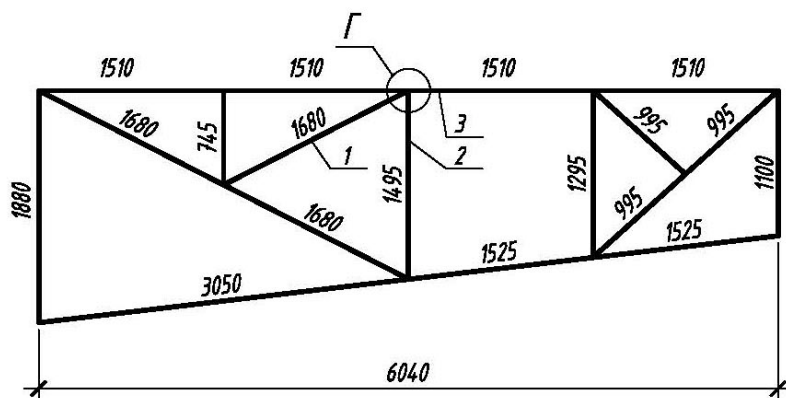

Г

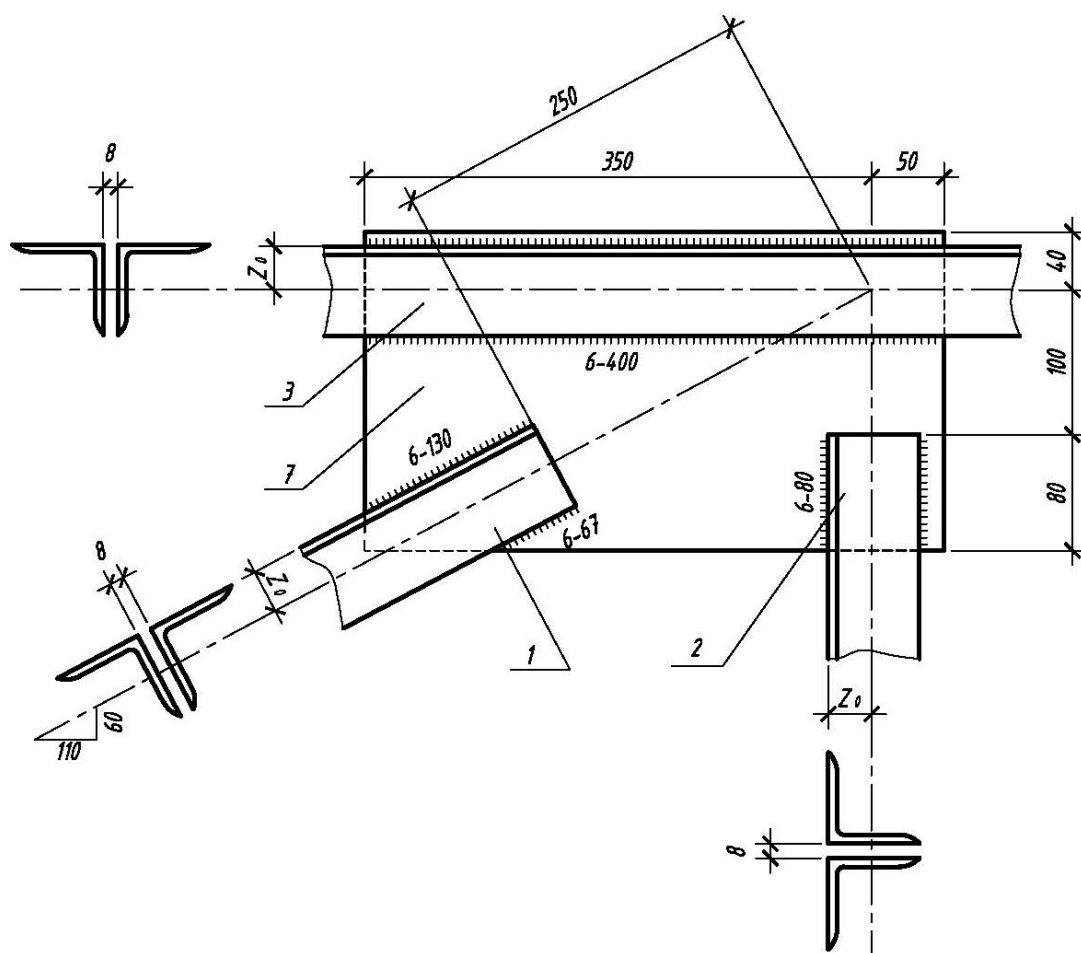

Вариант 6

Геометрическая схема фермы М 1:50

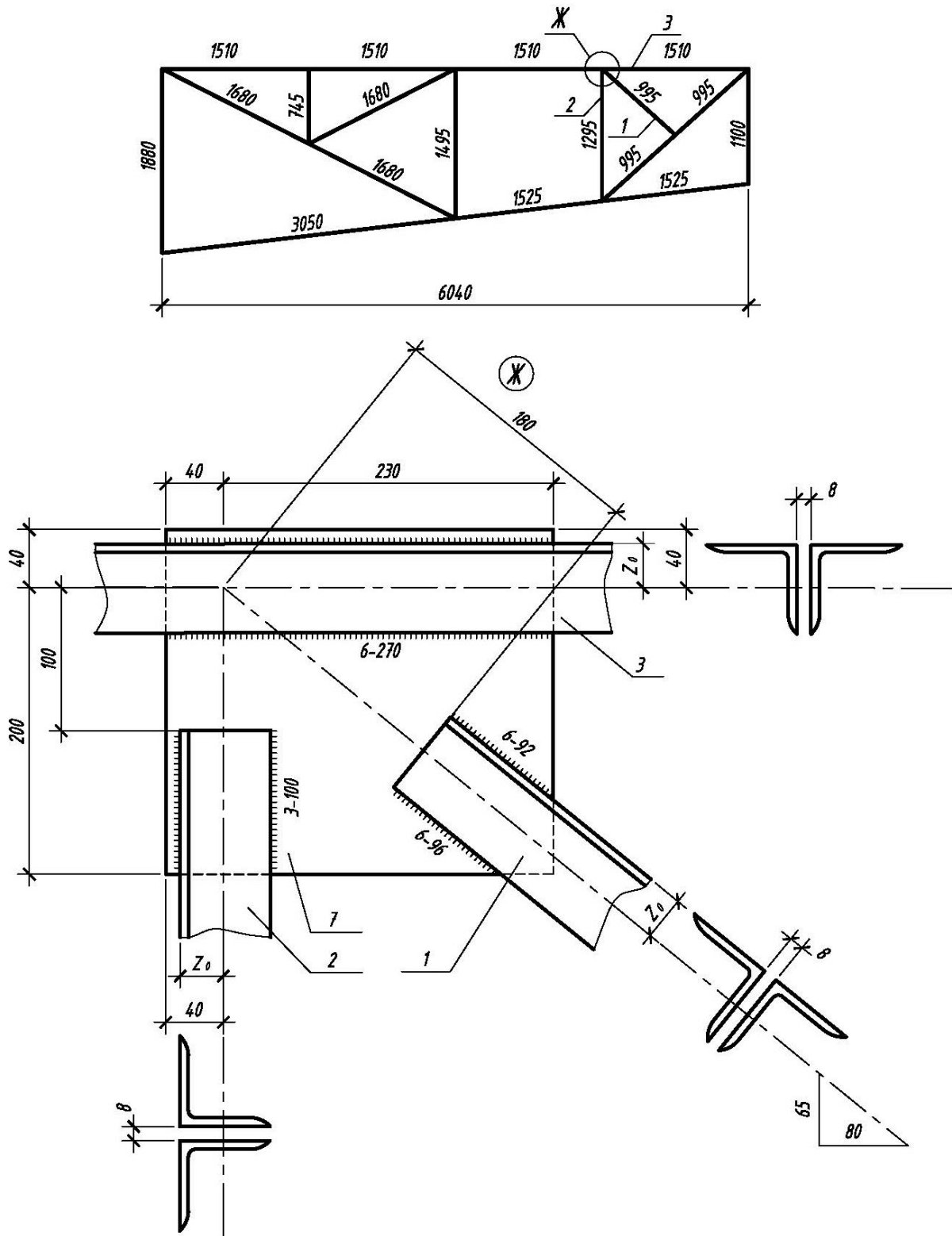

Вариант 7

Геометрическая схема фермы М 1:50

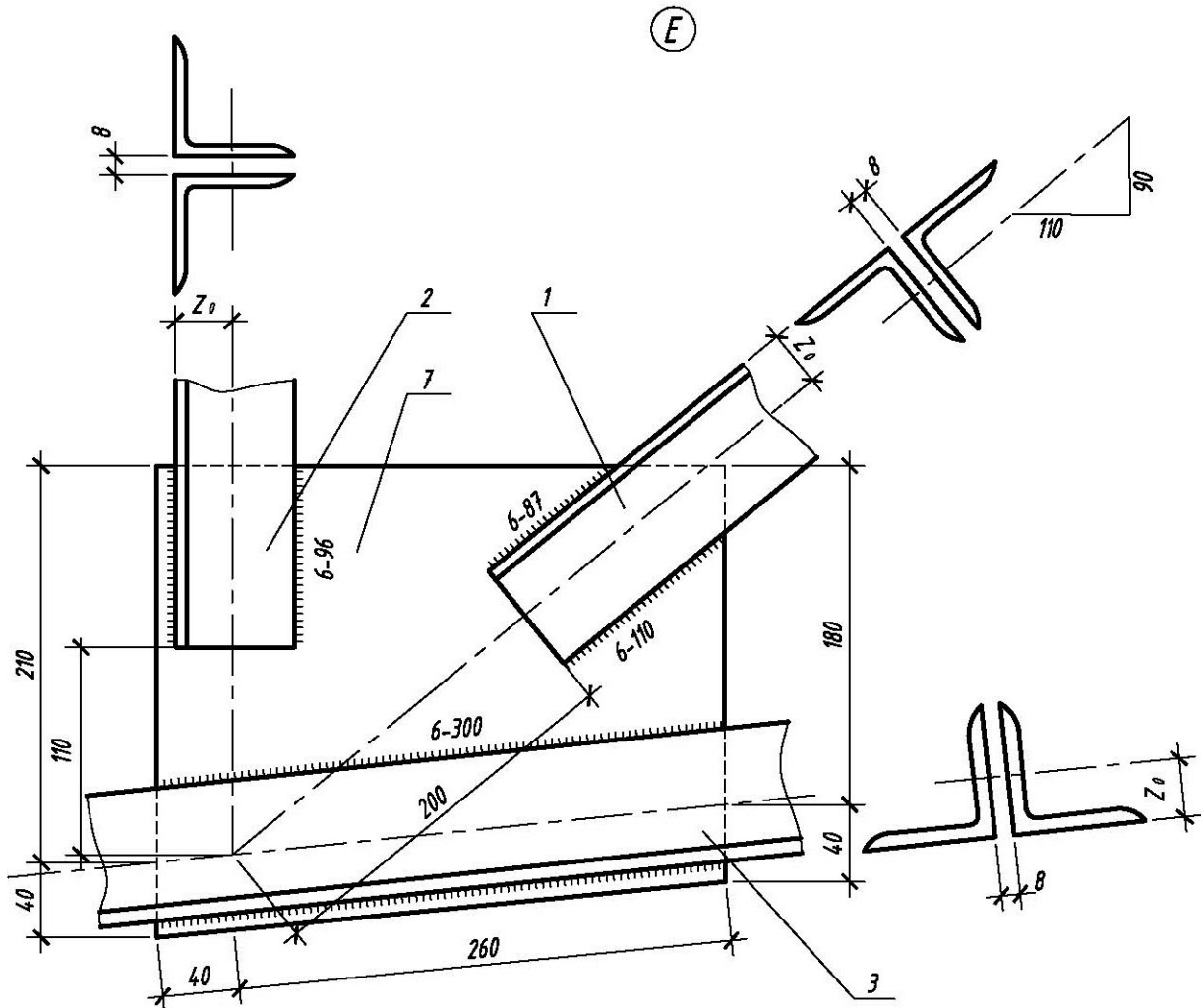
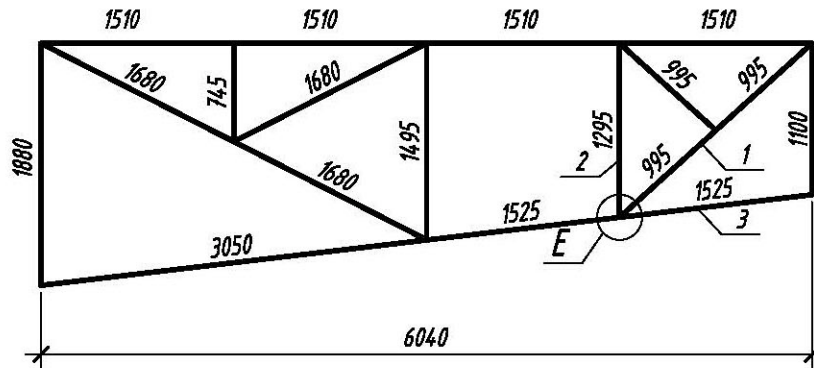

Вариант 8

Геометрическая схема фермы М 1:50

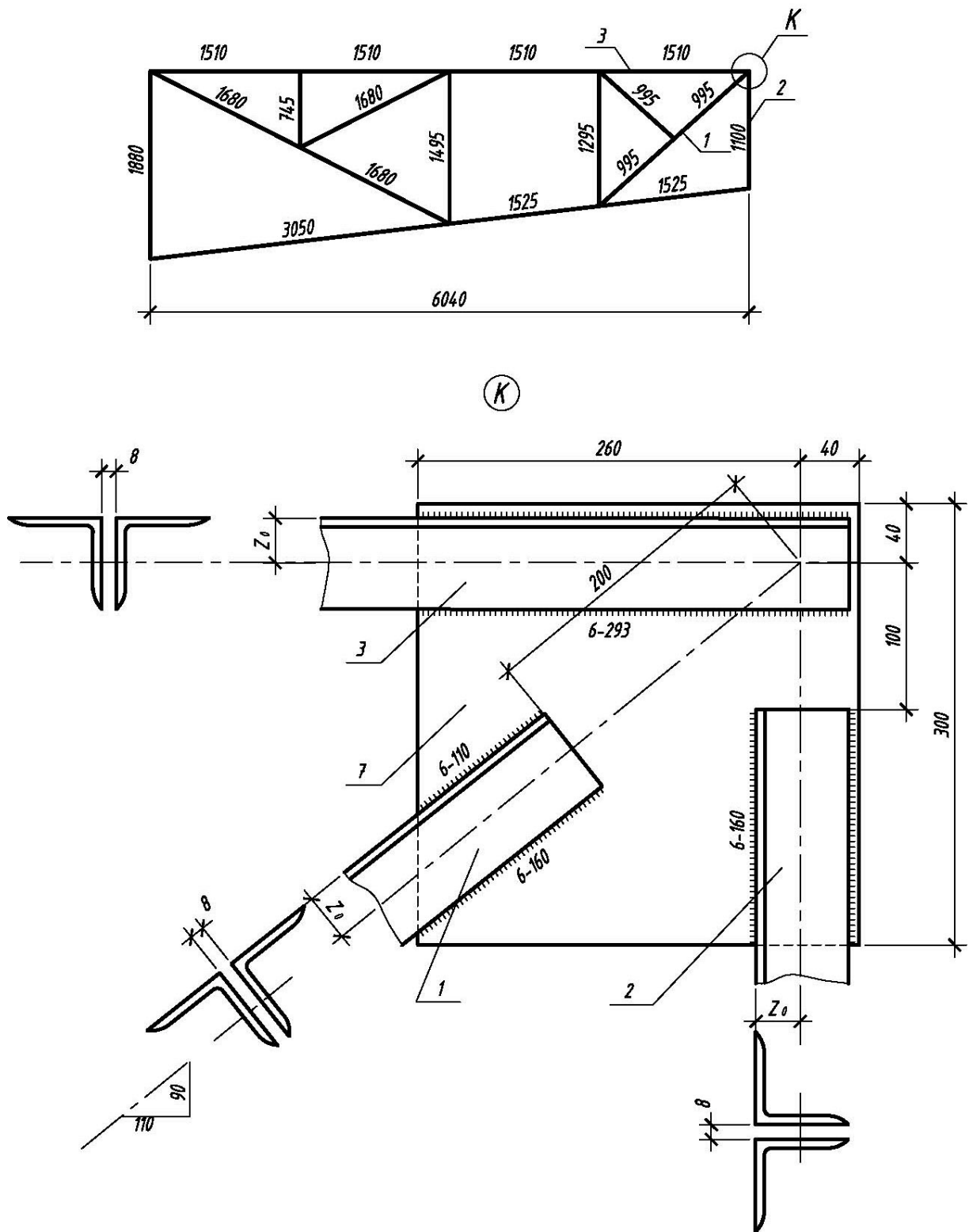

Вариант 9

Геометрическая схема фермы М 1:50

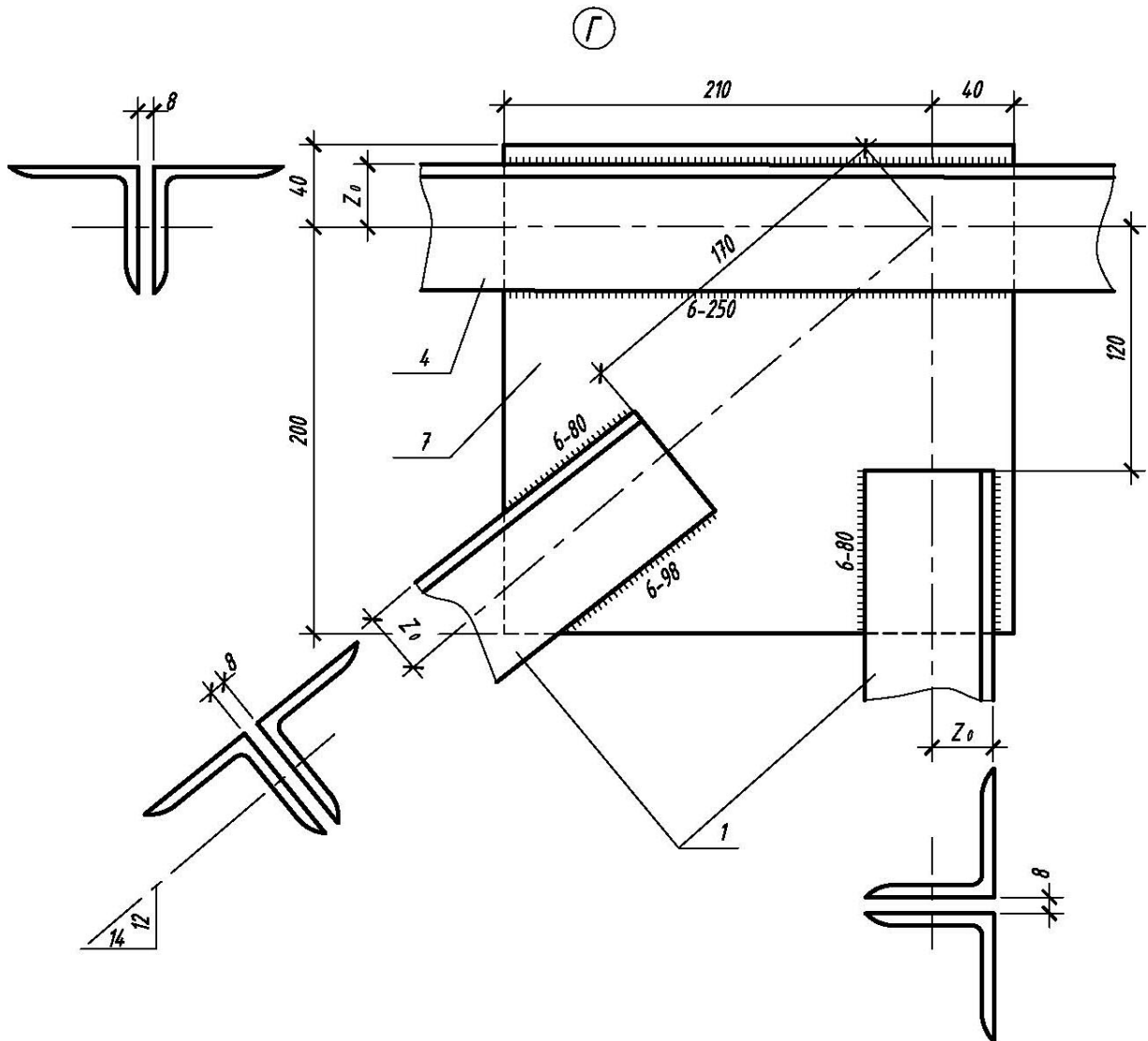
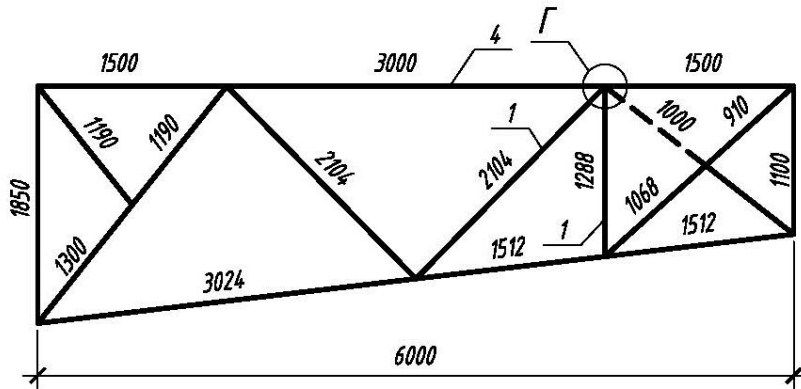

GRAFIK ISHLAR UCHUN VARIANTLAR

2-semestr

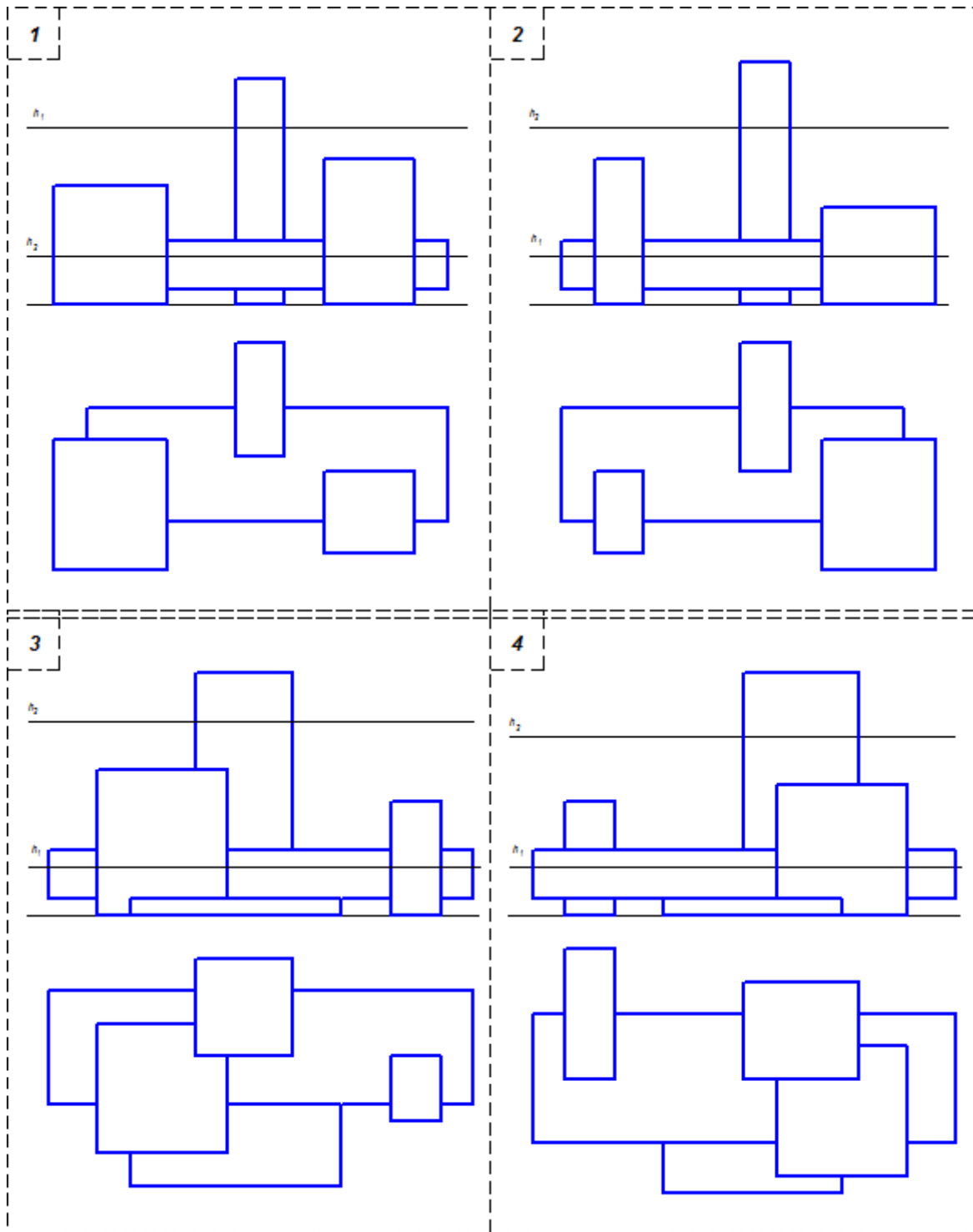
1-grafik ishlar varianti

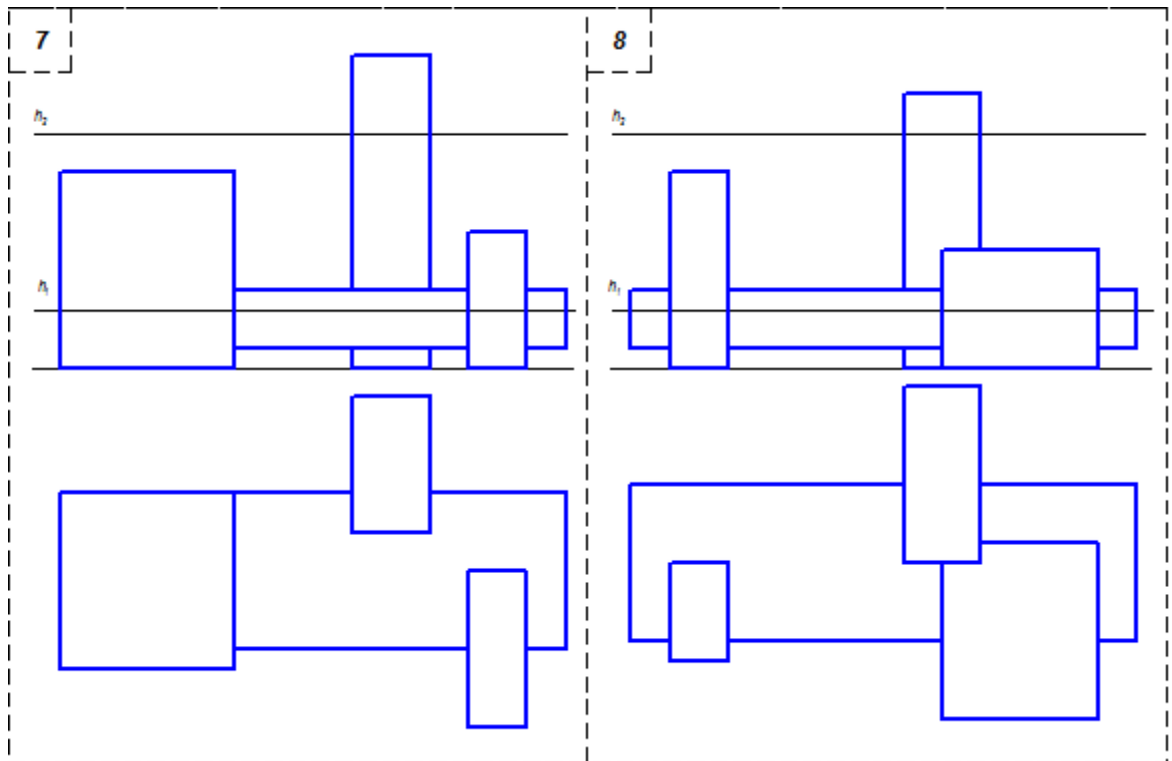
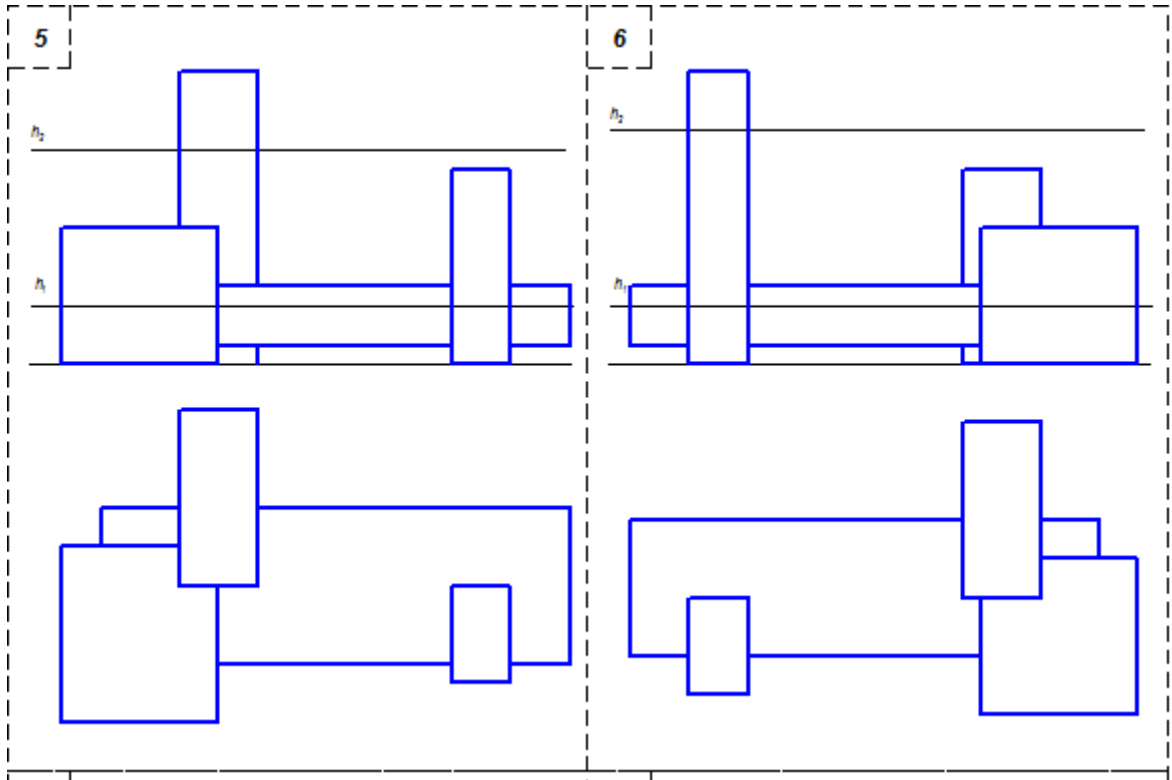

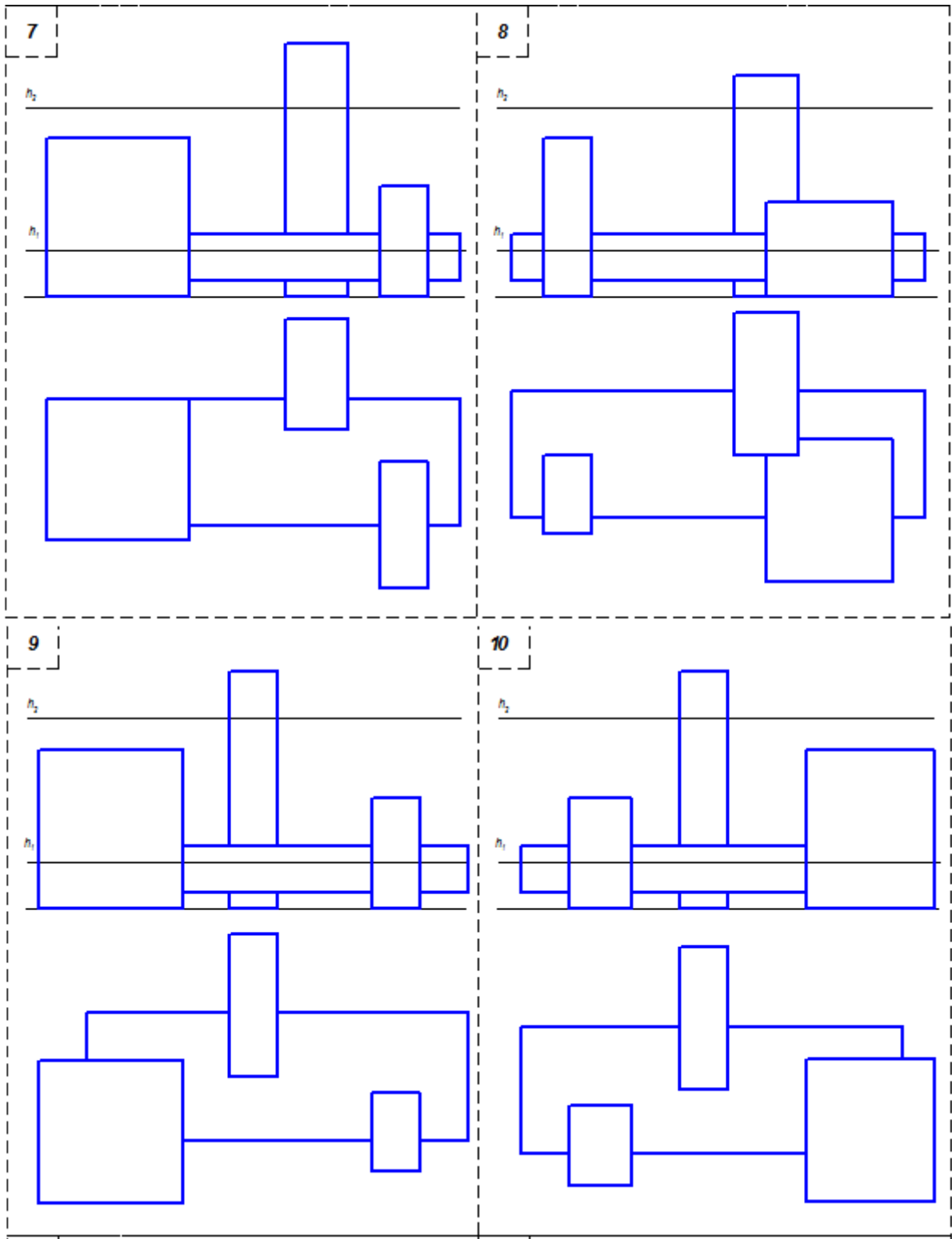

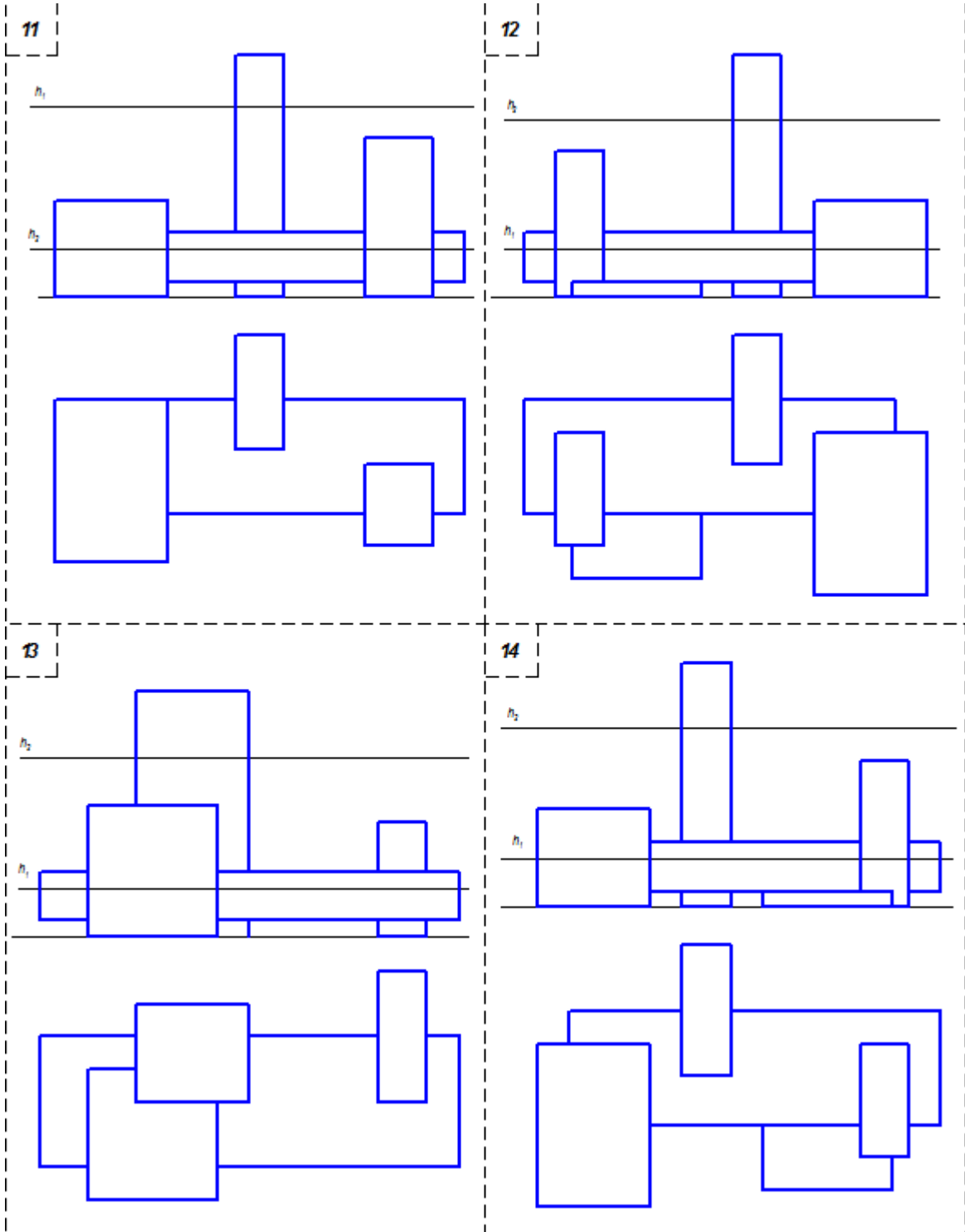

2-grafik ishlar varianti

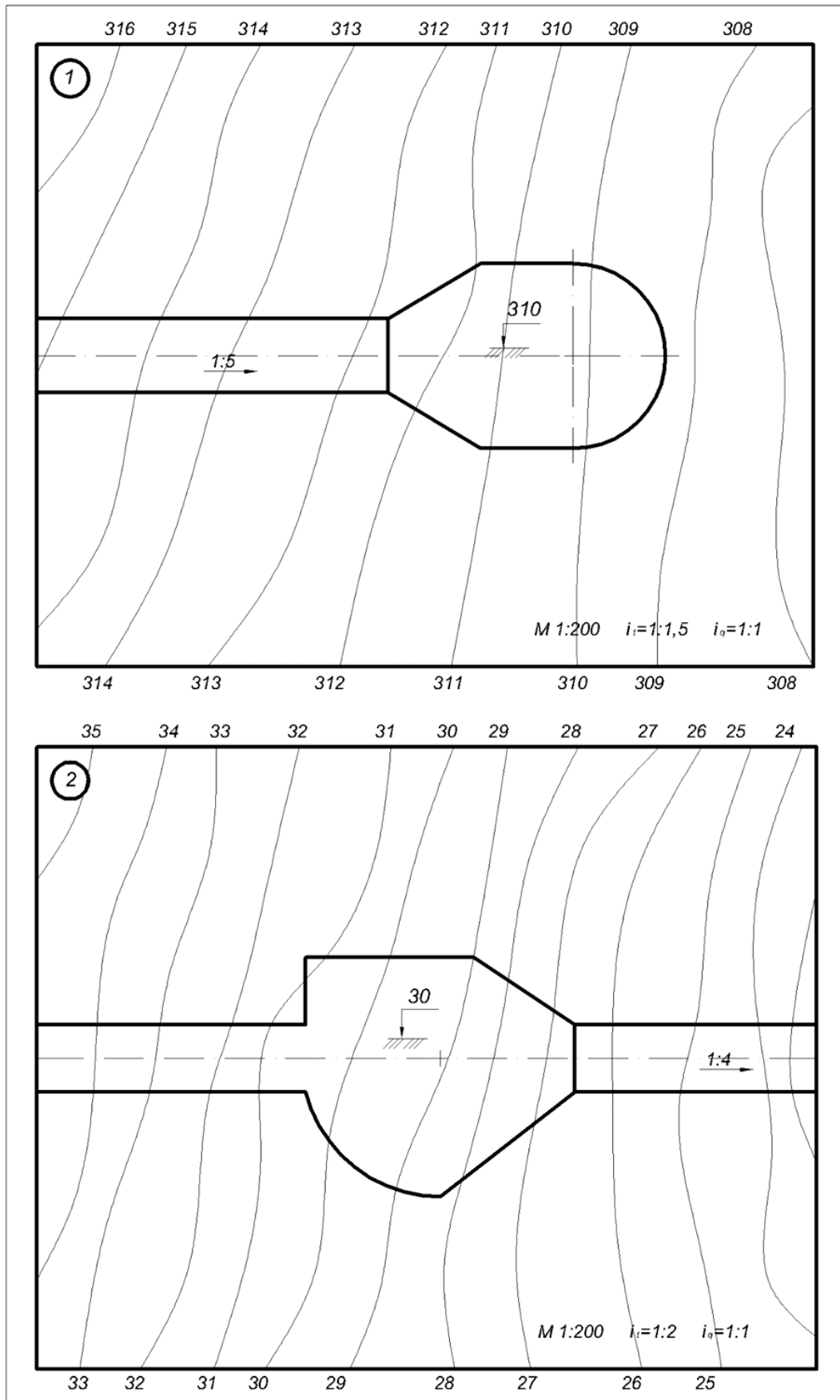

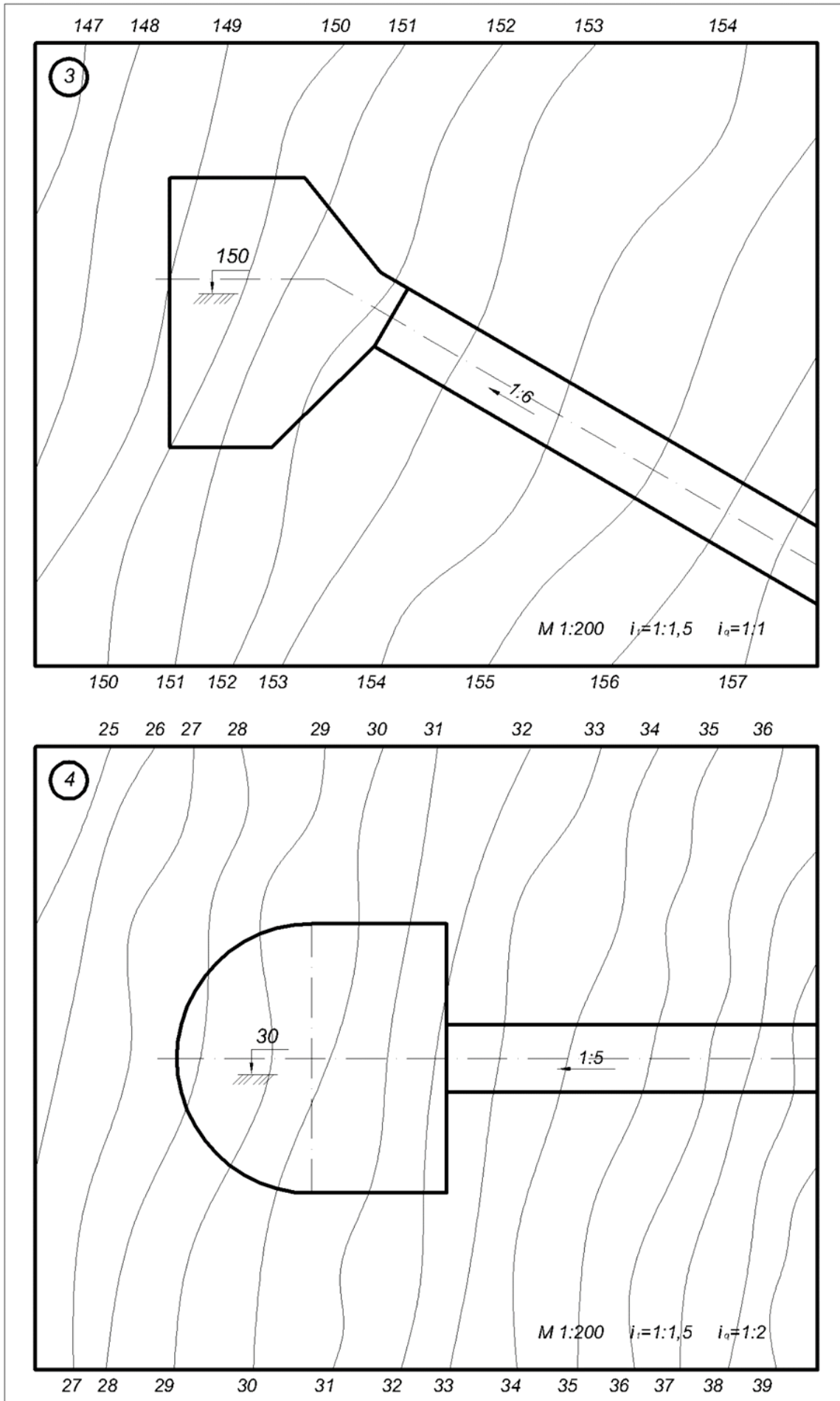

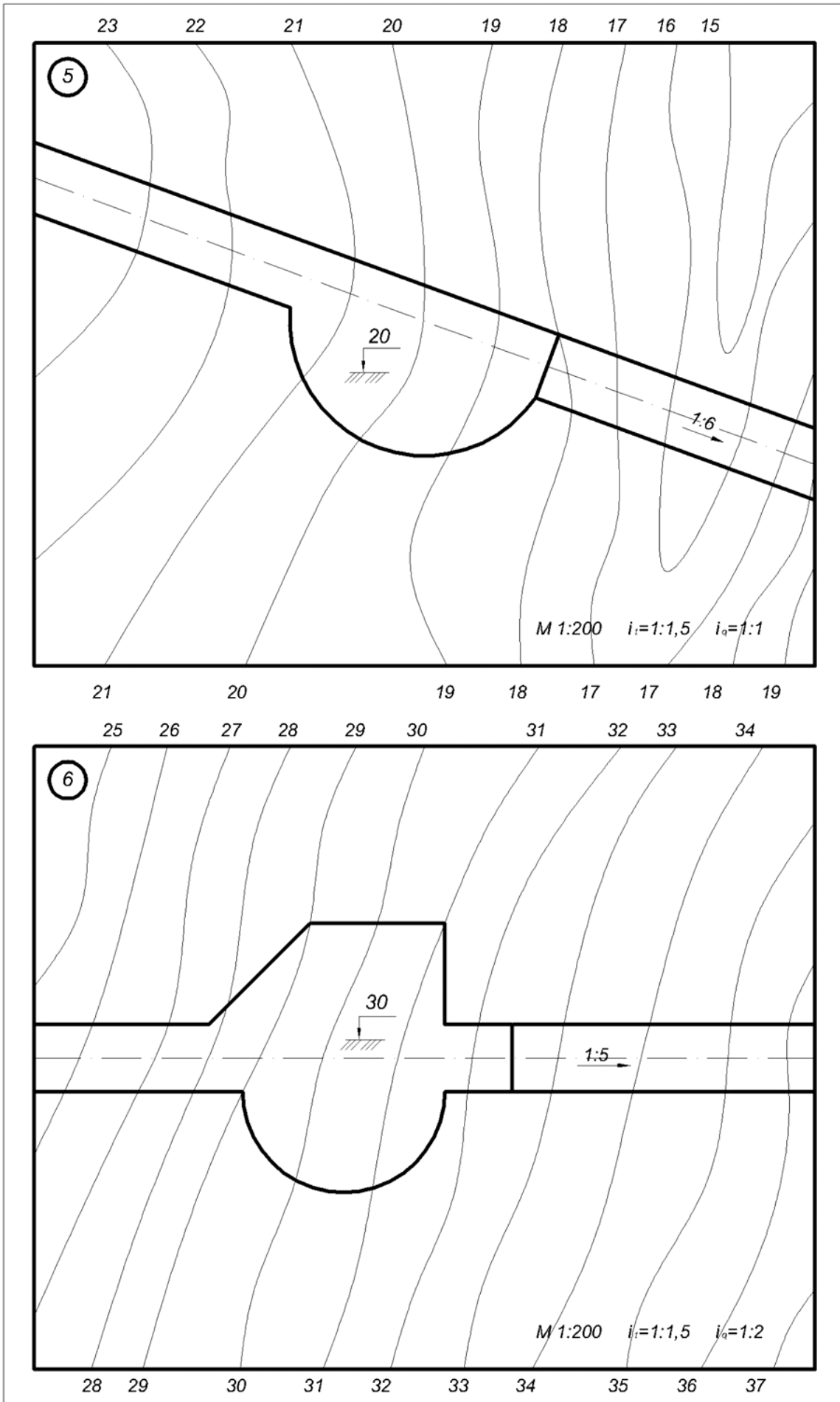

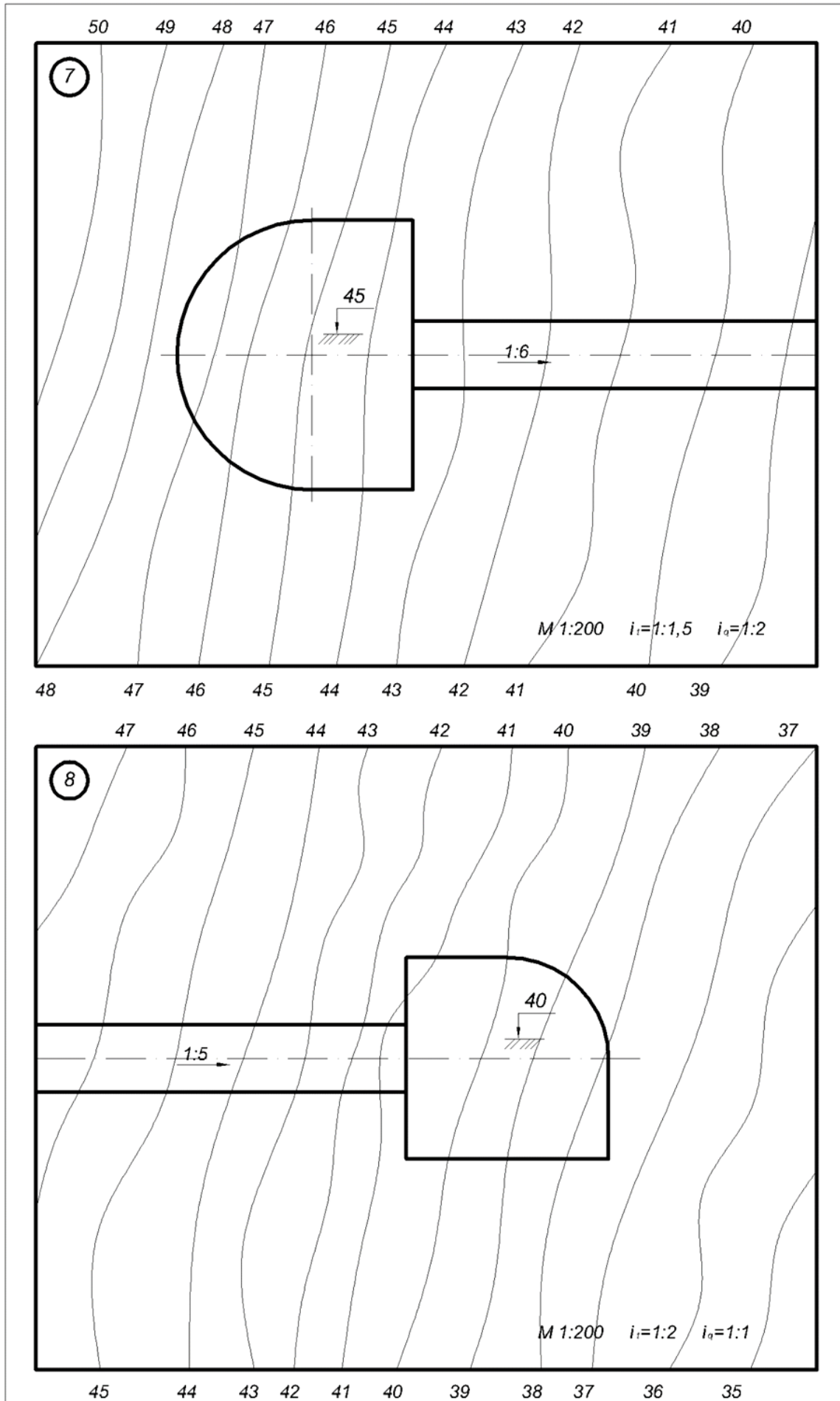

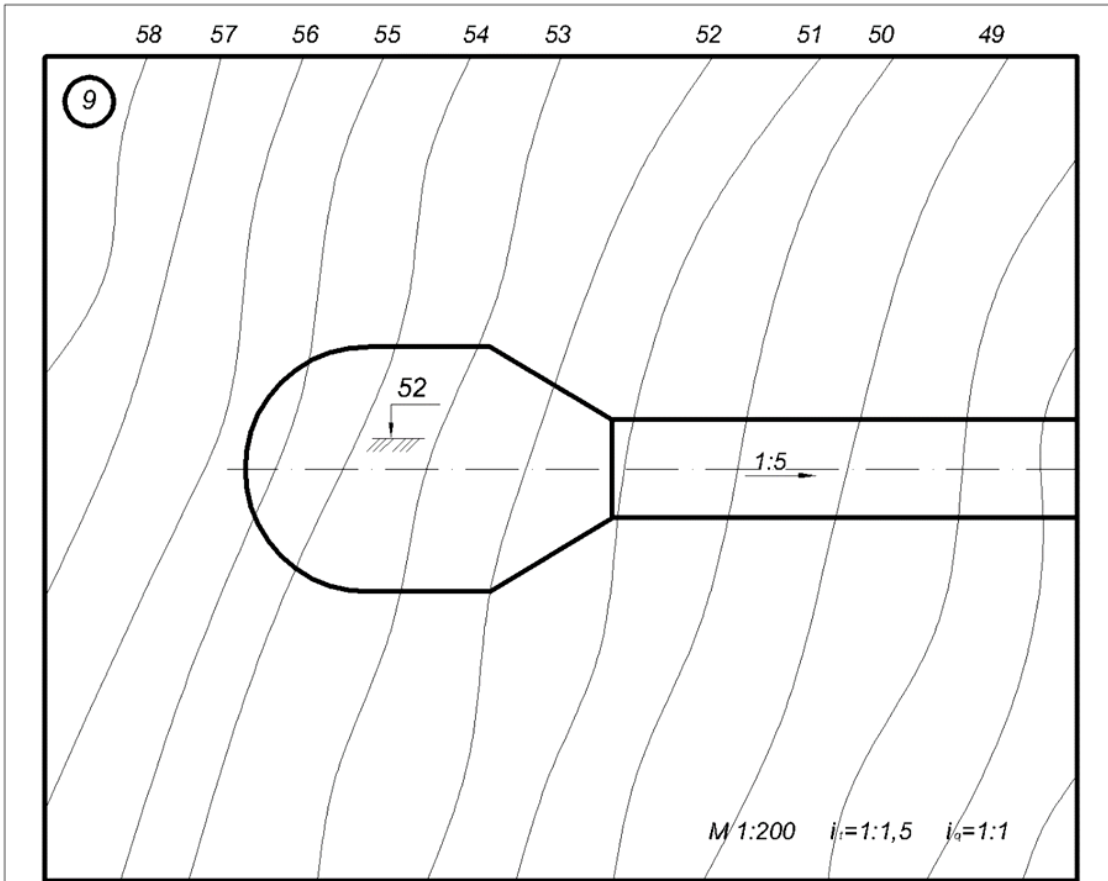

55 54 53 52 51 50 49 48 47 46

90 89 88 87 86 85 84 83 82 81 80 79

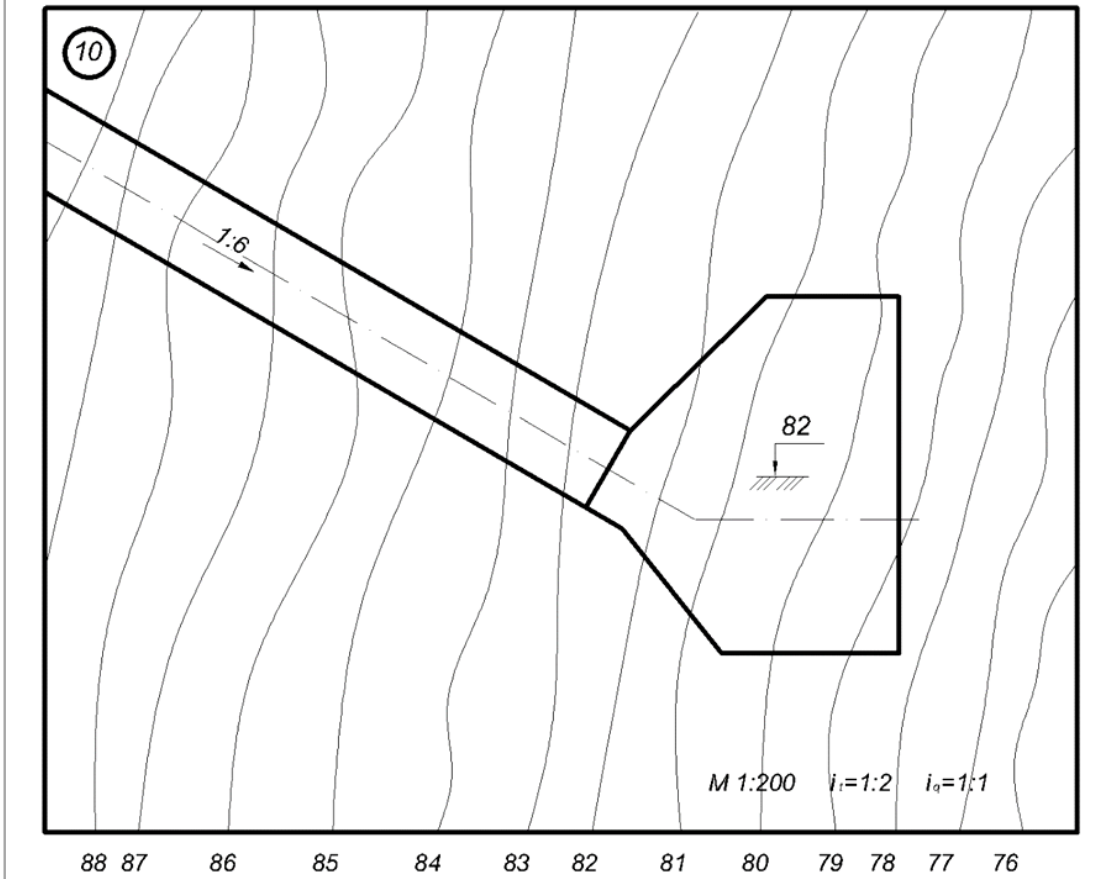

88 87 86 85 84 83 82 81 80 79 78 77 76

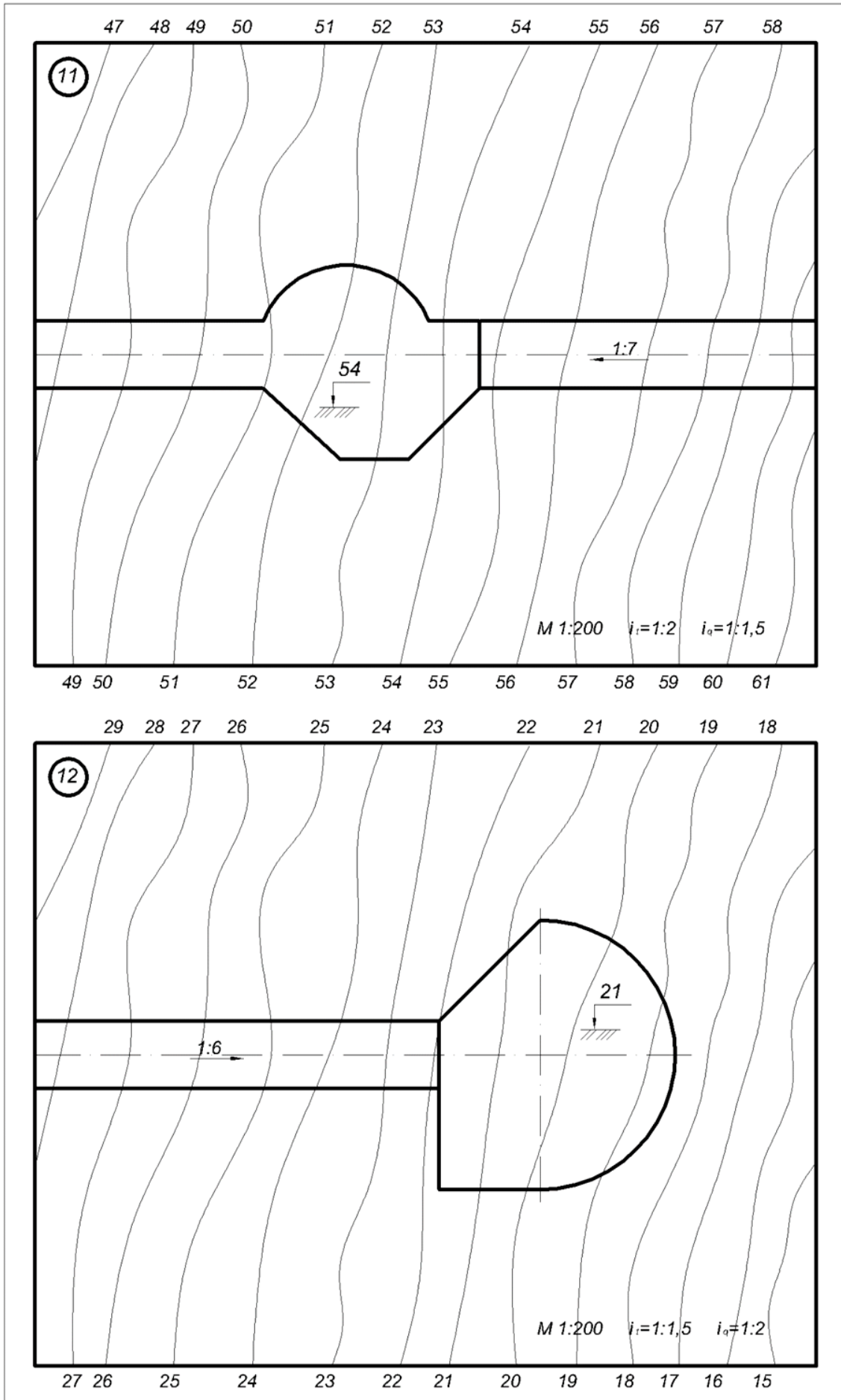

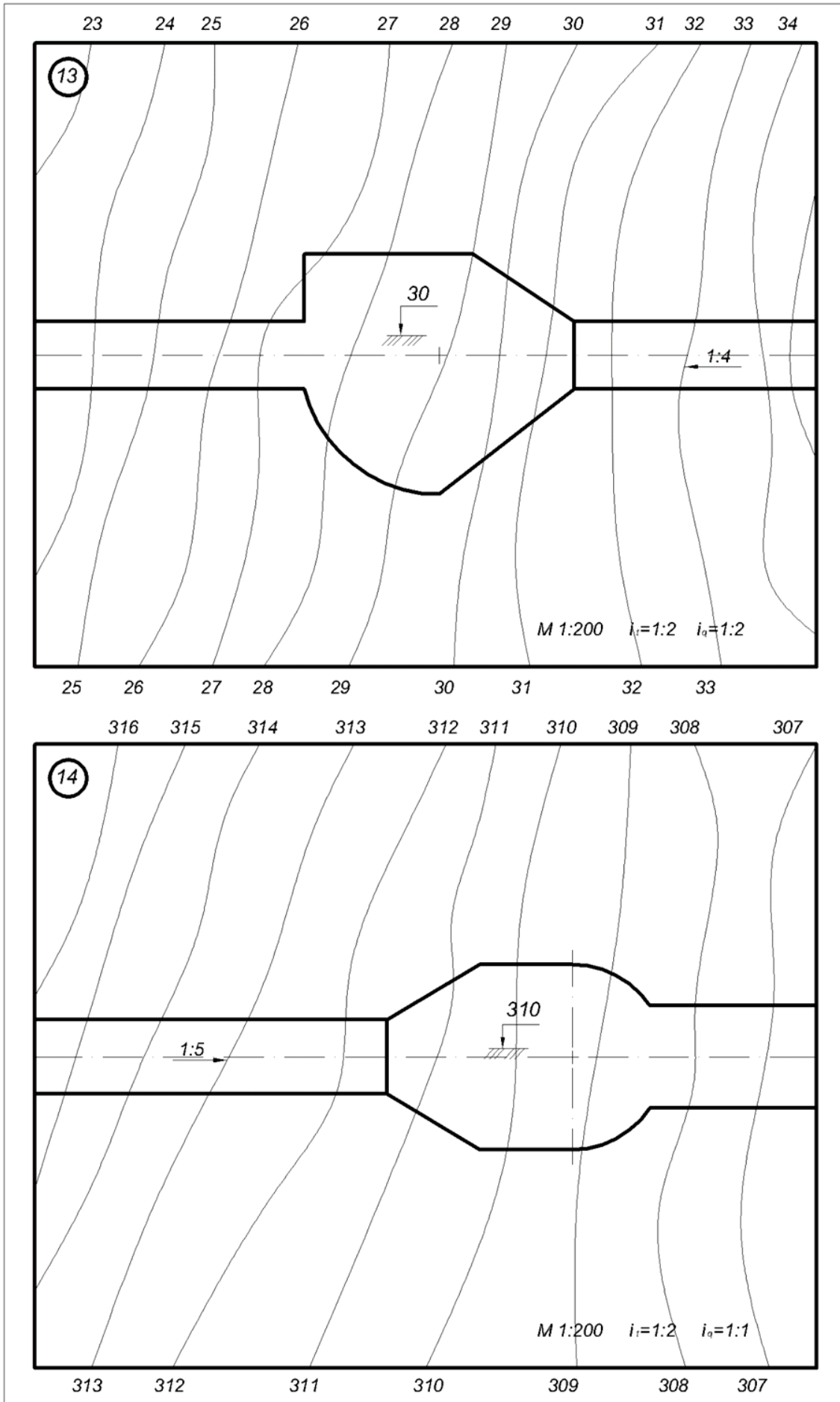

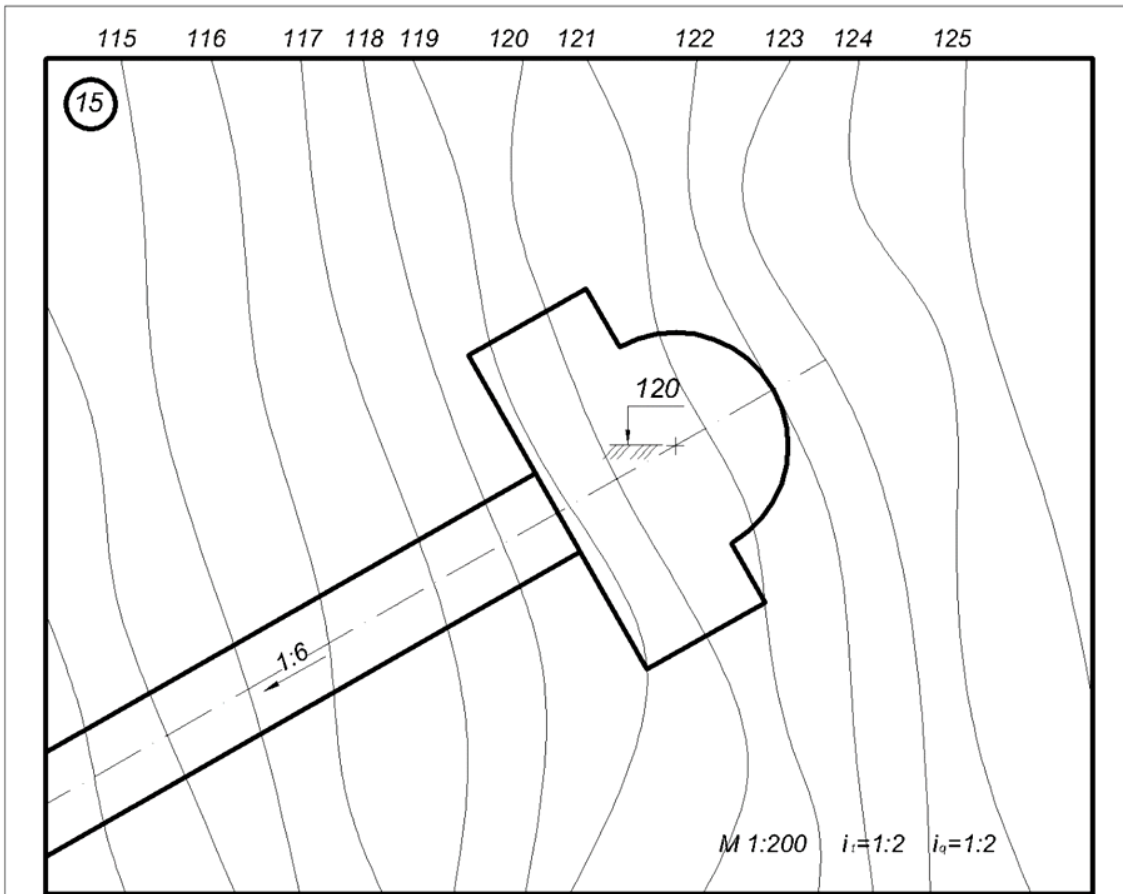

113 114 115 116 117 118 119 120 121 122 123 124
72 71 70 69 68 67 66 65 64 63 62 61

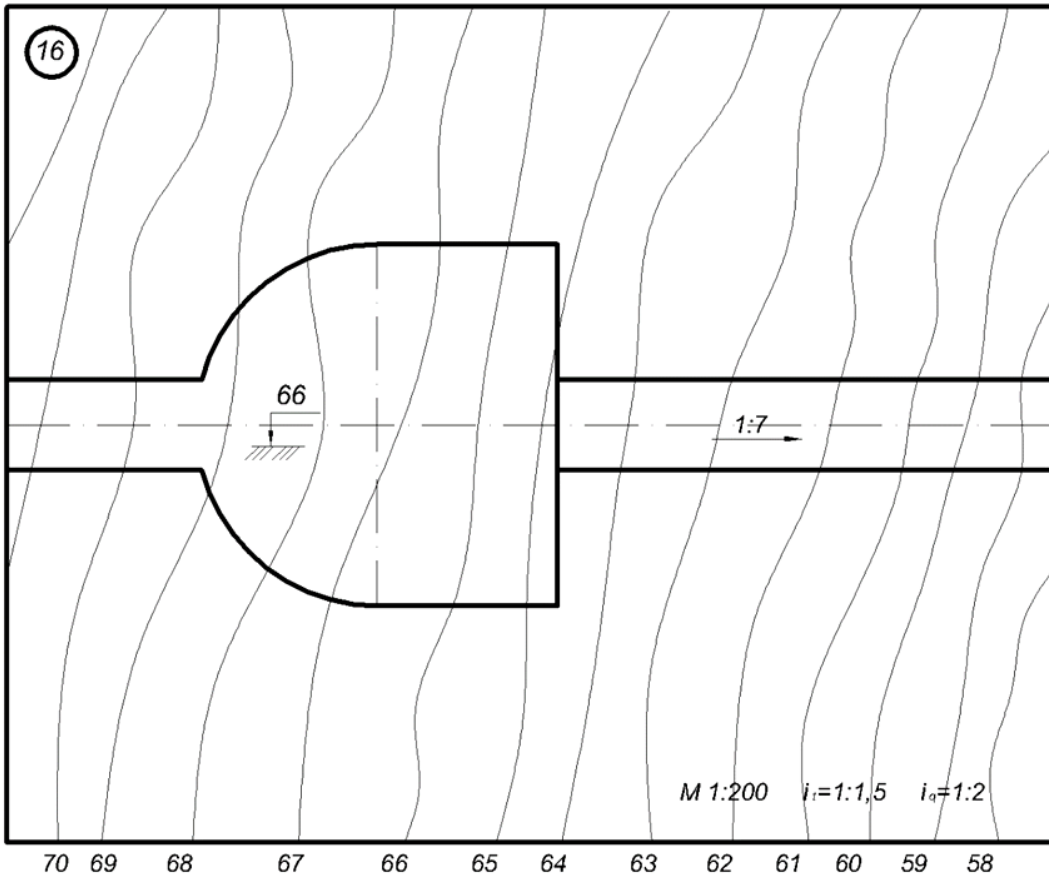

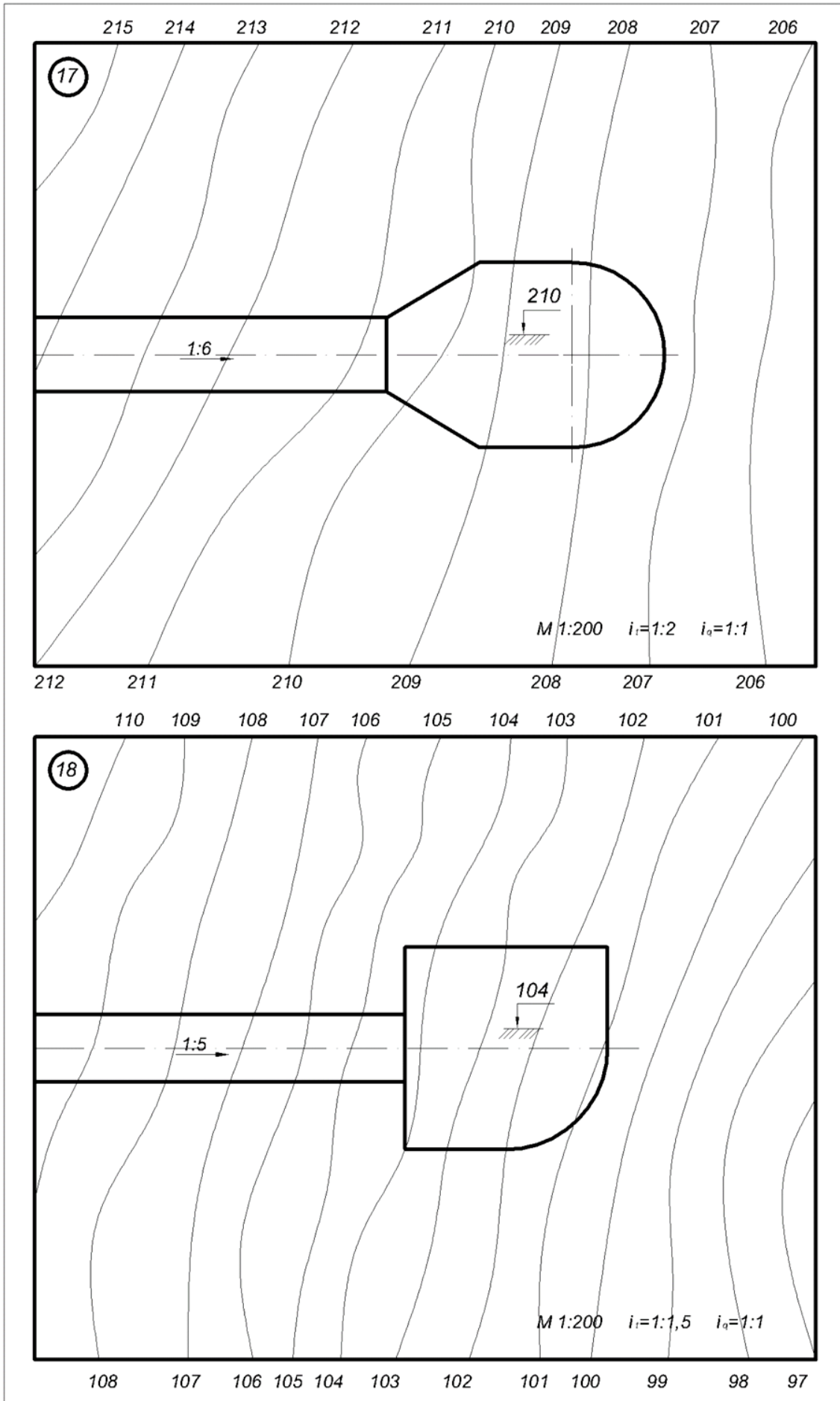

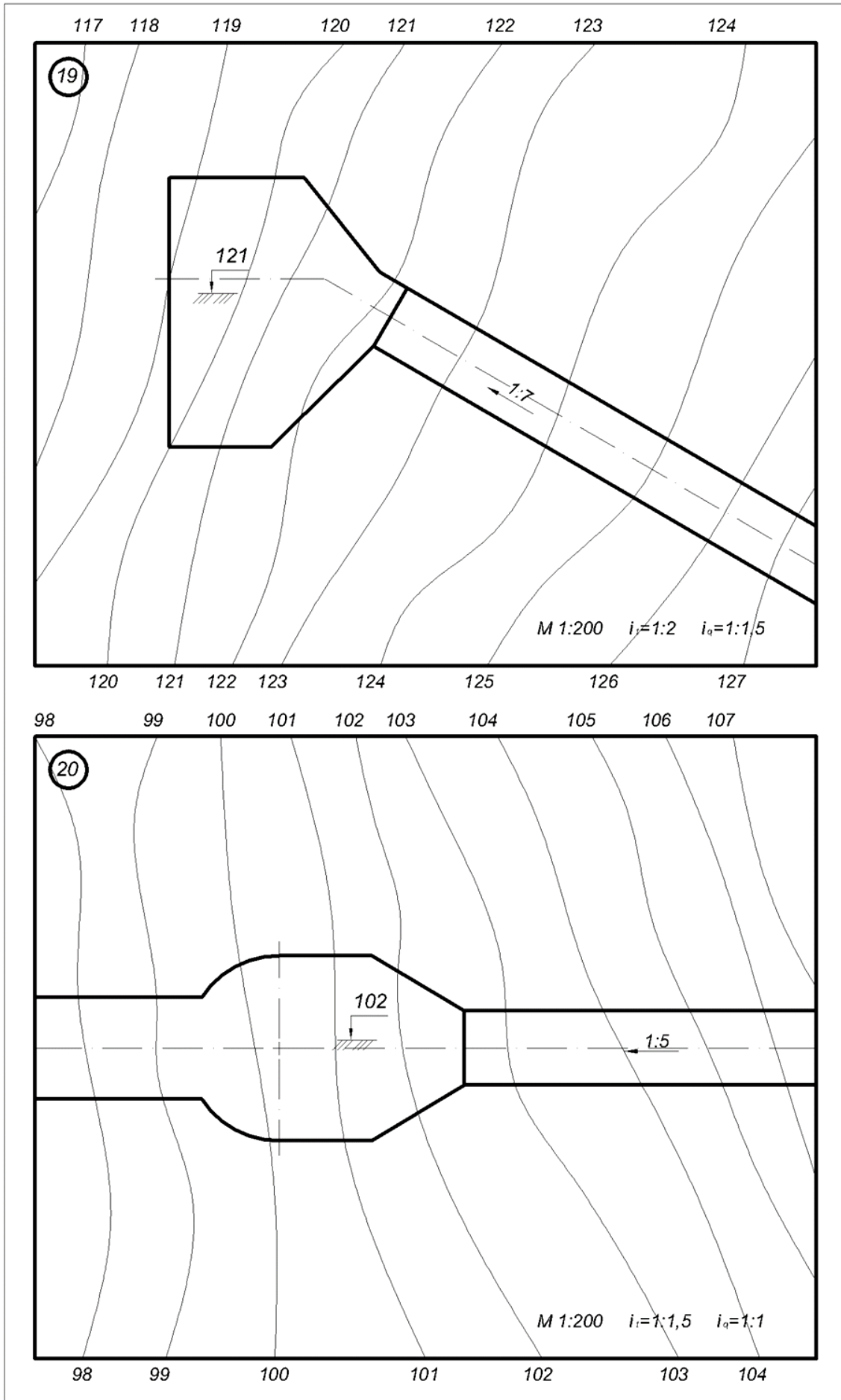

3-grafik ishlar varianti

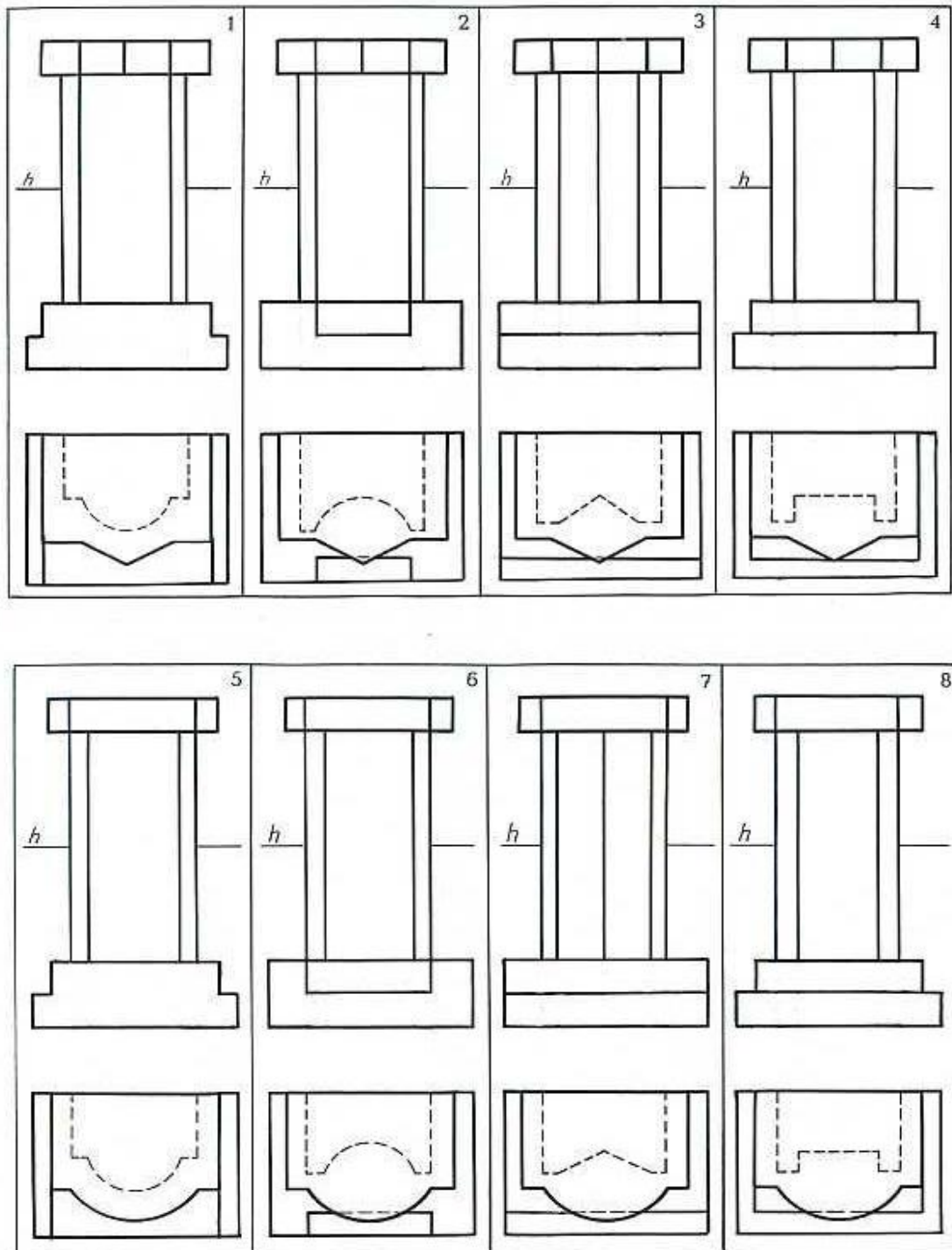

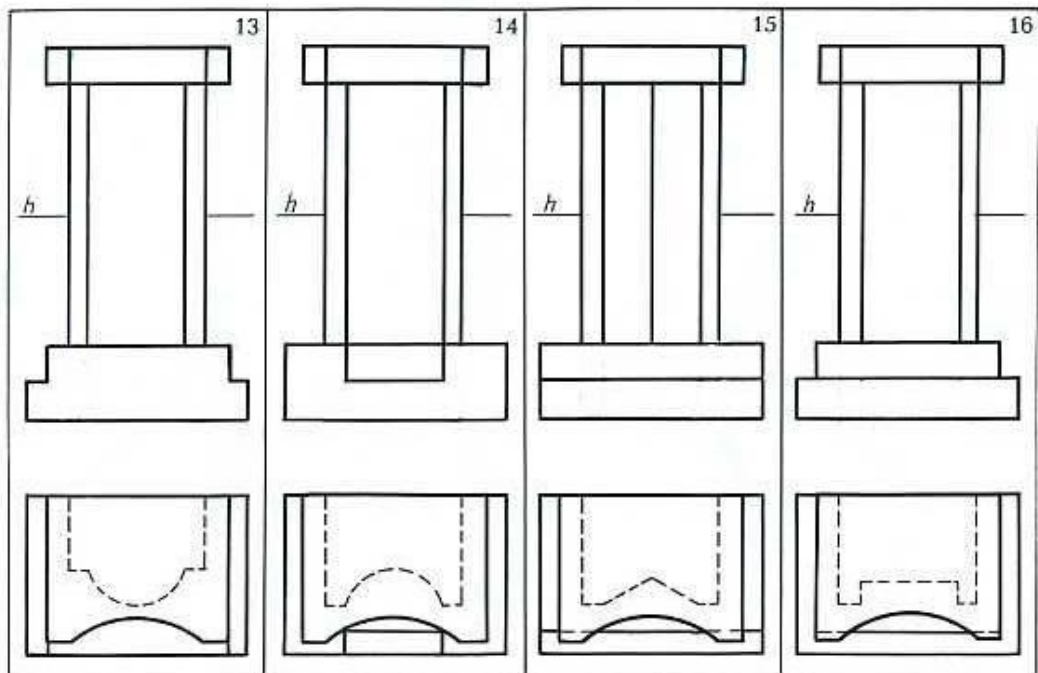
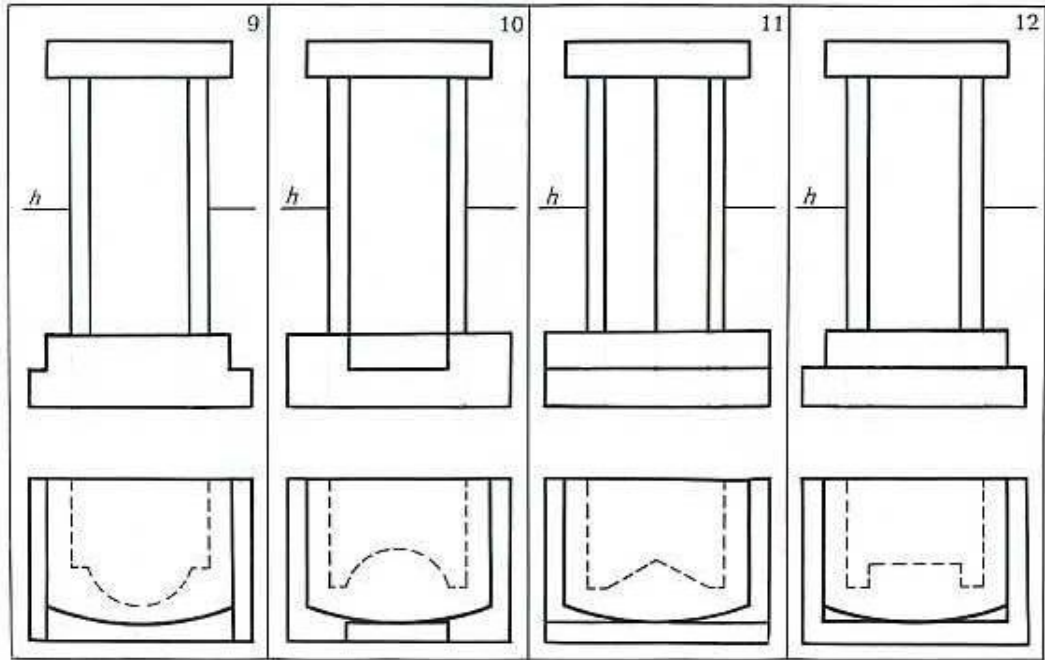

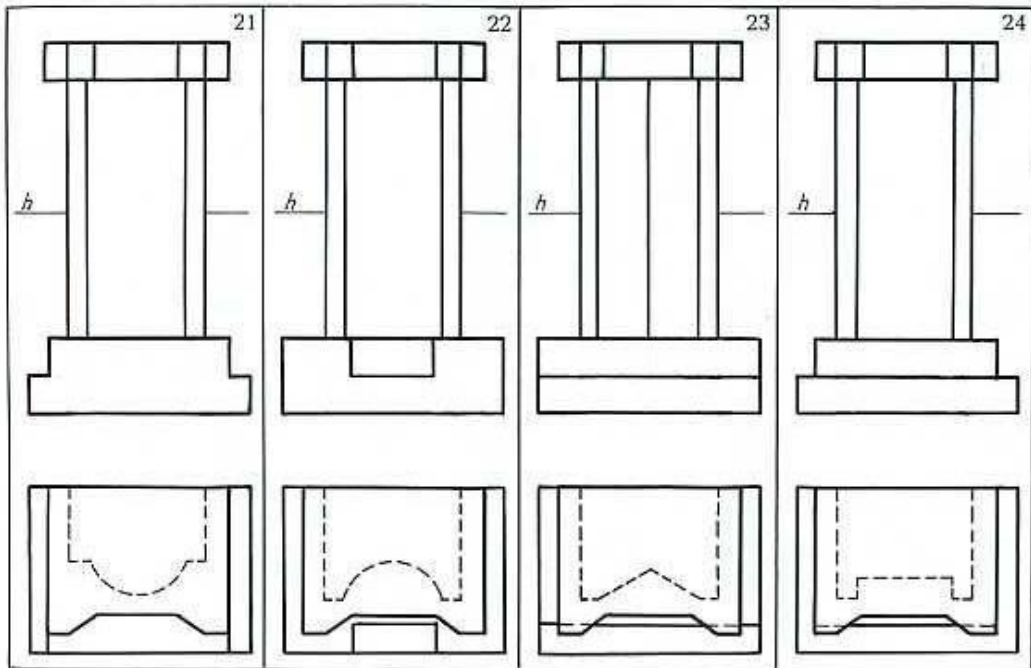
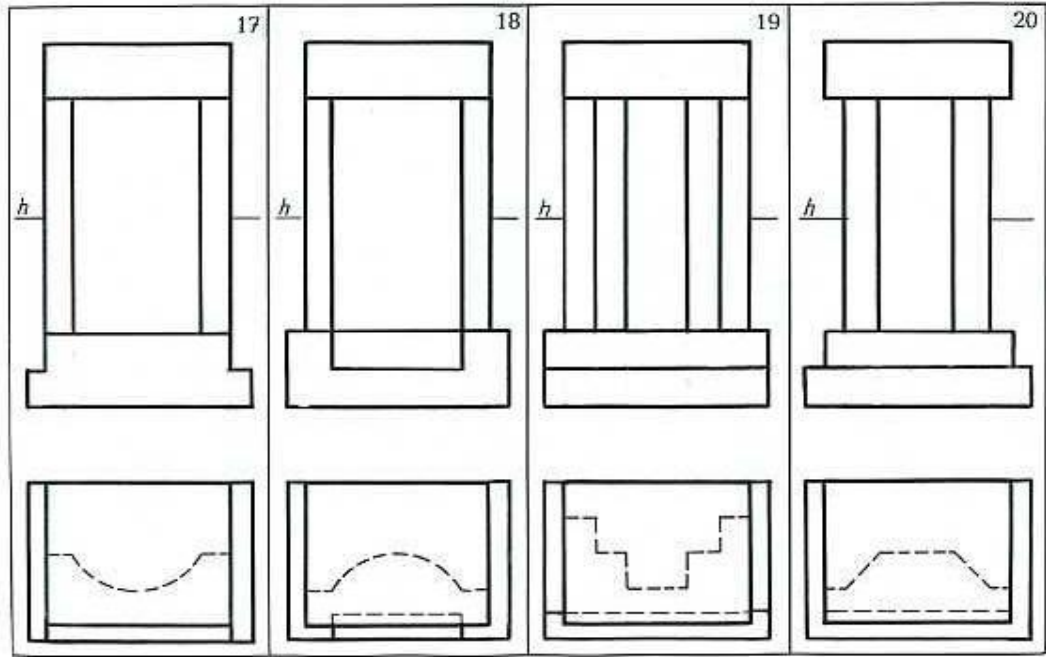

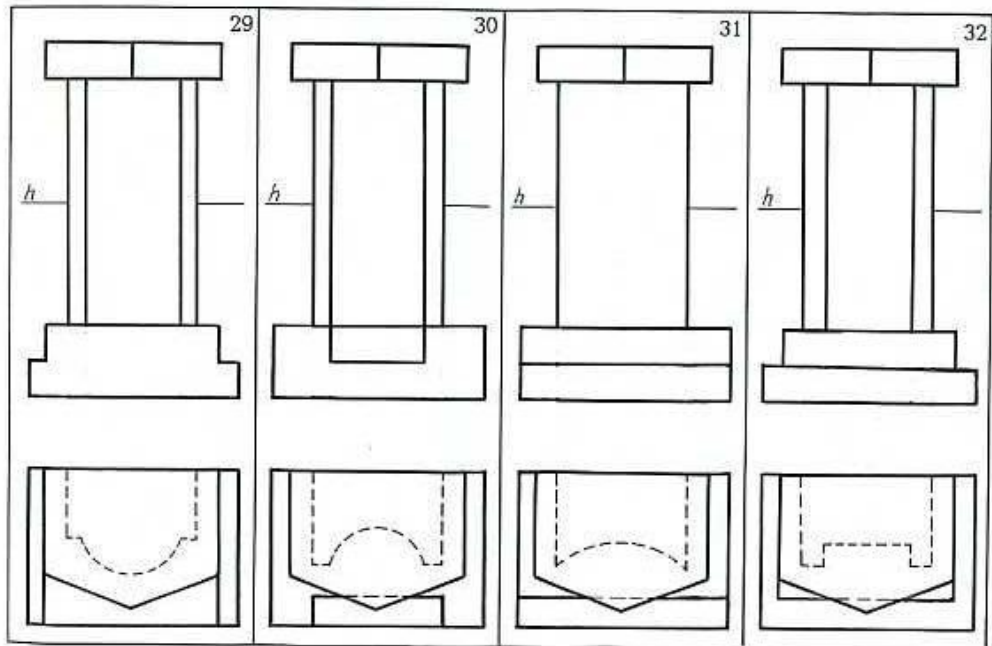
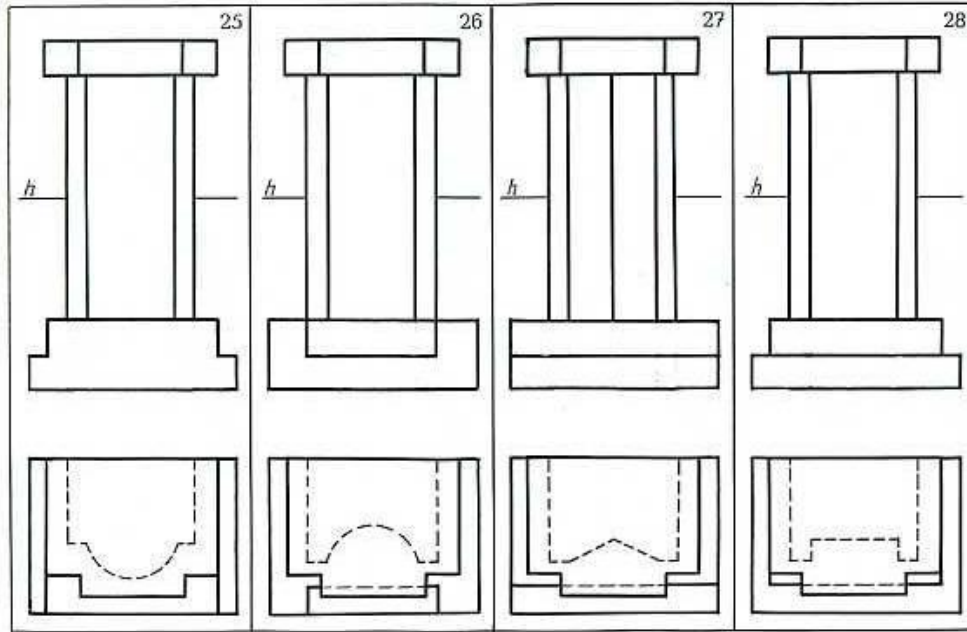

4-Grafik ish variantlari

1-variant

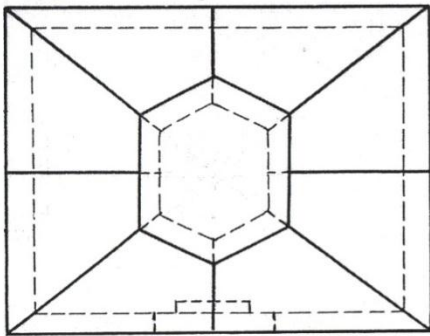
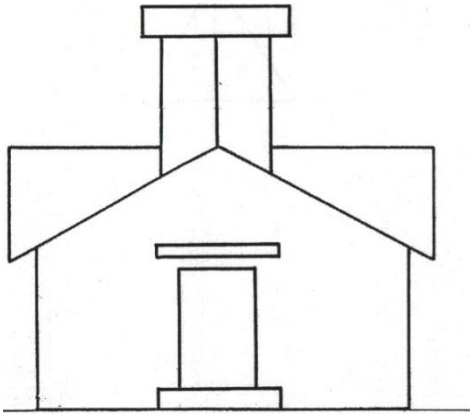

2-variant

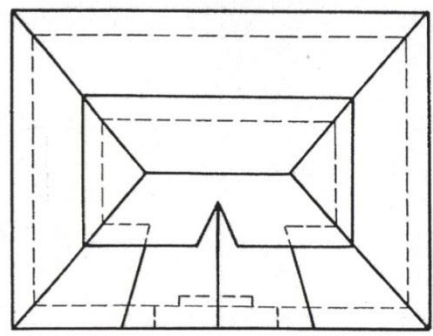
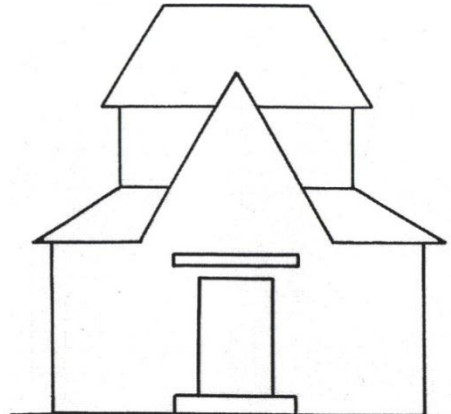

3-variant

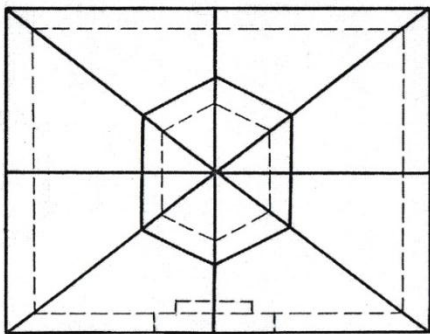
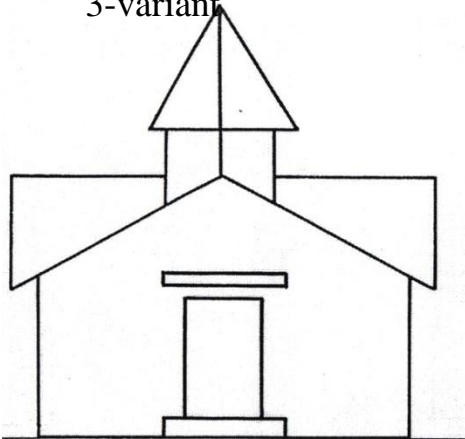

4-variant

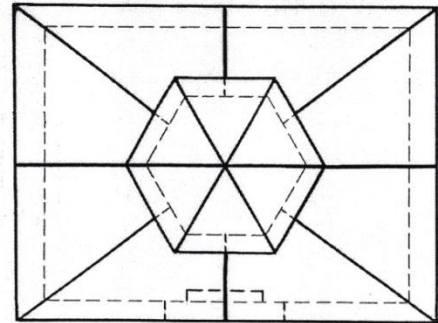
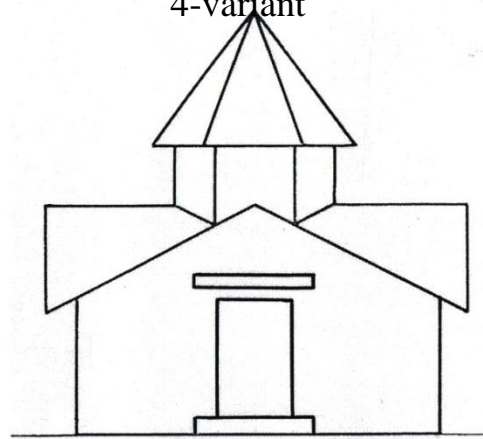

5-variant

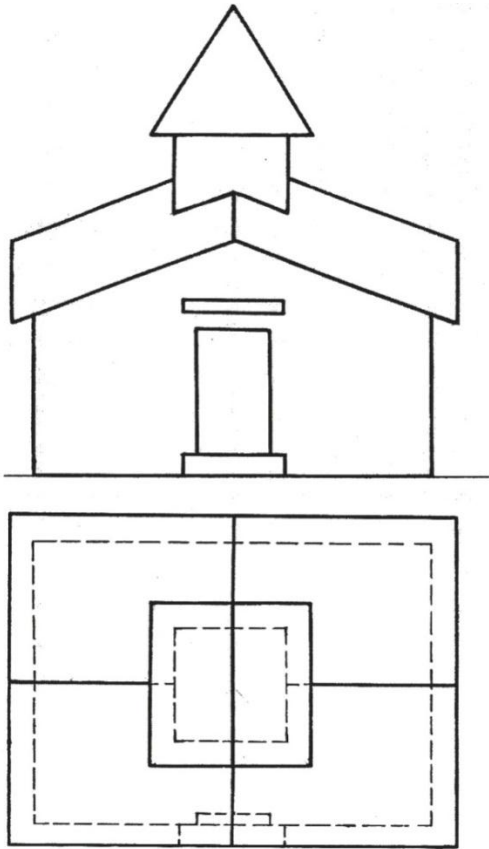

6-variant

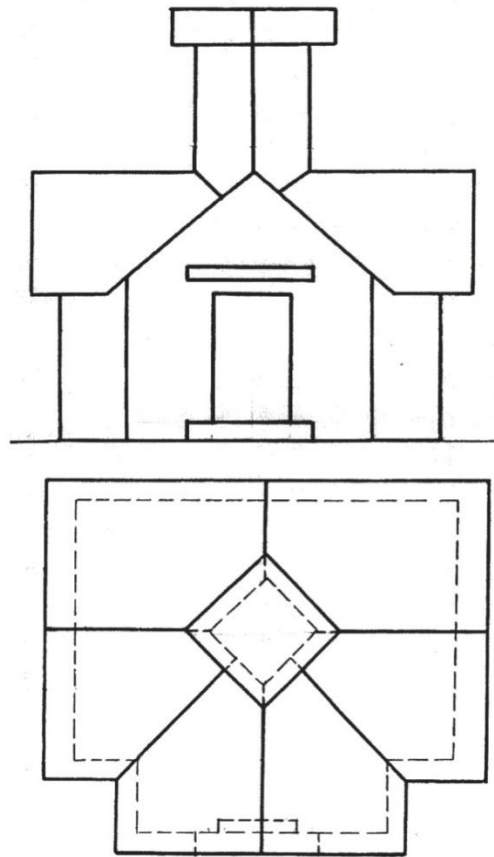

7-variant

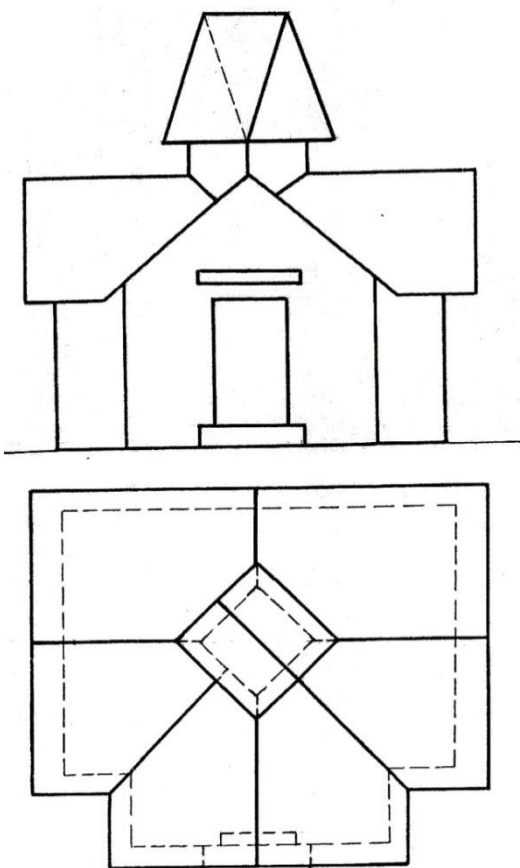

8-variant

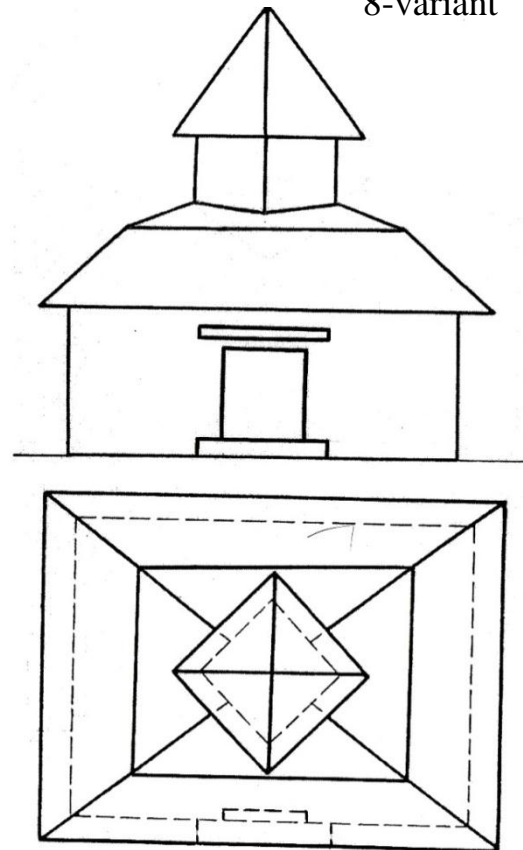

9-variant

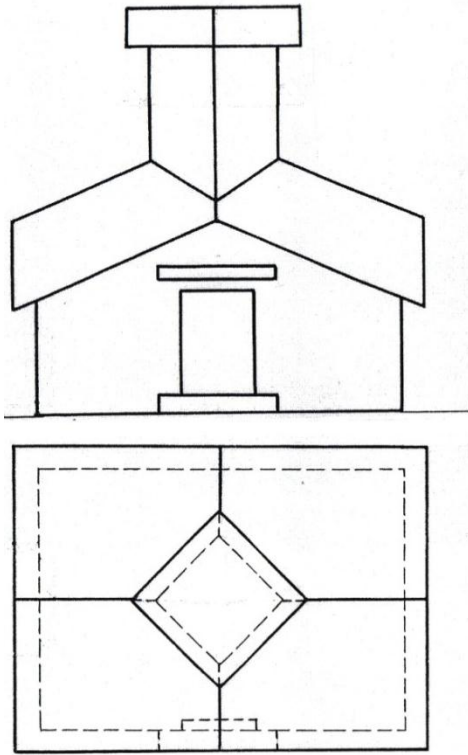

10-variant

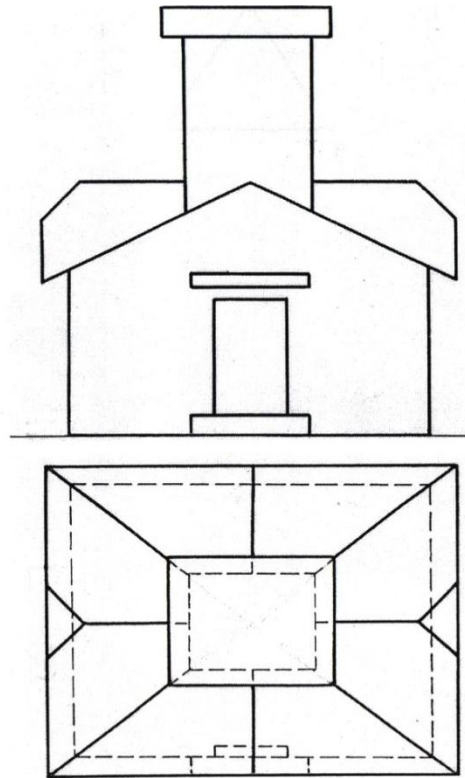

11-variant

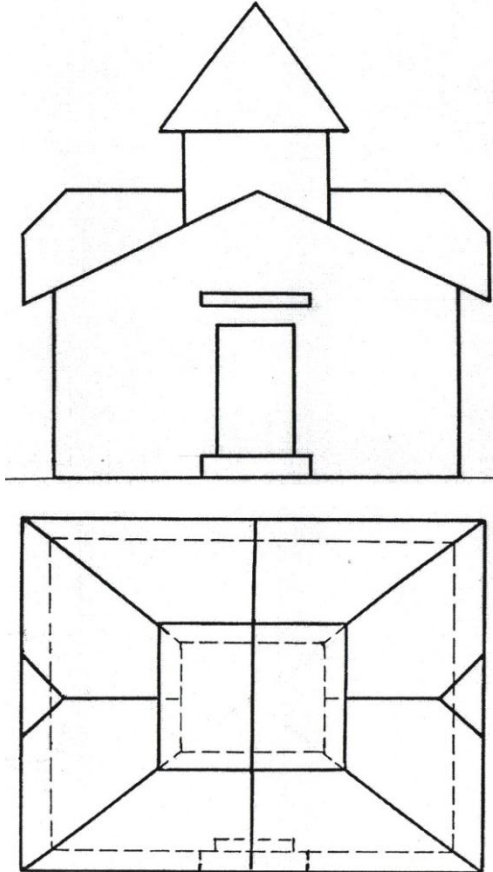

12-variant

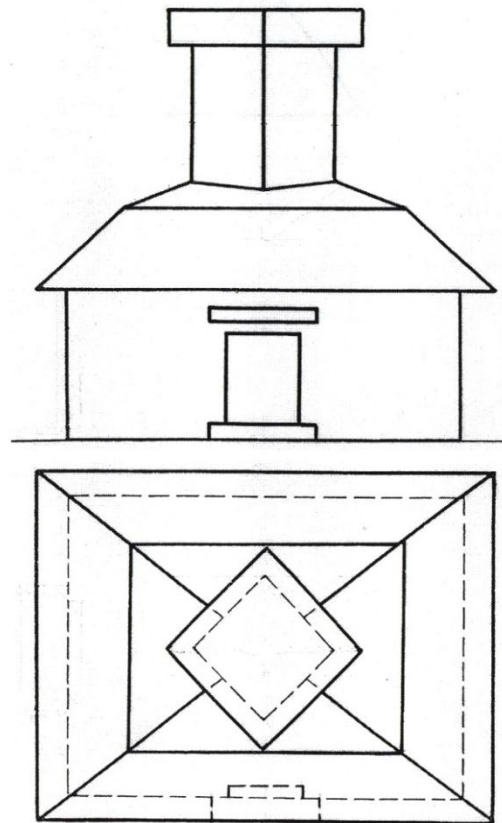

13-variant

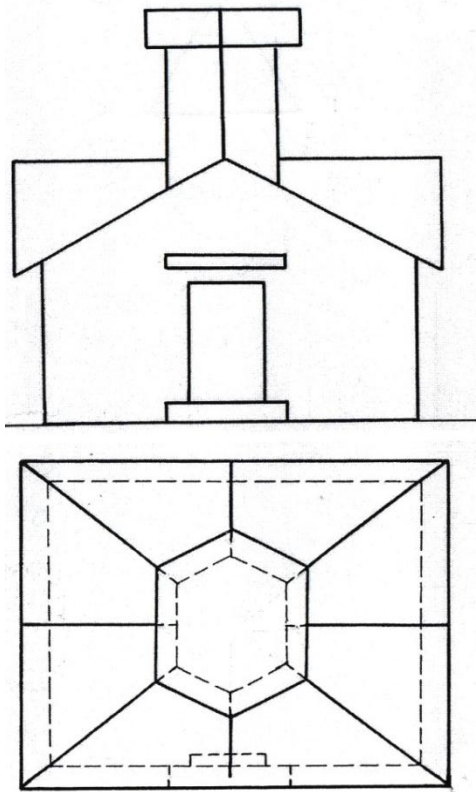

14-variant

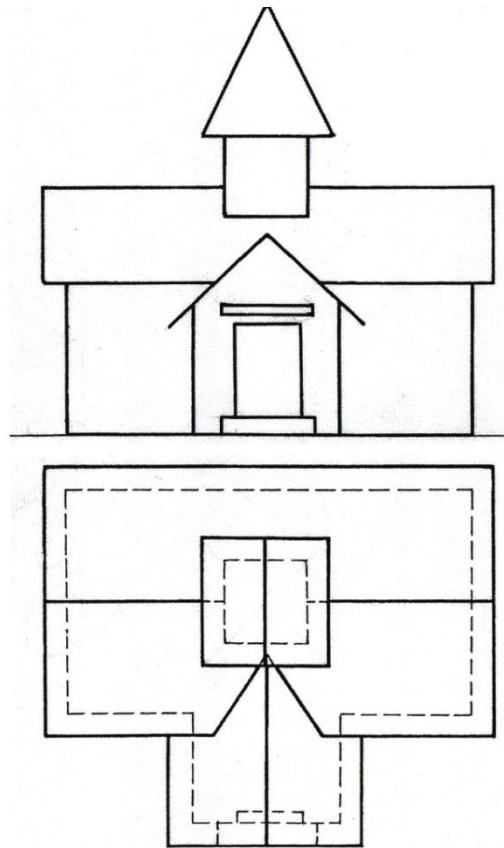

15-variant

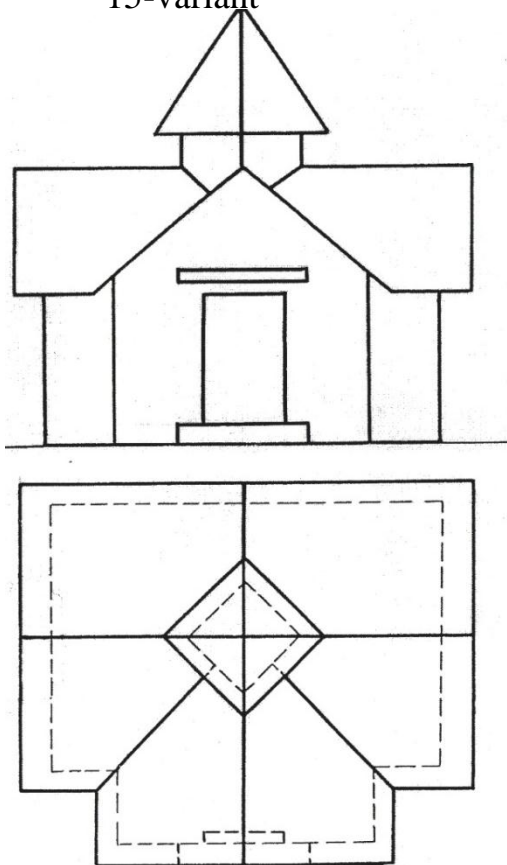

16-variant

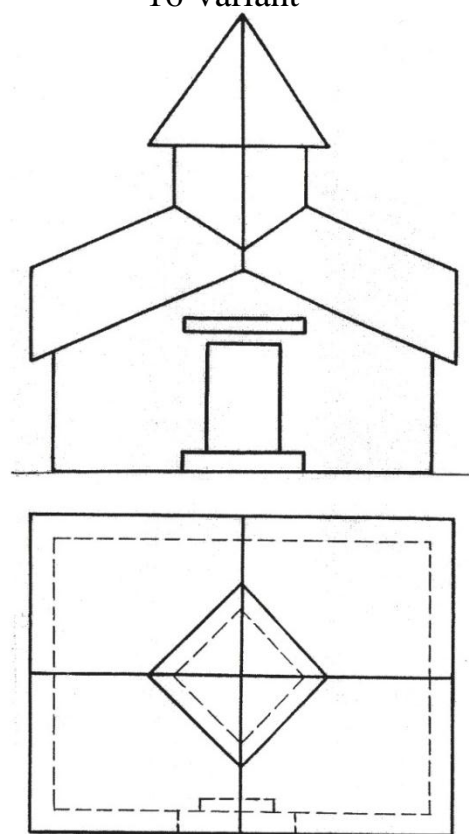

17-variant

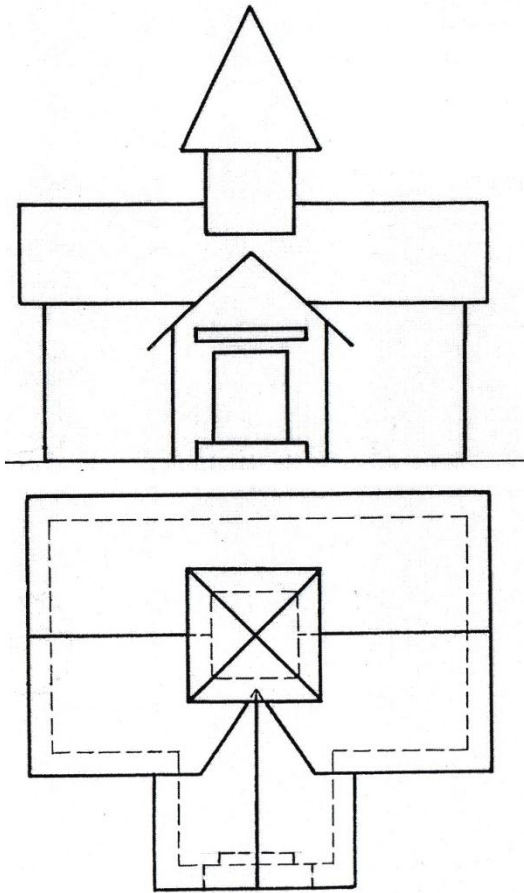

18-variant

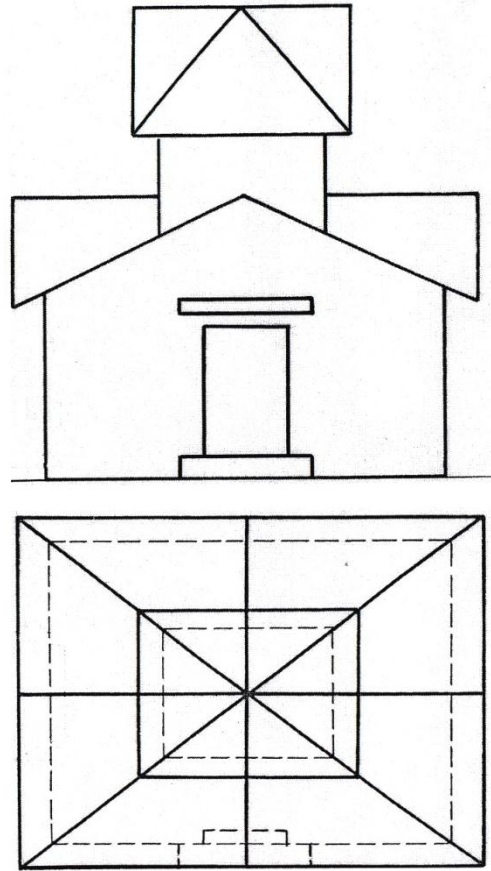

19-variant

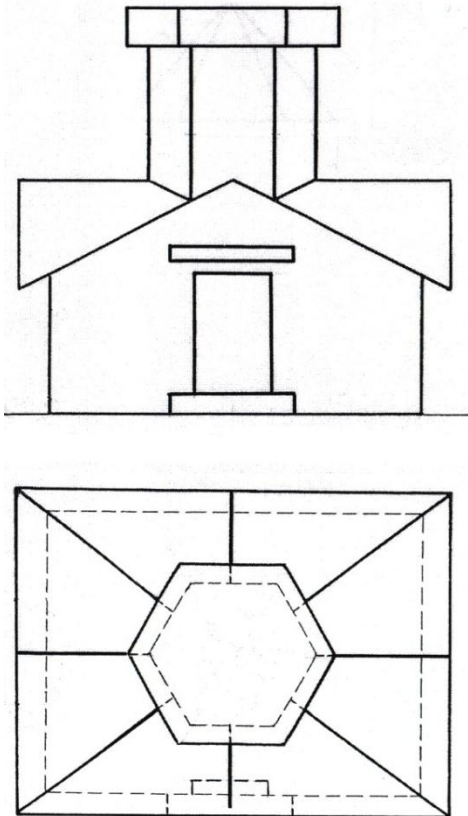

20-variant

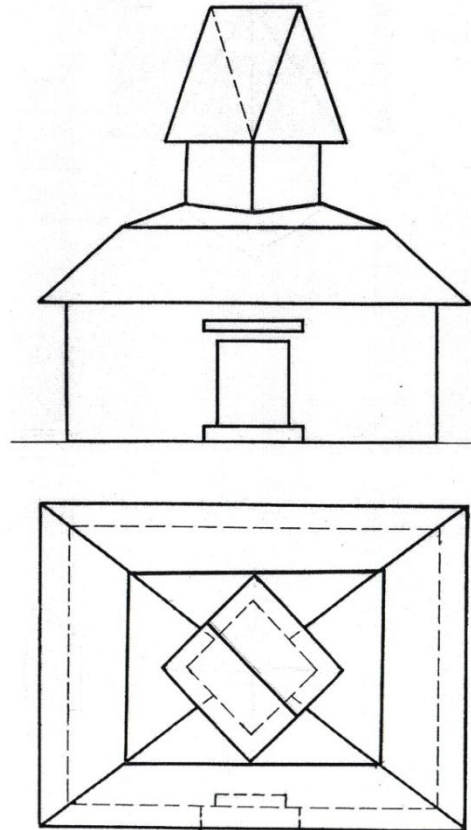

21-variant

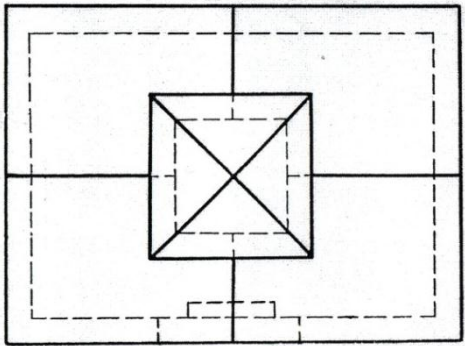
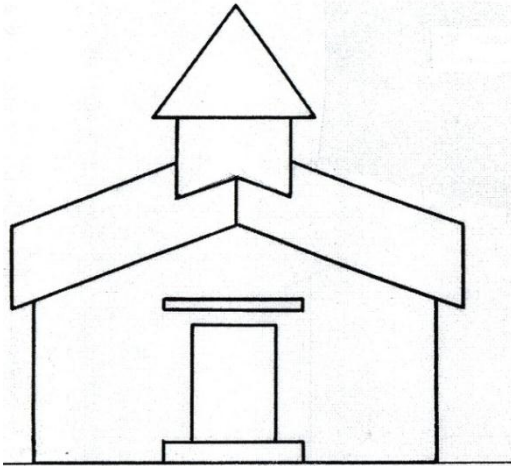

22-variant

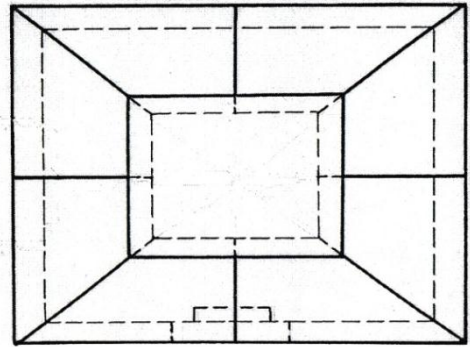
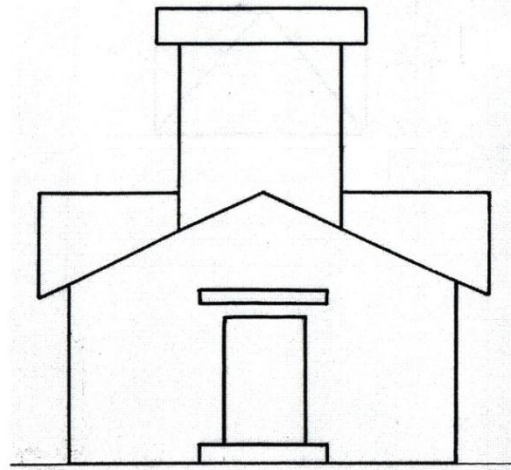

23-variant

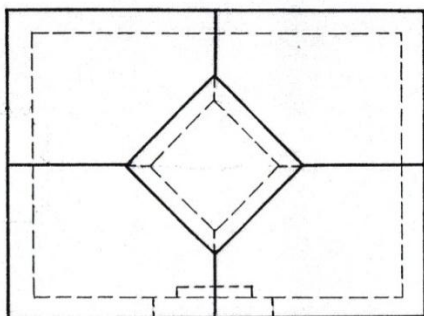
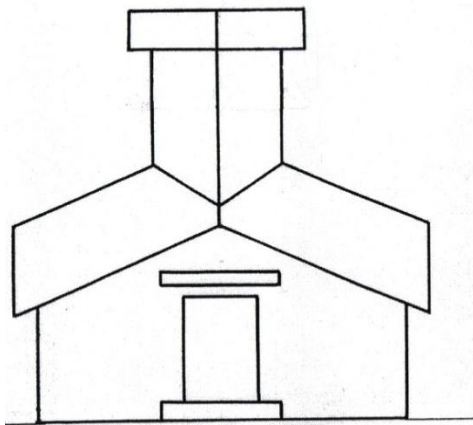

24-variant

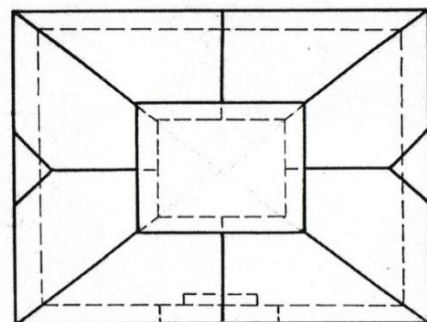
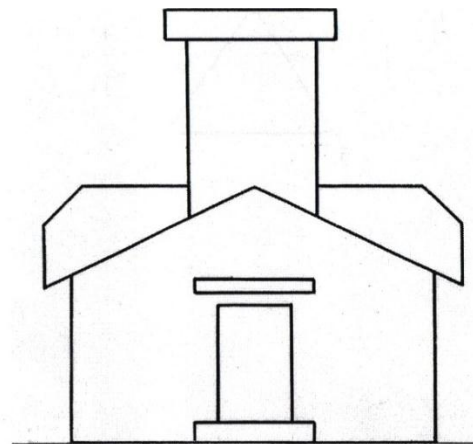

ADABIYOTLAR

1. B.V.Budasov, V.P.Kaminskiy. Stroitelnoe cherchenie. M: Stroyizdat, 1990.
2. A.Umronxo'jaev., Sh. Jumanov., A. Norqulov. Mashinasozlik va qurilish chizmachiligi.Toshkent-2005yil.
3. J. Yodgorov va boshqalar. Chizmachilik. Toshkent-1992yil.
4. P.O. Odilov va boshqalar. Chizmachilik. Toshkent- 2000.
5. A. Abduraxmonov. Chizmachilikdan ma'lumotnoma. Toshkent- 2006.
6. P.Adilov, R.Ismatullayev va boshqalar. Chizmachilik (qurilish chizmachiligi). Toshkent- 2013.
7. Kaminskiy V. P. Stroitelnoe cherchenie : uchebnik dlya vuzov /V. P. Kaminskiy, O. V. Georgievskiy, B. V. Budasov. - M. : OOO Izdatelstvo «Arxitektura - S», 2004 - 456 s.
8. Georgievskiy O. V. Pravila vypolneniya arxitekturno-stroitelnykh chertejey : spravochnoe posobie / O. V. Georgievskiy - M.: AST, Astrel, 2005. - 104 s.
9. YeSKD GOST 2. 301-68 - 2.307-68. Obshchie pravila vypolneniya chertejey. - M.: IPK Izdatelstvo standartov, 2001. - 159 s.

MUNDARIJA		
1	Kirish.....	3
2	Sirtqi ta'lim dasturi.....	5
3	Grafik ishlarga oid ko'rsatmalar va numunalar.....	11
4	Grafik ishlarga oid ko'rsatmalar va numunalar.....	16
5	Grafik ishlar uchun variantlar.....	38
6	Grafik ishlar uchun variantlar.....	78
7	Adabiyotlar.....	102